

---

# TECHNICAL MANUAL

## UNIT MAINTENANCE MANUAL

(INCLUDING REPAIR PARTS AND SPECIAL TOOLS LIST)

### FOR

## ANCILLARY EQUIPMENT FOR

## LOW VELOCITY AIR DROP SYSTEM (LVADS)

Line, Multi-Loop (Extraction Lines, Deployment Lines, Bag Clustering Lines, Riser Extension, Suspension Slings): NSNs 1670-01-062-6301; 1670-01-062-6306; 1670-01-062-6304; 1670-01-062-6305; 1670-01-062-6311; 1670-01-063-7760; 1670-01-062-6310; 1670-01-062-6303; 1670-01-062-6307; 1670-01-062-6312 1670-01-063-7761; 1670-01-062-6308; 1670-01-062-6302; 1670-01-064-4453; 1670-01-107-7651 1670-01-062-6309; 1670-01-064-4451; 1670-01-064-4452; 1670-01-107-7652; Coupling, Extraction Force Transfer: NSNs 1670-00-434-5783; 1670-00-434-5785; 1670-00-434-5787; 1670-00-434-5782; 1670-01-326-7309; Release, Cargo Parachute, M-1: NSN 1670-01-097-8816; Release, Cargo Parachute, M-2: NSN 1670-01-097-8817; Link Assembly, Single Suspension, Type IV: NSN 1670-00-783-5988; Assembly, Heavy Duty: NSNs Link, 4-Point 1670-00-006-2752; Cover, Link, Type IV 1670-00-360-0329; Clevis, Aerial Delivery: NSNs 4030-00-360-0304; 4030-00-678-8562; 4030-00-090-5354; 4030-00-432-2516; Cover, Clevis: NSN 1670-00-360-0328; Strap, Parachute Release, Single Knife: NSN 1670-01-207-7223; Strap, Parachute Release, Multi-Knife: NSN 4340-00-040-8219 ; Link Assembly, Coupling, 3-Point: NSN 1670-01-307-0155; Bracket, Suspension: NSN 1670-01-207-7223; Bracket, Suspension: NSN 1670-00-078-4319; Plate, Suspension: NSN 1670-01-141-1522; Tie-down, Cargo, 10K: NSN 1670-00-937-0271; Tie-down, Cargo, Quick-Release: NSN 1670-01-333-6082; Tie-down, Cargo, Aircraft: NSN 1670-00-545-9063; Drive Off Aid, Type IV: NSN 1670-01-344-0825; Link, 2-Point, 3 ¾-IN.: NSN 1670-01-493-6418; Link, 2-Point, 5 ½-IN.: NSN 1670-01-493-6420; Break Away Static Line, Main: NSN 1670-01-487-5461; Jettison System, Parachute, Extraction: NSN 1670-01-475-1990



**DISTRIBUTION STATEMENT A:** Approved for public release; distribution is unlimited.  
\*This manual supercedes TM 10-1670-296-20&P, dated 15 September 1995



## WARNING SUMMARY

**This warning summary contains general safety warnings and hazardous material warnings that must be understood and applied during operation and maintenance of this equipment. Failure to observe these precautions could result in serious injury or death to personnel.**

---

### WARNING

Personnel performing instructions involving operations, procedures, and practices that are included or implied in this technical manual will observe the following instructions. Disregard of these instructions can result in serious injury or death.

---

### WARNING

#### FIRST AID

For artificial respiration, refer to FM 4-25.11.

---

### WARNING

The squib has a 5-year shelf life assuming it remains in the approved packaging. Once brought into the service, its storage life is 1 year. Failure to follow storage conditions can result in injury to personnel.

---

### WARNING

Squib must be installed with squib cable and safety cap installed. **DO NOT SEPARATE SQUIB CABLE WITH SAFETY CAP FROM SQUIB.** Failure to follow precautions can result in injury to personnel.

**WARNING**

After the squib has been installed in the EPJD, handle EPJD from the bottom only. Failure to do so can result in injury to personnel.

**WARNING**

The squib is a pyrotechnic device. When not installed in aircraft, and all cabling and equipment is not installed, then squib cable safety cap must be installed on squib cable. Use care when handling the squib to prevent accidental firing of the device. Avoid dropping or jarring the squib and avoid static electricity. Failure to follow precautions can result in injury to personnel.

CHANGE  
NO.1

HEADQUARTERS  
DEPARTMENTS OF THE ARMY AND THE AIR FORCE  
WASHINGTON, D.C., 31 MARCH 2006

## TECHNICAL MANUAL

### UNIT MAINTENANCE MANUAL (INCLUDING REPAIR PARTS AND SPECIAL TOOLS LIST) FOR ANCILLARY EQUIPMENT FOR LOW VELOCITY AIR DROP SYSTEM (LVADS)

LINE, MULTI-LOOP (EXTRACTION LINES, DEPLOYMENT LINES, BAG CLUSTERING LINES, RISER EXTENSION, SUSPENSION SLINGS): NSNS 1670-01-062-6301; 1670-01-062-6306; 1670-01-062-6304; 1670-01-062-6305; 1670-01-062-6311; 1670-01-063-7760; 1670-01-062-6310; 1670-01-062-6303; 1670-01-062-6307; 1670-01-062-6312 1670-01-063-7761; 1670-01-062-6308; 1670-01-062-6302; 1670-01-064-4453; 1670-01-107-7651 1670-01-062-6309; 1670-01-064-4451; 1670-01-064-4452; 1670-01-107-7652; COUPLING, EXTRACTION FORCE TRANSFER: NSNS 1670-00-434-5783; 1670-00-434-5785; 1670-00-434-5787; 1670-00-434-5782; 1670-01-326-7309; RELEASE, CARGO PARACHUTE, M-1: NSN 1670-01-097-8816; RELEASE, CARGO PARACHUTE, M-2: NSN 1670-01-097-8817; LINK ASSEMBLY, SINGLE SUSPENSION, TYPE IV: NSN 1670-00-783-5988; ASSEMBLY, HEAVY DUTY: NSNS LINK, 4-POINT 1670-00-006-2752; COVER, LINK, TYPE IV 1670-00-360-0329; CLEVIS, AERIAL DELIVERY: NSNS 4030-00-360-0304; 4030-00-678-8562; 4030-00-090-5354; 4030-00-432-2516; COVER, CLEVIS: NSN 1670-00-360-0328; STRAP, PARACHUTE RELEASE, SINGLE KNIFE: NSN 1670-01-207-7223; STRAP, PARACHUTE RELEASE, MULTI-KNIFE: NSN 4340-00-040-8219 ; LINK ASSEMBLY, COUPLING, 3-POINT: NSN 1670-01-307-0155; BRACKET, SUSPENSION: NSN 1670-01-207-7223; BRACKET, SUSPENSION: NSN 1670-00-078-4319; PLATE, SUSPENSION: NSN 1670-01-141-1522; TIE-DOWN, CARGO, 10K: NSN 1670-00-937-0271; TIE-DOWN, CARGO, QUICK-RELEASE: NSN 1670-01-333-6082; TIE-DOWN, CARGO, AIRCRAFT: NSN 1670-00-545-9063; DRIVE OFF AID, TYPE IV: NSN 1670-01-344-0825; LINK, 2-POINT, 3 3/4-IN.: NSN 1670-01-493-6418; LINK, 2-POINT, 5 1/2-IN.: NSN 1670-01-493-6420; BREAK AWAY STATIC LINE, MAIN: NSN 1670-01-487-5461; JETTISON SYSTEM, PARACHUTE, EXTRACTION: NSN 1670-01-475-1990; LINK, PARACHUTE CONNECTOR: NSN 1670-01483-8259

**DISTRIBUTION STATEMENT A.** - Approved for public release; distribution is unlimited.

TM 10-1670-296-20&P, 30 October 2002, is updated as follows:

1. File this sheet in front of the manual for reference.
2. This change implements changes in unit maintenance procedures for the Squib, Squib Cable and EPJD for the Extraction Parachute Jettison System (EPJS) NSN 1670-01-475-1990. The Parachute Connector Link NSN 1670-01483-8259 has also been added.
3. New or updated change information is indicated by a vertical bar in the outer margin of the page.
4. Added illustrations are indicated by a vertical bar adjacent to the figure number. Changed illustrations are indicated by a vertical bar adjacent to the changed material and adjacent to the figure number.
5. Remove old pages and insert new pages as indicated below:

#### **Remove Pages**

a/b  
A/(B Blank)  
i-iv  
Index 1-6  
Sample 2028 Front/Envelope  
2028 Front/Envelope

#### **Insert Pages**

a/b  
A/B  
i-iv  
Index 1-6  
Sample 2028 Front/Back  
2028 Front/Back  
2028 Front/Back  
2028 Front/Back

ARMY TM 10-1670-296-20&P  
AIR FORCE T.O. 13C7-49-2

---

6. Replace the following work packages with their revised version:

<u>Work Package</u>	<u>Work Package</u>	<u>Work Package</u>	<u>Work Package</u>
WP 0002 00	WP 0044 00	WP 0110 00	WP 0123 00
WP 0005 00	WP 0064 00	WP 0115 00	WP 0124 00
WP 0006 00	WP 0099 00	WP 0120 01	

By Order of the Secretaries of the Army and Air Force:  
C1

**PETER J. SCHOOMAKER**  
*General, United States Army*  
*Chief of Staff*

Official:



**JOYCE E. MORROW**  
*Administrative Assistant to the*  
*Secretary of the Army*  
0607514

**JOHN P. JUMPER**  
*General, USAF*  
*Chief of Staff*

**GREGORY S. MARTIN**  
*General, USAF*  
*Commander, AFMC*

**DISTRIBUTION:** To be distributed in accordance with initial distribution number (IDN) 256283 requirements for TM 10-1670-296-20&P.

INSERT LATEST UPDATED PAGES / WORK PACKAGES. DESTROY SUPERSEDED DATA.

**LIST OF EFFECTIVE PAGES/WORK PACKAGES**

**NOTE:** The portion of text affected by the update is indicated by a vertical line in the outer margins of the page. Changes to illustrations are indicated by a vertical bar adjacent to the title. Zero in the "Change No." column indicates an original page or work package.

Dates of issue for the original manual and changed pages/work packages are:

Original 30 October 2002  
 Change 1 31 March 2006

**TOTAL NUMBER OF PAGES FOR FRONT AND REAR MATTER IS 26. THE TOTAL NUMBER OF WORK PACKAGES IS 128, CONSISTING OF THE FOLLOWING:**

Page/WP No.	Change No.	Page/WP No.	Change No.
a – b	1	WP 0035 00 (2 pages)	0
i – iv	1	WP 0036 00 (2 pages)	0
v/(vi Blank)	0	WP 0037 00 (2 pages)	0
Chapter 1 Title Page	0	WP 0038 00 (2 pages)	0
WP 0001 00 (6 pages)	0	WP 0039 00 (2 pages)	0
WP 0002 00 (32 pages)	1	WP 0040 00 (2 pages)	0
Chapter 2 Title Page	0	WP 0041 00 (2 pages)	0
WP 0003 00 (10 pages)	0	WP 0042 00 (2 pages)	0
WP 0004 00 (6 pages)	0	WP 0043 00 (4 pages)	0
WP 0005 00 (30 pages)	1	WP 0044 00 (6 pages)	1
WP 0006 00 (26 pages)	1	WP 0045 00 (2 pages)	0
Chapter 3 Title Page	0	WP 0046 00 (2 pages)	0
WP 0007 00 (4 pages)	0	WP 0047 00 (2 pages)	0
WP 0008 00 (4 Pages)	0	WP 0048 00 (2 pages)	0
WP 0009 00 (2 pages)	0	WP 0049 00 (2 pages)	0
WP 0010 00 (6 pages)	0	WP 0050 00 (2 pages)	0
WP 0011 00 (2 pages)	0	WP 0051 00 (2 pages)	0
WP 0012 00 (6 pages)	0	WP 0052 00 (6 pages)	0
WP 0013 00 (6 pages)	0	WP 0053 00 (2 pages)	0
WP 0014 00 (2 pages)	0	WP 0054 00 (2 pages)	0
WP 0015 00 (2 pages)	0	WP 0055 00 (2 pages)	0
WP 0016 00 (2 pages)	0	WP 0056 00 (2 pages)	0
WP 0017 00 (10 pages)	0	WP 0057 00 (2 pages)	0
WP 0018 00 (2 pages)	0	WP 0058 00 (2 pages)	0
WP 0019 00 (2 pages)	0	WP 0059 00 (2 pages)	0
WP 0020 00 (6 pages)	0	WP 0060 00 (2 pages)	0
WP 0021 00 (2 pages)	0	Chapter 4 Title Page	0
WP 0022 00 (2 pages)	0	WP 0061 00 (2 pages)	0
WP 0023 00 (4 pages)	0	WP 0062 00 (2 pages)	0
WP 0024 00 (2 pages)	0	WP 0063 00 (4 pages)	0
WP 0025 00 (2 pages)	0	WP 0064 00 (12 pages)	1
WP 0026 00 (2 pages)	0	WP 0065 00 (8 pages)	0
WP 0027 00 (2 pages)	0	WP 0066 00 (4 pages)	0
WP 0028 00 (2 pages)	0	WP 0067 00 (4 pages)	0
WP 0029 00 (2 pages)	0	WP 0068 00 (4 pages)	0
WP 0030 00 (2 pages)	0	WP 0069 00 (4 pages)	0
WP 0031 00 (2 pages)	0	WP 0070 00 (4 pages)	0
WP 0032 00 (2 pages)	0	WP 0071 00 (4 pages)	0
WP 0033 00 (2 pages)	0	WP 0072 00 (4 pages)	0
WP 0034 00 (2 pages)	0	WP 0073 00 (4 pages)	0

**TM 10-1670-296-20&P**

**INSERT LATEST UPDATED PAGES / WORK PACKAGES. DESTROY SUPERSEDED DATA.**

<b>Page/WP No.</b>	<b>Change No.</b>	<b>Page/WP No.</b>	<b>Change No.</b>
WP 0074 00 (4 pages)	0	WP 0103 00 (2 pages)	0
WP 0075 00 (4 pages)	0	WP 0104 00 (2 pages)	0
WP 0076 00 (4 pages)	0	WP 0105 00 (2 pages)	0
WP 0077 00 (4 pages)	0	WP 0106 00 (2 pages)	0
WP 0078 00 (4 pages)	0	WP 0107 00 (2 pages)	0
WP 0079 00 (4 pages)	0	WP 0108 00 (2 pages)	0
WP 0080 00 (2 pages)	0	WP 0109 00 (2 pages)	0
WP 0081 00 (4 pages)	0	WP 0110 00 (2 pages)	1
WP 0082 00 (4 pages)	0	WP 0111 00 (2 pages)	0
WP 0083 00 (2 pages)	0	WP 0112 00 (2 pages)	0
WP 0084 00 (4 pages)	0	WP 0113 00 (2 pages)	0
WP 0085 00 (2 pages)	0	WP 0114 00 (2 pages)	0
WP 0086 00 (2 pages)	0	WP 0115 00 (2 pages)	1
WP 0087 00 (2 pages)	0	WP 0116 00 (2 pages)	0
WP 0088 00 (4 pages)	0	WP 0117 00 (2 pages)	0
WP 0089 00 (2 pages)	0	WP 0118 00 (2 pages)	0
WP 0090 00 (2 pages)	0	WP 0119 00 (2 pages)	0
WP 0091 00 (2 pages)	0	WP 0120 00 (2 pages)	0
WP 0092 00 (2 pages)	0	WP 0120 01 (2 pages)	1
WP 0093 00 (2 pages)	0	WP 0121 00 (4 pages)	0
WP 0094 00 (2 pages)	0	WP 0122 00 (2 pages)	0
WP 0095 00 (2 pages)	0	WP 0123 00 (8 pages)	1
WP 0096 00 (4 pages)	0	WP 0124 00 (4 pages)	1
WP 0097 00 (4 pages)	0	WP 0125 00 (4 pages)	0
WP 0098 00 (4 pages)	0	WP 0126 00 (6 pages)	0
WP 0099 00 (4 pages)	1	WP 0127 00 (2 pages)	0
WP 0100 00 (4 pages)	0	Index 1 - Index 6	1
WP 0101 00 (2 pages)	0		
WP 0102 00 (2 pages)	0		



# **TECHNICAL MANUAL**

## **UNIT MAINTENANCE MANUAL (INCLUDING REPAIR PARTS AND SPECIAL TOOLS LIST) FOR**

### **ANCILLARY EQUIPMENT FOR LOW VELOCITY AIR DROP SYSTEMS (LVADS)**

Line, Multi-Loop (Extraction Lines, Deployment Lines, Bag Clustering Lines, Riser Extension, Suspension Slings): NSNs 1670-01-062-6301; 1670-01-062-6306; 1670-01-062-6304; 1670-01-062-6305; 1670-01-062-6311; 1670-01-063-7760; 1670-01-062-6310; 1670-01-062-6303; 1670-01-062-6307; 1670-01-062-6312 1670-01-063-7761; 1670-01-062-6308; 1670-01-062-6302; 1670-01-064-4453; 1670-01-107-7651 1670-01-062-6309; 1670-01-064-4451; 1670-01-064-4452; 1670-01-107-7652; Coupling, Extraction Force Transfer: NSNs 1670-00-434-5783; 1670-00-434-5785; 1670-00-434-5787; 1670-00-434-5782; 1670-01-326-7309; Release, Cargo Parachute, M-1: NSN 1670-01-097-8816; Release, Cargo Parachute, M-2: NSN 1670-01-097-8817; Link Assembly, Single Suspension, Type IV: NSN 1670-00-783-5988; Assembly, Heavy Duty: NSNs Link, 4-Point 1670-00-006-2752; Cover, Link, Type IV 1670-00-360-0329; Clevis, Aerial Delivery: NSNs 4030-00-360-0304; 4030-00-678-8562; 4030-00-090-5354; 4030-00-432-2516; Cover, Clevis: NSN 1670-00-360-0328; Strap, Parachute Release, Single Knife: NSN 1670-01-207-7223; Strap, Parachute Release, Multi-Knife: NSN 4340-00-040-8219 ; Link Assembly, Coupling, 3-Point: NSN 1670-01-307-0155; Bracket, Suspension: NSN 1670-01-207-7223; Bracket, Suspension: NSN 1670-00-078-4319; Plate, Suspension: NSN 1670-01-141-1522; Tie-down, Cargo, 10K: NSN 1670-00-937-0271; Tie-down, Cargo, Quick-Release: NSN 1670-01-333-6082; Tie-down, Cargo, Aircraft: NSN 1670-00-545-9063; Drive Off Aid, Type IV: NSN 1670-01-344-0825; Link, 2-Point, 3 ¾-IN.: NSN 1670-01-493-6418; Link, 2-Point, 5 ½-IN.: NSN 1670-01-493-6420; Break Away Static Line, Main: NSN 1670-01-487-5461; Jettison System, Parachute, Extraction: NSN 1670-01-475-1990; Link, Parachute Connector: NSN 1670-01-483-8259

## **REPORTING ERRORS AND RECOMMENDING IMPROVEMENTS**

### **ARMY**

You can help improve this manual. If you find any mistakes or if you know of a way to improve the procedures, please let us know. Mail your letter, DA Form 2028 (Recommended Changes to Publications and Blank Forms), or DA Form 2028, located in the back of this manual directly to: Commander, US Army Soldier, Biological and Chemical Command, ATTN: AMSSB-RIM-L (N), Kansas St., Natick, MA 01760. You may also submit your recommended changes by E-mail directly to: <amssbriml@natick.army.mil>. A reply will be furnished directly to you. Instructions for sending electronic 2028 may be found at the back of this manual immediately preceding the hard copy 2028.

### **AIR FORCE**

Reports by U.S. Air Force units should be submitted on AFTO Form 22 (Technical Order Publication Improvement Report and Reply) and forwarded to the address prescribed above for the Army. An information copy of the prepared AFTO Form 22 shall be furnished to WP-ALC/TILTA, 420 2<sup>nd</sup> Street, Suite 100, Robins AFB, GA 31098-1640.

**DISTRIBUTION STATEMENT A.** Approved for public release; distribution is unlimited.

\*This manual supercedes TM 10-1670-296-20&P, dated 15 September 1995

# TABLE OF CONTENTS

	WP Sequence No.
<b>WARNING SUMMARY</b>	<b>a</b>
<b>HOW TO USE THIS MANUAL</b>	<b>v</b>
 <b>CHAPTER 1 – INTRODUCTORY INFORMATION</b>	
General Information.....	0001 00
Equipment Description and Data.....	0002 00
<hr/>	
<b>CHAPTER 2 – OPERATOR MAINTENANCE INSTRUCTIONS</b>	
Service Upon Receipt .....	0003 00
Preventive Maintenance Checks and Services (PMCS), Introduction .....	0004 00
Preventive Maintenance Checks and Services (PMCS), Before Procedures .....	0005 00
Preventive Maintenance Checks and Services (PMCS), After Procedures .....	0006 00
<hr/>	
<b>CHAPTER 3 – UNIT MAINTENANCE INSTRUCTIONS</b>	
Inspection .....	0007 00
Cleaning and Drying.....	0008 00
Salt/Fresh-Water Contamination Test.....	0009 00
Sewing Procedures .....	0010 00
Marking, Restencilling, and Repainting .....	0011 00
Multi-Loop.....	0012 00
Extraction Force Transfer Coupling.....	0013 00
EFTC Adapter Link Assembly .....	0014 00
EFTC 3-Point Adapter Link Assembly.....	0015 00
EFTC Connector Latch Assembly .....	0016 00
EFTC Latch Assembly Coupling .....	0017 00
EFTC Cable Assembly .....	0018 00
EFTC Actuator Assembly .....	0019 00
M-1 Cargo Parachute Release.....	0020 00
M-2 Cargo Parachute Release.....	0021 00
Parachute Connector .....	0022 00
Timer Delay Assembly .....	0023 00
Type IV Single Suspension Link Assembly .....	0024 00
Heavy-Duty Link Assembly .....	0025 00
4-Point Link .....	0026 00
Type IV Link Cover.....	0027 00
Aerial Delivery Clevis .....	0028 00
Clevis Cover .....	0029 00
Single Knife Parachute Release Strap.....	0030 00
Multi-Knife Parachute Release Strap .....	0031 00
3-Point Coupling Link Assembly.....	0032 00
M-35 Suspension Bracket .....	0033 00
M-59 Suspension Bracket .....	0034 00

**CHAPTER 3 – UNIT MAINTENANCE INSTRUCTIONS- continued**

Suspension Plate .....	0035 00
10K Cargo Tie-Down .....	0036 00
Quick-Release Cargo Tie-Down.....	0037 00
Type IV Drive-Off Aid .....	0038 00
Aircraft Cargo Tie-Down.....	0039 00
3 ¾-IN., 2-Point Link.....	0040 00
5 ½-IN., 2-Point Link.....	0041 00
Release Away Static Line Assembly.....	0042 00
Extraction Parachute Jettison System (EPJS).....	0043 00
Extraction Parachute Jettison Device (EPJD), Squib, and Squib Cable .....	0044 00
Y-Connector .....	0045 00
Y-Connector Mounting Box (C-130, C-141, C-17, C-5).....	0046 00
Control Box.....	0047 00
Platform Cable (All)/4-Foot Extension Cable (C-5 and C-17 only).....	0048 00
10-Foot Interconnect Cable.....	0049 00
50-Foot Main Cable.....	0050 00
20-Foot Power Cable .....	0051 00
Protective Cover.....	0052 00
Kit Bag.....	0053 00
Y-Connector Mounting Box Tie-Down Bracket (C-5).....	0054 00
20-Foot Power Cable Extension (C-17 only).....	0055 00
1-Foot Power Cable Adapter (C-5 only).....	0056 00
Safety Cap.....	0057 00
Initiator Simulator .....	0058 00
Squib Tester.....	0059 00
28 VDC Power Supply.....	0060 00

**CHAPTER 4 – SUPPORTING INFORMATION**

Preparation For Storage.....	0061 00
Preparation For Shipment .....	0062 00
References.....	0063 00
Maintenance Allocation Chart (MAC).....	0064 00
Repair Parts and Special Tools List (RPSTL), Introduction .....	0065 00
RPSTL Group 01 Multi-Loop Line .....	0066 00
RPSTL Group 02 Extraction Force Transfer Coupling.....	0067 00
RPSTL Group 0201 Extraction Force Transfer Coupling Adapter Link Assembly .....	0068 00
RPSTL Group 0202 Extraction Force Transfer Coupling 3-Point Coupling Link Assembly .....	0069 00
RPSTL Group 0203 Extraction Force Transfer Coupling Latch Assembly Coupling .....	0070 00
RPSTL Group 0204 Connector Latch Assembly.....	0071 00
RPSTL Group 0205 Coupling Cable Assembly.....	0072 00
RPSTL Group 0206 Actuator Assembly.....	0073 00
RPSTL Group 03 M-1 Cargo Parachute Release .....	0074 00
RPSTL Group 0301 Parachute Connector.....	0075 00
RPSTL Group 0302 Timer Delay Assembly.....	0076 00
RPSTL Group 04 M-2 Cargo Parachute Release .....	0077 00
RPSTL Group 0401 Parachute Connector.....	0078 00
RPSTL Group 0402 Timer Delay Assembly.....	0079 00
RPSTL Group 05 Type IV Single Suspension Link Assembly .....	0080 00
RPSTL Group 0501 Heavy-Duty Link Assembly.....	0081 00
RPSTL Group 0502 4-Point Link.....	0082 00

**CHAPTER 4 – SUPPORTING INFORMATION - continued**

RPSTL Group 0503 Type IV Link Cover .....	0083 00
RPSTL Group 0504 Aerial Delivery Clevis.....	0084 00
RPSTL Group 0505 Clevis Cover .....	0085 00
RPSTL Group 0506 Single Knife Parachute Release Strap .....	0086 00
RPSTL Group 0507 Multi-Knife Parachute Release Strap.....	0087 00
RPSTL Group 0508 3-Point Coupling Link Assembly .....	0088 00
RPSTL Group 0509 M-35 Suspension Bracket.....	0089 00
RPSTL Group 0510 M-59 Suspension Bracket.....	0090 00
RPSTL Group 0511 Suspension Plate.....	0091 00
RPSTL Group 0512 10K Cargo Tie-Down .....	0092 00
RPSTL Group 0513 Quick-Release Cargo Tie-Down .....	0093 00
RPSTL Group 0514 Type IV Drive-Off Aid.....	0094 00
RPSTL Group 0515 Aircraft Cargo Tie-Down .....	0095 00
RPSTL Group 0516 3 ¾-IN., 2-Point Link .....	0096 00
RPSTL Group 0517 5 ½-IN., 2-Point Link .....	0097 00
RPSTL Group 0518 Release Away Static Line Assembly .....	0098 00
RPSTL Group 06 Extraction Parachute Jettison System (EPJS).....	0099 00
RPSTL Group 0601 Extraction Parachute Jettison Device (EPJD) .....	0100 00
RPSTL Group 0602 Y-Connector.....	0101 00
RPSTL Group 0603 Y-Connector Mounting Box (C-130, C-141, C-17).....	0102 00
RPSTL Group 0604 Y-Connector Mounting Box (C-5) .....	0103 00
RPSTL Group 0605 Control Box .....	0104 00
RPSTL Group 0606 Squib Assembly .....	0105 00
RPSTL Group 0607 EPJS Squib Cable .....	0106 00
RPSTL Group 0608 10-Foot Platform Cable.....	0107 00
RPSTL Group 0609 10-Foot Interconnect Cable .....	0108 00
RPSTL Group 0610 50-Foot Main Cable .....	0109 00
RPSTL Group 0611 20-Foot Power Cable.....	0110 00
RPSTL Group 0612 Protective Cover .....	0111 00
RPSTL Group 0613 Kit Bag .....	0112 00
RPSTL Group 0614 4-Foot Extension Cable (C-5 and C-17) .....	0113 00
RPSTL Group 0615 Y-Connector Mounting Box Tie-Down Bracket (C-5).....	0114 00
RPSTL Group 0616 20-Foot Power Cable Extension (C-17 only) .....	0115 00
RPSTL Group 0617 1-Foot Power Cable Adapter .....	0116 00
RPSTL Group 0618 Safety Cap .....	0117 00
RPSTL Group 0619 Initiator Simulator.....	0118 00
RPSTL Group 0620 Squib Tester .....	0119 00
RPSTL Group 0621 28 VDC Power Supply .....	0120 00
RPSTL Group 07 Parachute Connector Link.....	0120 01
RPSTL Group 90 Bulk Materials .....	0121 00
RPSTL Group 95 Special Tools List.....	0122 00
National Stock Number (NSN) Index.....	0123 00
Part Number (P/N) Index.....	0124 00
Expendable/Durable Supplies and Materials List.....	0125 00
Illustrated List of Manufactured Items .....	0126 00
Torque Limits.....	0127 00
<b>ALPHABETICAL INDEX .....</b>	<b>INDEX 1</b>

## HOW TO USE THIS MANUAL

In this manual, primary chapters appear in upper case/capital letters; work packages are presented in numeric sequence, e.g., 0001 00; paragraphs within a work package are not numbered and are presented in a titles format. For a first level paragraph, title all upper case/capital letters, e.g., INTRODUCTION, the next subordinate paragraph title will have the first letter of the first word of each principle word all upper case/capital letters, e.g., How to Use This Manual. The location of additional material that must be referenced is clearly marked. Figures supporting maintenance procedures/text are located as close as possible to their references.

**FRONT MATTER.** Front matter consists of front cover, warning summary, title block, table of contents, and how to use this manual page.

**CHAPTER 1 - INTRODUCTION.** Chapter 1 contains general information and equipment description.

**CHAPTER 2 - OPERATOR INSTRUCTIONS.** Chapter 2 contains service upon receipt and Preventive Maintenance Checks and Services (PMCS) information.

**CHAPTER 3 – UNIT MAINTENANCE INSTRUCTIONS.** Chapter 3 contains maintenance procedures authorized at the unit level.

**CHAPTER 4 – SUPPORTING INFORMATION.** Chapter 4 contains references, expendable and durable items list, maintenance allocation char, repair parts and special tools list, national stock number index, part number index, illustrated list of manufactured items, and torque limits.

**REAR MATTER.** Rear matter consists of alphabetical index, DA Form 2028, authentication page, and back cover.

**Manual Organization and Page Numbering System.** The manual is divided into two major chapters that detail the topics mentioned above. Within each chapter are work packages covering a wide range of topics. Each work package is numbered sequentially starting at page 1. The work package has its own page-numbering scheme and is independent of the page numbering used by other work packages. Each page of a work package has a page number of the for XXXX YY-ZZ where XXXX is the work package number (e.g. 0010 00 is work package 10), YY is the revision number for that work package, and ZZ represents the number of the page within that work package. A page number such as 0010 00-1/(2 Blank) means that page 1 contains information but page 2 of that work package has been intentionally left blank.

**Finding Information.** The Table of Contents permits the reader to find information in the manual quickly. The reader should start here first when looking for a specific topic. The Table of Contents lists the topics contained within each chapter and the Work Package Sequence Number where it can be found.

Example: If the reader were looking for instructions on "Disassemble Extraction Force Transfer Coupling", which is a Unit Maintenance topic, the Table of Contents indicates that Unit Maintenance information can be found in Chapter 3. Scanning down the listings for Chapter 2, "Disassemble Extraction Force Transfer Coupling" information can be found in WP 0013 00 (Work Package 13).

An Alphabetical Index can be found at the back of the manual, and lists specific topics with the corresponding work package.



**CHAPTER 1**  
**INTRODUCTORY INFORMATION**  
**FOR**  
**ANCILLARY EQUIPMENT FOR**  
**LOW VELOCITY AIR DROP SYSTEMS (LVADS)**





---

**ANCILLARY EQUIPMENT FOR LOW VELOCITY AIR DROP SYSTEMS (LVADS)  
GENERAL INFORMATION**


---

**SCOPE**

This Technical Manual (TM) provides unit maintenance instructions for ancillary equipment for the Low Velocity Air Drop System (LVADS). Rigger procedures pertaining to items included in this manual are outlined in the FM 4.20 (FM 10-500) Series publications. This manual also provides a Repair Parts and Special Tools List (RPSTL), located in WP 0065 00 through WP 0121 00.

**Part Number and Equipment Name.** Part Nos. 68F217-48, 68F217- 52, 68F217-49, 68F217-53, 68F217-58, 68F217-59, 68F217-50, 68F217-54, 68F217-22, 68F217-55, 68F217-51, 68F217-56, 68F217-57, 68F217-47, 68F217-45, 68F217-30, 68F217-32, 68F217-41, 68F217-33, 68F217-60, 68F217-61 Line, Multi-Loop (Extraction lines, deployment lines, bag clustering lines, riser extension, suspension slings).

<b>Part Number</b>	<b>Name</b>
11-1-2060	Coupling, Extraction Force Transfer
11-1-1487-2	Release, Cargo Parachute, M-1
11-1-565-2	Release, Cargo Parachute, M-2
11-1-3359	Link Assembly, Single Suspension, Type IV
66B1883	Link Assembly, Heavy Duty
65D3820	Link, 4-Point
50C7496	Cover, Link, Type IV
MS70087	Clevis, Aerial Delivery
50C7406	Clover, Clevis
11-1-129	Strap, Parachute Release, Single-Knife
11-1-484	Strap, Parachute Release, Multi-Knife
11-1-1715-2	Link Assembly, Coupling, 3-Point
53C7084-1	Bracket, Suspension
53C7084-2	Bracket, Suspension
11-1-2615	Plate, Suspension
11-1-721	Tie-down, Cargo, 10k
11-1-3922	Tie-down, Cargo, Quick-Release
11-1-3771	Drive Off Aid, Type IV
MIL-T-25959	Tie-down, Cargo, Aircraft
11-1-7026-1	Link, 2 Point, 3 ¾-Inch
11-1-7026-2	Link, 2 Point, 5 ½-Inch
11-1-4180-1	Assembly, Release Away Static Line
811-00429	Jettison System, Extraction Parachute

**Purpose of Equipment.** The LVADS Ancillary Equipment includes miscellaneous canvas, webbing, and metal items necessary for attaching parachutes to airdrop cargo loads. This equipment is used by airborne/rigger qualified personnel. It does not include the parachutes or platforms used in Low Velocity Air Drop.

**MAINTENANCE FORMS, FORMS, RECORDS, AND REPORTS**

Maintenance forms, forms, records, and reports that you are required to use are DA Form 2402 (Exchange Tag), DA Form 5504 (Maintenance Request), and Standard Form (SF) 368 Product Quality Deficiency Report (PQDR). Their use and procedures for filling out these forms are explained in DA PAM 738-750, The Army Maintenance Management System (TAMMS). USAF personnel use DD Form 1575 (Suspended Tag), DD Form 2332, (Materiel Deficiency Exhibit) and the Air Force (AF) electronic version of SF 368, AFTO Form 244 and AFTO 245. Procedures for use and filling out these forms are contained in AF T.O. 00-35D-54, (USAF Deficiency, Reporting and Investigation System), AF T.O. 00-20-5 (Aerospace/Equipment Inspection and Documentation), AF T.O. 00-20-3 (Maintenance Processing of Repairable Property and the Repair Cycle Asset Control System), Air Force Instruction (AFI) 21-115 (Deficiencies Across Component Lines) for reporting deficiencies which cross DOD components lines and Air Force Manual (AFMAN) 23-110, Volume 1, Part 1 (USAF Supply Manual).

**REPORTING EQUIPMENT IMPROVEMENT RECOMMENDATIONS (EIR)**

If the design of your equipment needs improvement, let us know. Send us an EIR. You, the user, are the only one who can tell us what you don't like about your equipment. Let us know why you don't like the design or performance. Put it on an SF 368 PQDR. Mail it to: Commander, U.S. Army Soldier and Biological Chemical Command, ATTN: AMSSB-RIM-E (N), Kansas Street, Natick, MA 01760-5052. Navy-Submit NAVSEA Form 4160/1 (REV 2-99) to Commander, NSDSA Code 5E30, NAVSURFCENDIV, 4363 Missile Way, Port Hueneme, CA 93043-4307. A reply will be furnished directly to you.

**CORROSION PREVENTION AND CONTROL (CPC)**

Corrosion Prevention and Control (CPC) of Army materiel is a continuing concern. It is important that any corrosion problems with this item be reported so that the problem can be corrected and improvements can be made to prevent the problem in future items.

While corrosion is typically associated with rusting of metals, it can also include deterioration of other materials, such as rubber and plastic. Unusual cracking, softening, swelling, or breaking of these materials may be a corrosion problem.

If a corrosion problem is identified, it can be reported using SF 368 PQDR. Use of keywords such as "corrosion", "rust", "deterioration", or "cracking" will ensure the information is identified as a CPC problem.

The form should be submitted to the address specified in DA PAM 738-750, Functional Users Manual for the Army Maintenance Management System (TAMMS).

**DESTRUCTION OF ARMY MATERIEL TO PREVENT ENEMY USE****GENERAL INFORMATION:**

**Objective.** Methods of destruction used to inflict damage on air delivery equipment should make it impossible to restore equipment to a usable condition in a combat zone by either repair or cannibalization.

**Authority.** Destruction of air delivery equipment that is in imminent danger of capture by an enemy is a command decision that must be made by a battalion or higher commander, or the equivalent.

**Implementation plan.** All units, that possess air delivery equipment, should have a plan for the implementation of destruction procedures.

**Training.** All personnel who use or perform such functions as rigging, packing, maintenance, or storage of air delivery equipment should receive thorough training on air delivery equipment destruction procedures and methods. The destruction methods demonstrated during training should be simulated. Upon completion of training, all applicable personnel should be thoroughly familiar with air delivery equipment destruction methods and be capable of performing destruction without immediate reference to any publication.

#### **SPECIFIC METHODS:**

Specific methods of destroying Army materiel to prevent enemy use shall be by mechanical means, fire, or by use of natural surroundings.

**Destruction by Mechanical Means.** Air delivery equipment metal assemblies, parts, and packing aids shall be destroyed using hammers, bolt cutters, files, hacksaws, drills, screwdrivers, crowbars, or other similar devices used to smash, break, bend or cut.

#### **WARNING**

Exercise extreme care when using petroleum products to destroy equipment by fire, as these materials are highly flammable. Improper handling may cause injury to personnel.

**Destruction by Fire.** Items that can be destroyed by fire shall be burned. The destruction of equipment by use of fire is an effective method of destroying low-melting-point metal items (e.g., cutter brackets, threaded portions of nuts and bolts, and clevises). However, mechanical destruction should be completed first, whenever possible, before initiating destruction by fire. When items to be destroyed are made of metal, textile materials (or some comparable low combustible material) should be packed under and around the items, then soaked with a flammable petroleum product and ignited. Proper concentration of equipment, which is suitable for burning, will provide a hotter and more destructive fire.

**Destruction by Use of Natural Surroundings.** Small vital parts of assemblies, which are easily accessible, may be disposed of as follows: Disposal or denial of equipment to an enemy may be accomplished through use of natural surroundings. Accessible vital parts may be removed and scattered through dense foliage, buried in dirt or sand, or thrown into a lake or other body of water. Total submersion of equipment in a body of water will provide water damage as well as concealment. Salt water will inflict extensive damage to air delivery equipment.

#### **PREPARATION FOR STORAGE OR SHIPMENT**

For storage, refer to TM 10-1670-201-23/T.O. 13C-1-41 and WP 0061 00 of this manual; for shipment, refer to WP 0062 00 of this manual.

#### **WARRANTY INFORMATION**

LVADS ancillary equipment contains no warranty provisions.

**NOMENCLATURE CROSS REFERENCE LIST**

<b>Common Name</b>	<b>Official Nomenclature</b>
Arm Clustering Assembly	Link, 4-Point
Crocus Cloth	Cloth, Abrasive, Ferric Oxide and Quartz
Timer and Stem Assembly	Timing Movement, Mechanical

**LIST OF ACRONYMS AND ABBREVIATIONS**

AF	Air Force
AFI	Air Force Instruction
AFMAN	Air Force Manual
AFSC	Air Force Supply Code
AFTO	Air Force Technical Order
AMP	Ampere
AR	Acquisition Request
AVIM	Aviation Intermediate Maintenance
AVUM	Aviation Unit Maintenance
BOI	Basic of Issue
CAGEC	Commercial and Government Entity Code
CM	Centimeter
CPC	Corrosion Prevention and Control
CTA	Common Table of Allowance
DA	Department of the Army
DAPAM	Department of the Army Pamphlet
EFTC	Extraction Force Transfer Coupling
EIR	Equipment Improvement Recommendations
EMP	Electromagnetic Pulse
EPJD	Extraction Parachute Jettison Device
EPJS	Extraction Parachute Jettison System
FM	Field Manual
GPM	Ground Precautionary Message
HCI	Hardness Critical Item
IAW	In Accordance With
IN	Inch
JTA	Joint Table of Allowance
KG	Kilograms
LED	Light Emitting Diode
LVADS	Low Velocity Air Drop System
M	Meters
MAC	Maintenance Allocation Chart
MAM	Maintenance Advisory Message
MOS	Military Occupational Specialty
MTOE	Modified Table of Organization and Equipment
MWO	Modification Work Order
NAVSCA	Naval Sea Systems Command
NIIN	National Item Identification Number
NMP	National Maintenance Point
NSDSA	Naval System Data Support Activity

**LIST OF ACRONYMS AND ABBREVIATIONS -continued**

NSN	National Stock Number
P/N	Part Number
PCB	Printed Circuit Board
PMCS	Preventive Maintenance Checks and Services
PQDR	Product Quality Deficiency Report
QTY	Quantity
RPSTL	Repair Parts and Special Tools List
SF	Standard Form
SMR	Source, Maintenance and Recoverability
SRA	Special Repair Activity
TAMMS	The Army Maintenance Management System
TDA	Table of Distribution and Allowance
TM	Technical Manual
TMDE	Test Measurement and Diagnostic Equipment
TO	Technical Order
TOE	Table of Organizational and Equipment
U/I	Unit of Issue
U/M	Unit of Measure
UOC	Usable on Code
USAF	United States Air Force
VAC	Volts Alternating
VDC	Volts Direct Current
WP	Work Packages

**SAFETY, CARE AND HANDLING**

The following subparagraphs summarize the safety, care, and handling requirements for the parachute assembly.

**Safety.** It is imperative that you observe all safety precautions specified on the warning summary in the front of this manual. You must also observe specific warnings and cautions specified throughout this manual. The warnings are provided to tell you how to protect yourself from serious injury or death.

**Care and Handling.** Every effort shall be made to protect equipment from weather elements, dust, dirt, oil, grease, and acid.

**COMMON TOOLS AND EQUIPMENT**

For authorized common tools and equipment, refer to the Modified Table of Organization and Equipment (MTOE) applicable to your unit.

**SPECIAL TOOLS, TEST MEASUREMENT AND DIAGNOSTIC EQUIPMENT (TMDE), AND SUPPORT EQUIPMENT**

Special Tools, TMDE and support equipment are not required.

**REPAIR PARTS AND SPECIAL TOOLS LIST (RPSTL)**

Repair parts are listed and illustrated in WP 0065 00 – WP 0121 00 of this manual.

**END OF WORK PACKAGE**



**ANCILLARY EQUIPMENT FOR LOW VELOCITY AIR DROP SYSTEMS (LVADS)  
EQUIPMENT DESCRIPTION AND DATA**

**EQUIPMENT CHARACTERISTICS, CAPABILITIES, AND FEATURES**

**Characteristics.** All equipment is lightweight and heavy-duty. Equipment can be combined in multiple configurations for customization.

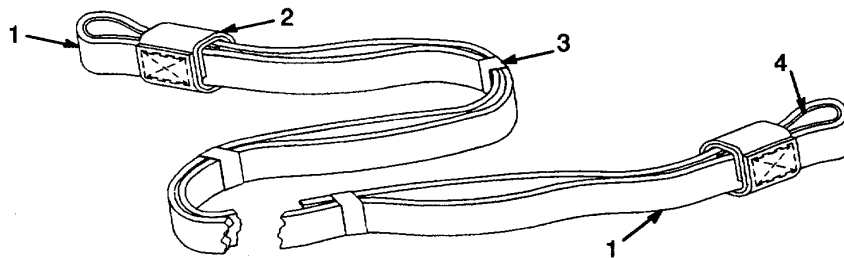
**Capabilities and Features.** Safely drop platform loads without landing aircraft. Drop single platform or multiple platforms.

**LOCATION AND DESCRIPTION OF MAJOR COMPONENTS**

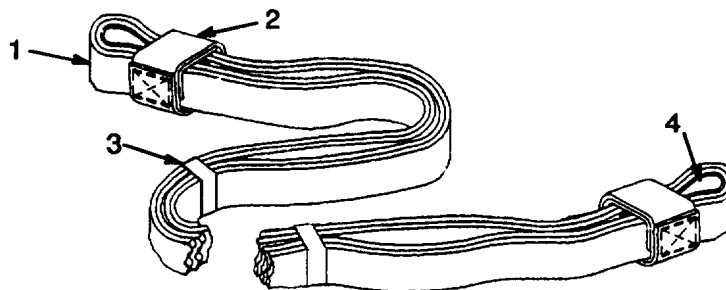
The following subparagraphs contain locations and descriptions of major components.

**Multi-Loop Line.** The multi-loop line (1) is constructed of type XXVI nylon. These lines are used for extraction lines, deployment lines, bag clustering lines, riser extensions, and suspension slings. They have a sliding webbing keeper (2) on each end and one or more fixed keepers (3) constructed of nylon filament pressure sensitive tape. They have buffers (4) on the inside of both loops.

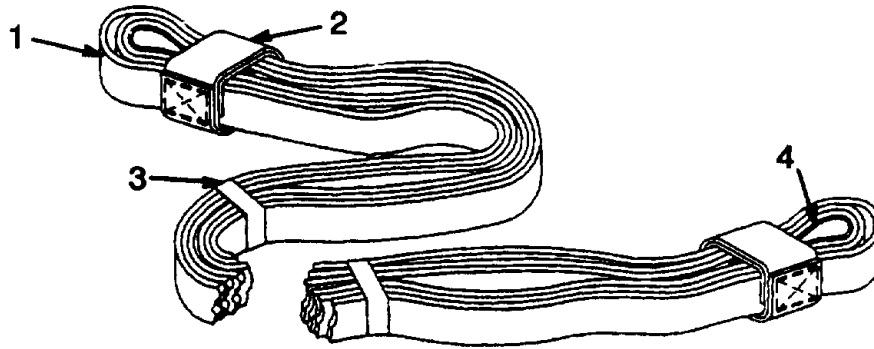
1. **One-Loop Line.** The one-loop lines are made in 36-, 60- and 160-foot (11.0- and 48.8-m) lengths. The 36-foot (11-m) one-loop line has no sliding keepers.



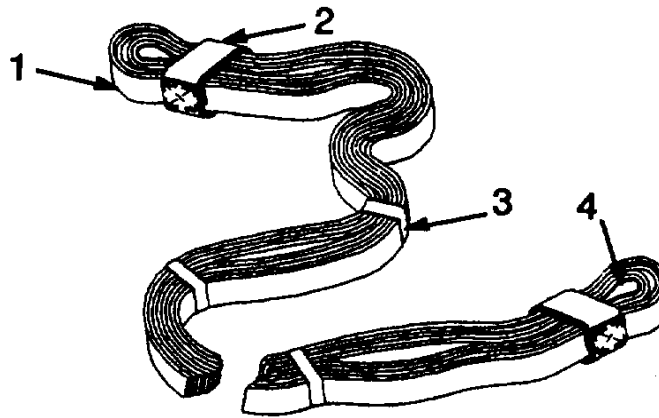
2. **Two-Loop Line.** The two-loop lines are made in 3-, 9-, 11-, 12-, 16-, 20-, and 120-foot (0.9-, 2.7-, 3.4-, 3.7-, 4.9-, 6.1-, 36.6-m) lengths.



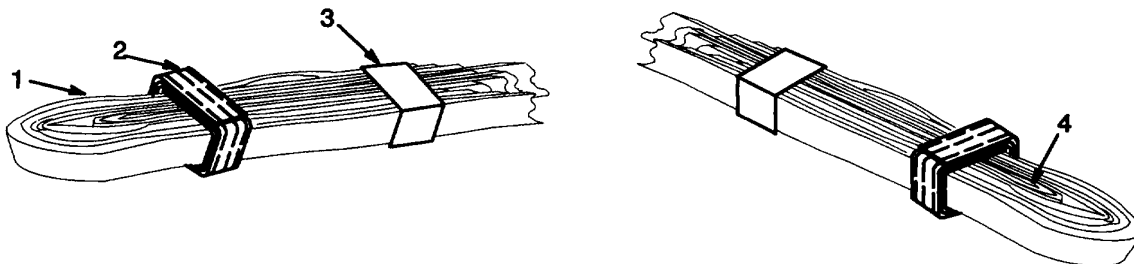
3. **Three-Loop Line.** The three-loop lines are made in 60- and 140-foot (18.3- and 42.7-m) lengths.



4. **Four-Loop Line.** The four-loop lines are made in 3-, 9-, 11-, 12-, 16-, 20-, and 28-foot (0.9-, 2.7-, 3.4-, 3.7-, 4.9-, 6.1-, 8.5-m) lengths.

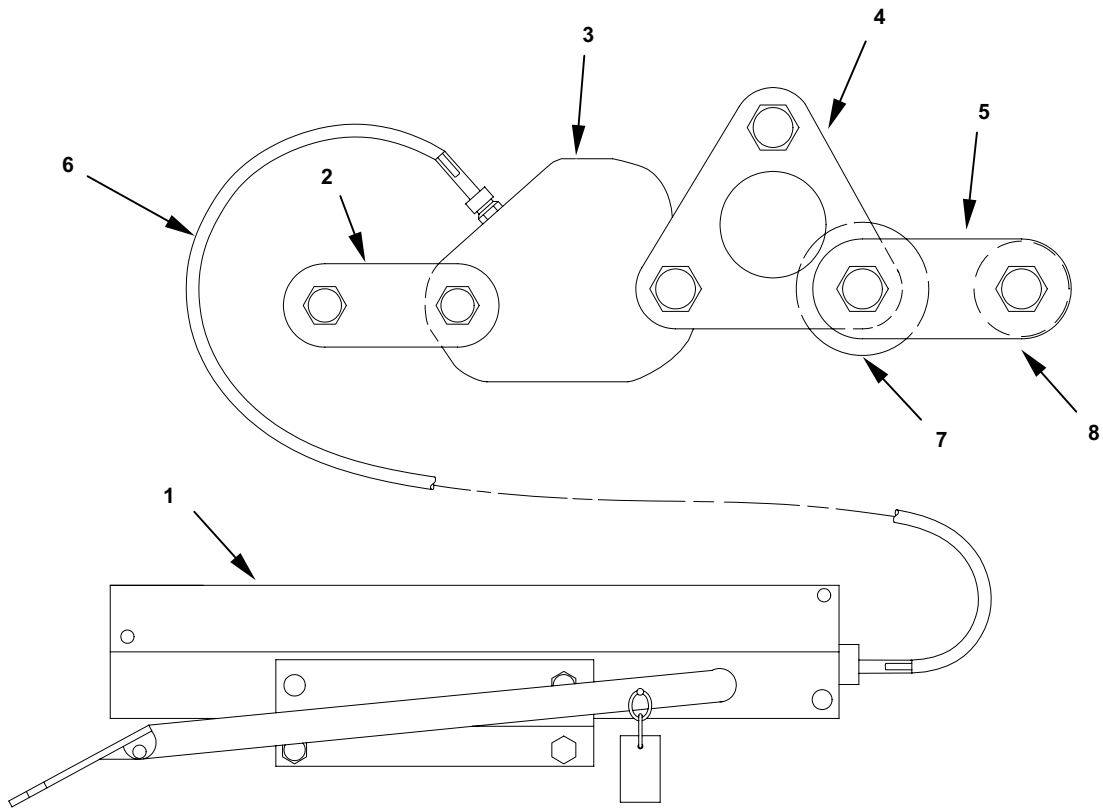


5. **Six-Loop Line.** The six-loop lines are made in 60- and 120-foot (18.3- and 36.6-m) lengths.





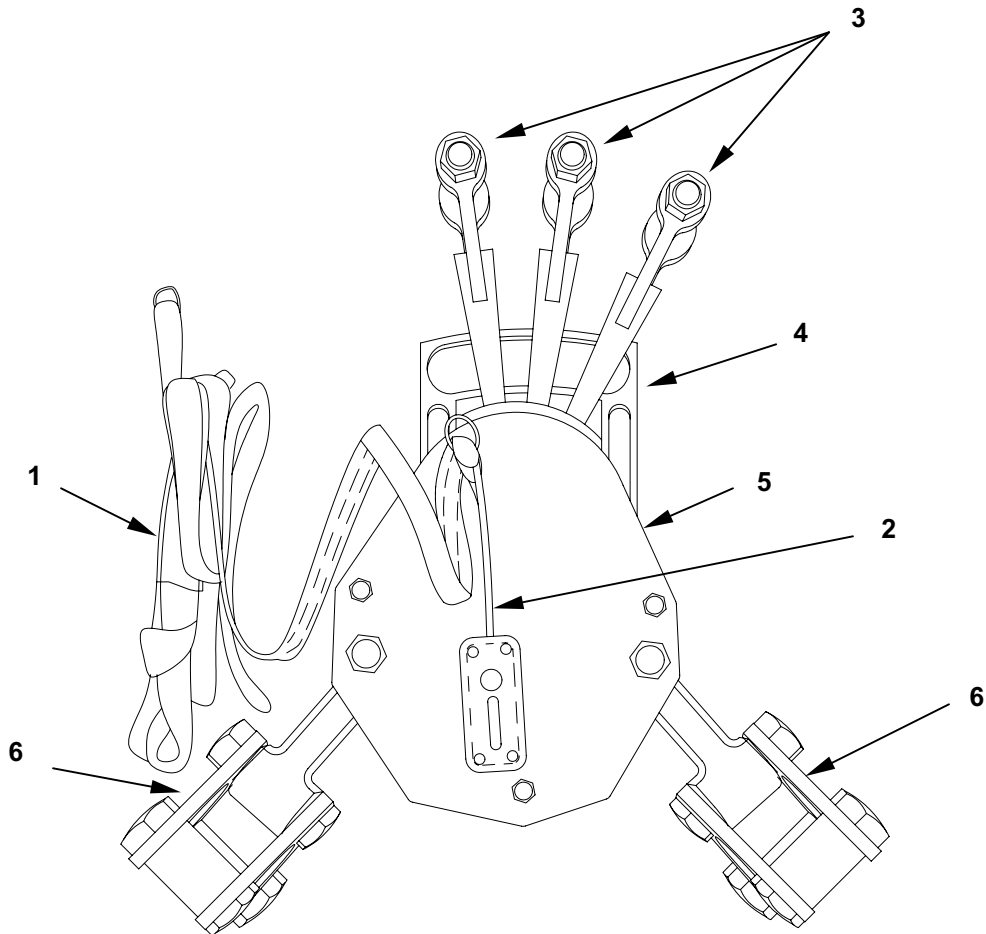
**Extraction Force Transfer Coupling.** The extraction force transfer coupling consists of an actuator assembly (1), connector, latch assembly (2), latch assembly (3), link assembly coupling, EFTC (4), a link assembly adapter (5), and a cable assembly (6). The coupling transfers the pull force of a cargo extraction parachute from the extracted airdrop load to the cargo parachute deployment line. Immediately after the load departs the aircraft, the arm of the actuator assembly (1) is released and pulls upon the cable assembly (6). The pull on this cable, in turn, causes the latch assembly (3) to release the link assembly (4), transferring the pull force. The cable assembly (6) is constructed in 12-, 16-, 20-, 24-, and 28-foot (3.7-, 4.9-, 6.1-, 7.3-, 8.5-m) lengths. The link assembly adapter (5) connects an extraction line to the link assembly (4). It is equipped with a larger spacer (7) and a small spacer (8) that distribute the extraction force applied to the link assembly by providing a two or three loop separation when a five and six-loop extraction line is used. The connector, latch assembly (2) connects the latch assembly (3) to the extraction bracket mounted on the platform.



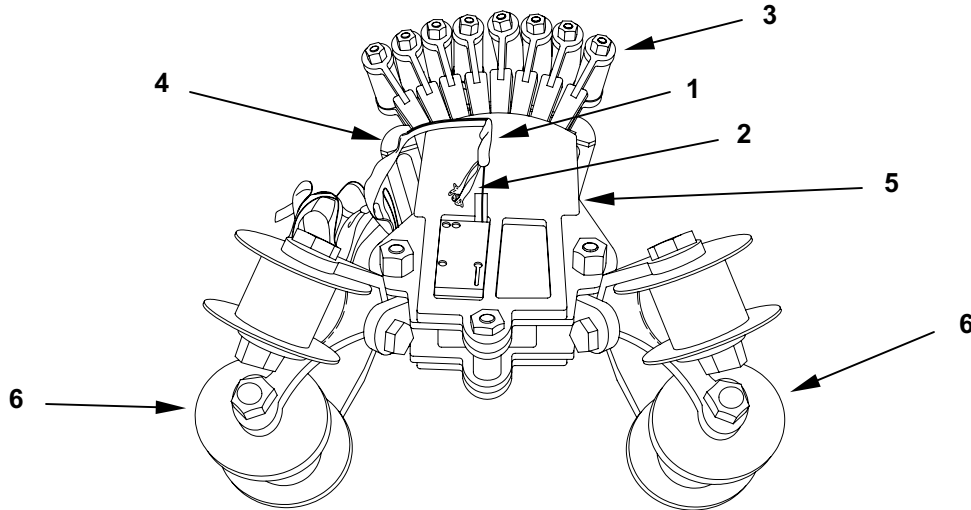
**M-1 Cargo Parachute Release.** The M-1 cargo parachute release consists of an arming wire lanyard (1), arming wire (2), parachute connectors (3), upper load suspension link (4), a timer delay assembly contained within the release body (5), and lower suspension links (6). A cargo parachute release separates medium (64-foot diameter G-12) or large (100-foot diameter G-11) cargo parachutes from an air dropped load upon ground contact. This prevents the dragging or overturning of the load by winds. The M-1 Cargo Parachute Release is designed for use in the airdrop of loads weighing from 200 to 15,000-pounds (90 to 6,800-kg). The M-1 release is capable of accommodating three G-11 or two G-12 cargo parachutes. The two lower suspension links connect to four airdrop platform suspension slings. Cargo parachutes are joined to the M-1 release by connectors that are held in place by a toggle mechanism. The parachutes separate when the release body tilts at a critical angle as the suspended load contacts the ground. The mechanical delay release timer prevents early separation. The timer is activated when the load parachute(s) begin to deploy, pulling on the arming wire lanyard (1) that is attached to an arming wire (2) installed in the release timer.

**NOTE**

The delay release timer, parachute release connector, arming wire, and arming wire lanyard are interchangeable for use between the M-1 and M-2 airdrop cargo parachute releases.



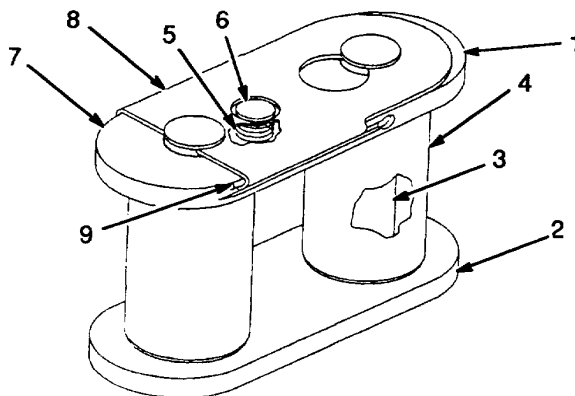
**M-2 Cargo Parachute Release.** The M-2 cargo parachute release is similar to the M-1 described in the paragraph above. It also consists of an arming wire lanyard (1), arming wire (2), parachute connectors (3), upper load suspension link (4), a timer delay assembly contained within the release body (5), and lower suspension links (6). It is designed for use in the airdrop of loads ranging in weight from 6,000 to 42,000-pounds (2,700 to 19,080-kg), using G-11 cargo parachutes. Because it handles heavier loads, the M-2 release can accommodate three to eight G-11 cargo parachutes. The lower suspension links (6) are connected to four airdrop platform suspension slings.



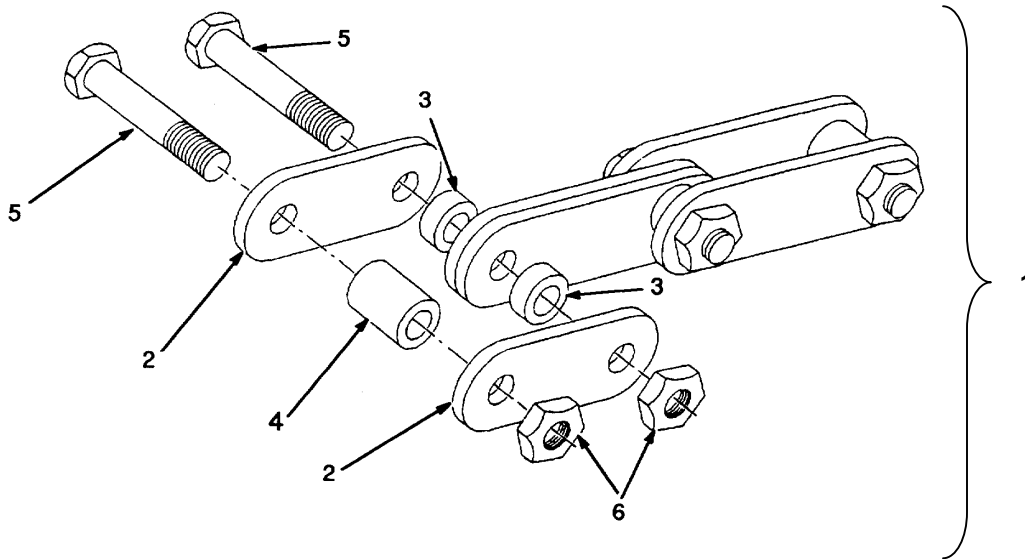
**Type IV Single Suspension Link Assembly.** The type IV single suspension link assembly (1) consists of a body (2), pins (3), rollers (4), spring (5), button (6), plate (7), and lock (8). Stops (9) on the side link plate prevent removal of the side link cover lock. This assembly is used in the formation of the extraction system. The Type IV link can also be used when a single extraction link is required.

**NOTE**

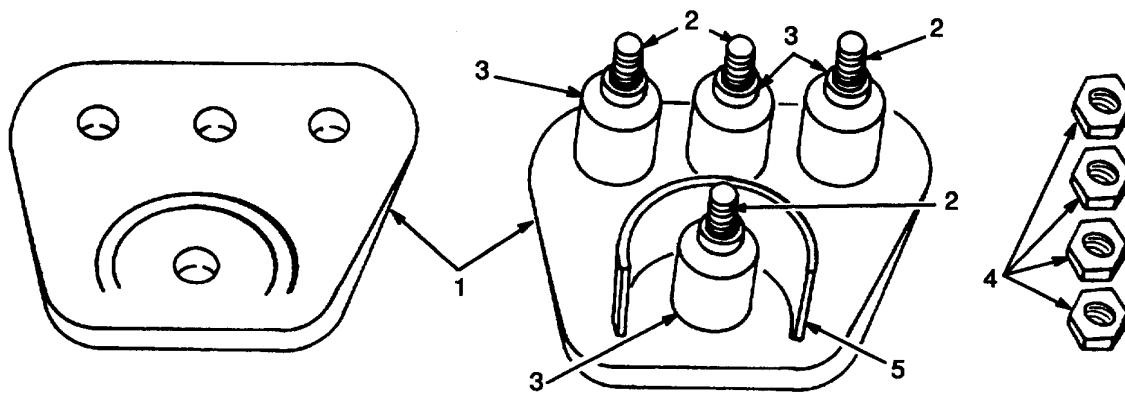
The type IV link assembly will not be authorized for LVAD use after 31 December 2003.



**Heavy-Duty Link Assembly.** The heavy-duty link assembly (1) is assembled as required using two 3 3/4- or 5 1/2-inch (9.5 or 14.0-m) side plates (2). They use spacer, sleeve, small (3) and large sleeve spacer (4), as required, and are secured with bolts (5) and nuts (6). Assemblies (also called two-point links) are used to join extraction lines to LVADS platform. The length used is determined by the load being rigged.



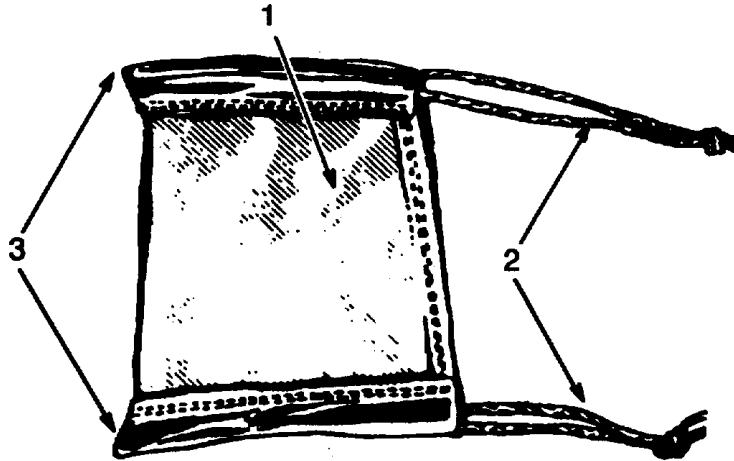
**4-Point Link.** The four-point link, also called the arm clustering assembly, provides for two extraction parachutes to be connected to the extraction line. It consists of two aluminum alloy side plates (1), and four bolts (2) with aluminum sleeves (3), four hexagon nuts (4), and a loop spacer (5).



**Type IV Link Cover.** The link cover (1) is used for covering a single link assembly. The cover is made of type III cotton duck cloth with a type III nylon cord drawstring (2) placed in a channel around each open end (3) of the cover.

NOTE

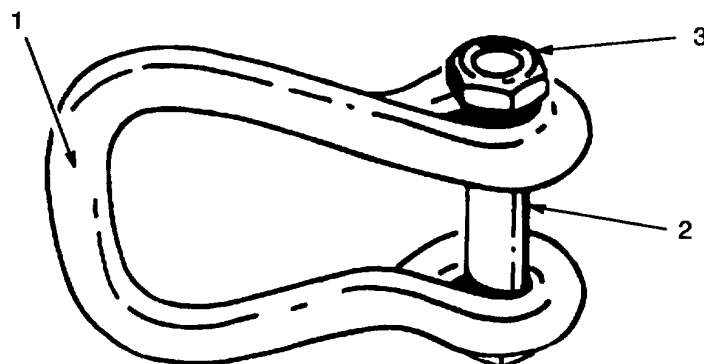
The type IV link assembly will not be authorized for LVAD use after 31 December 2003.



**Aerial Delivery Clevis.** There are two types of aerial delivery clevises. They consist of a clevis (1), cap screw (2), and nut (3). They are made in two sizes.

**¾-inch (1.9-cm) Clevis (medium clevis).** The ¾-inch (1.9-cm) clevis is used on the G-12 parachute, aft restraint provisions on the airdrop platform, and also used to replace the dual suspension link assemblies as the attaching points for the cargo slings.

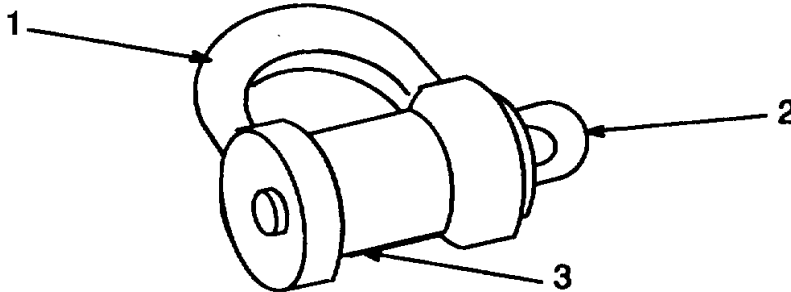
**1-inch (2.5-cm) Clevis (large clevis).** The 1-inch (2.5-cm) clevis is used on the G-11 parachute and at various points when rigging a load for airdrop.



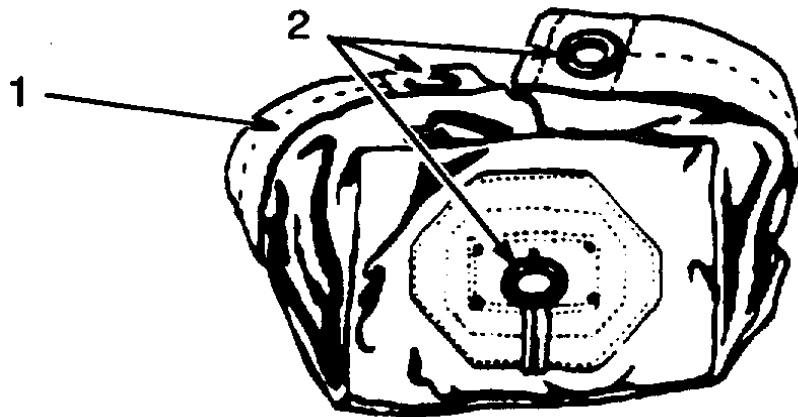
**1  $\frac{1}{8}$ -inch (2.9-cm) Screw Pin Clevis.** The screw pin clevis (1) that has a screw-pin (2) and 2-inch diameter sleeve (3) instead of a bolt and nut. It is used as an attachment for suspension sleeves.

**NOTE**

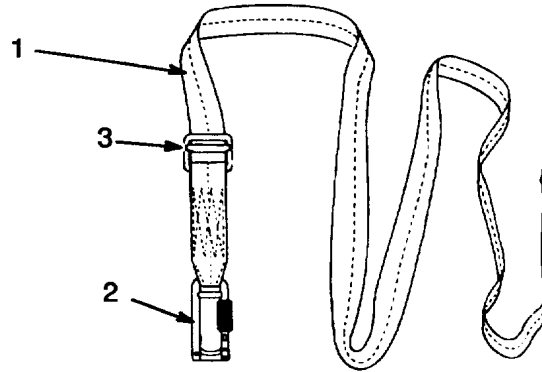
The only screw pin clevises authorized for use are the ones manufactured after January 1984. These clevises can be identified by their zinc chromate finish, which has a lustrous silver color.



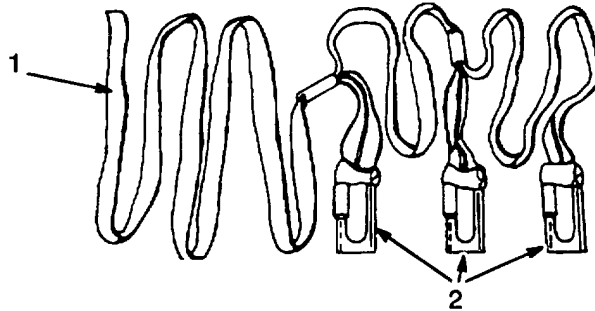
**Clevis Cover.** The clevis cover is made of type II cotton duck with a type VII cotton webbing (1) reinforcement and three brass grommets (2). The cover has a slot cut in the closed end to allow passage of the suspension slings. Grommets near the mouth of the cover permit tying the cover around the suspension clevis bolt and nut.



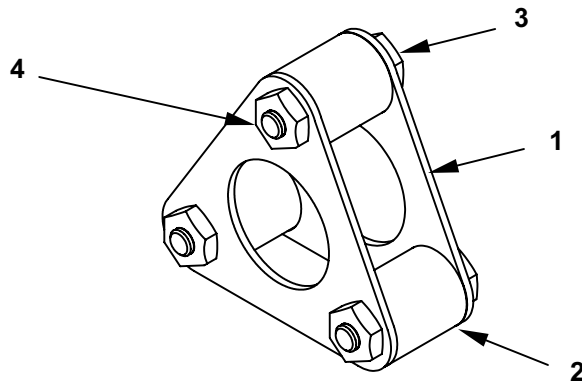
**Single Knife Parachute Release Strap.** This parachute release strap (1) is made of 1 3/4-inch wide by 8-foot-long (4.4-cm wide by 2.4-m long) type VIII cotton webbing. A release knife (2) is attached to one end of the strap and a quick-fit fastener (3) is attached 6-inches (15 cm) from the knife. This strap provides a means for cutting the parachute restraint strap, releasing the cargo parachutes from the load.



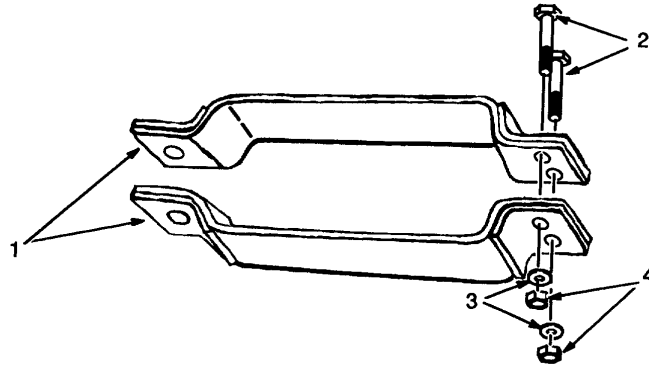
**Multi-Knife Parachute Release Strap.** The multi-cut parachute release strap is made of 1-inch-wide, 11-foot-long (2.5-cm wide, 3.4-m long), type III nylon webbing (1). Up to three release knives (2) can be attached to loops that are 10 1/2-inches (27-cm) long. The strap provides a means for cutting the parachute restraint strap, releasing the cargo parachute from the load.



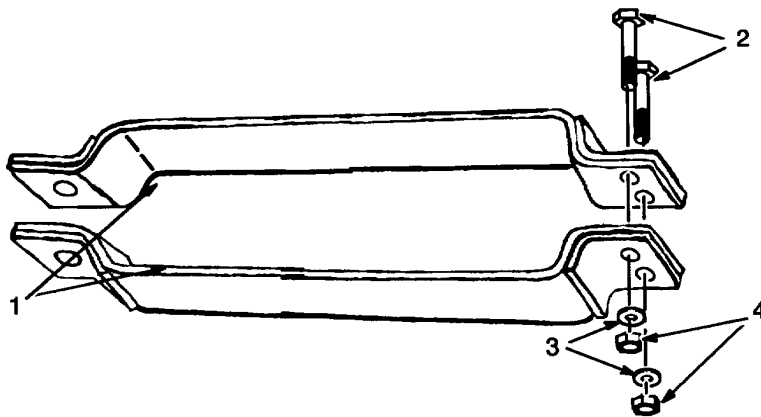
**3-Point Coupling Link Assembly.** The three-point link coupling assembly provides for three extraction parachutes to be connected to the extraction line. It consists of two aluminum alloy side plates (1), and three spacers (2) with 3 bolts (3) and hexagon nuts (4).



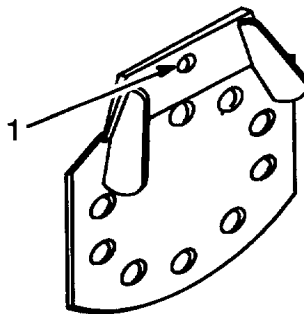
**M-35 Suspension Bracket.** The M-35 suspension bracket is secured to the rear frame on the M-34, M-35, M-35A1, and M-36C 2 ½-ton (2,300-kg) truck for airdrop. It is used as an attaching point for the suspension slings to the rigged load. The assembly consists of a left and a right side plate (1), two 5/8-inch hexagon cap bolts (2), two 5/8-inch lock washers (3), and two 5/8-inch hexagon nuts (4).



**M-59 Suspension Bracket.** The M-59 suspension bracket is secured to the rear frame on the M-59, 2 ½-ton (2,300-kg) drum truck for airdrop. It is used as an attaching point for the suspension slings to the rigged load. It consists of the same components used in the M-35 suspension bracket described above.

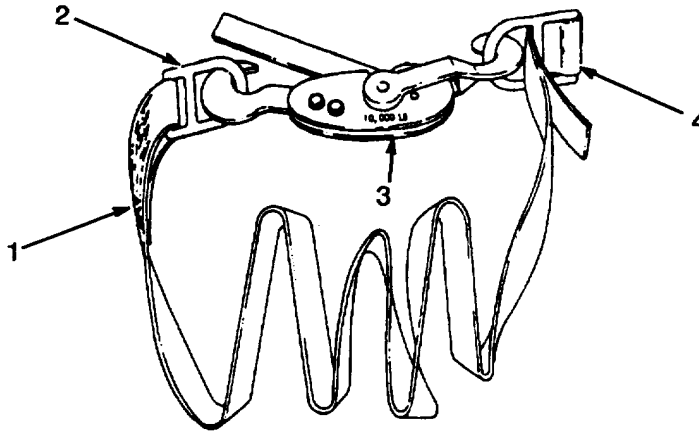


**Suspension Plate.** The suspension plate is secured to the wheel of the M-114A1, 155-mm howitzer for airdrop. It has a clevis pinhole (1) for attaching the steel clevis block assembly.

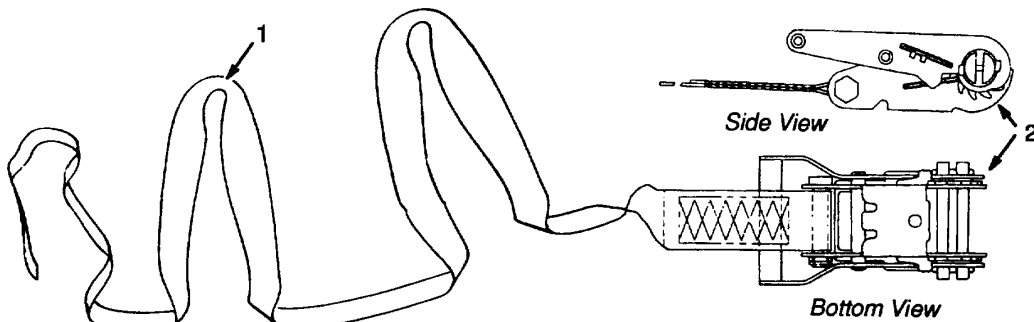




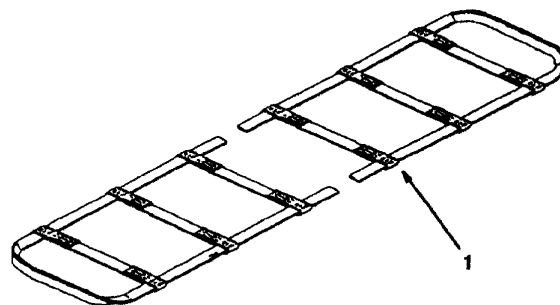
**10K Cargo Tie-down.** The 10,000-pound (4,500-kg) capacity cargo tie-down is used to secure equipment and supplies to an airdrop platform. The tie-down consists of a 15-foot-long (4.6-m long) by 1 3/4-inch wide (4.4-cm wide), type V, low elongation, polyester textile webbing strap (1) with a steel d-ring permanently attached to one end (2), a cargo tie-down load binder (3) that has an open hook on each end, and a sling steel d-ring (4).



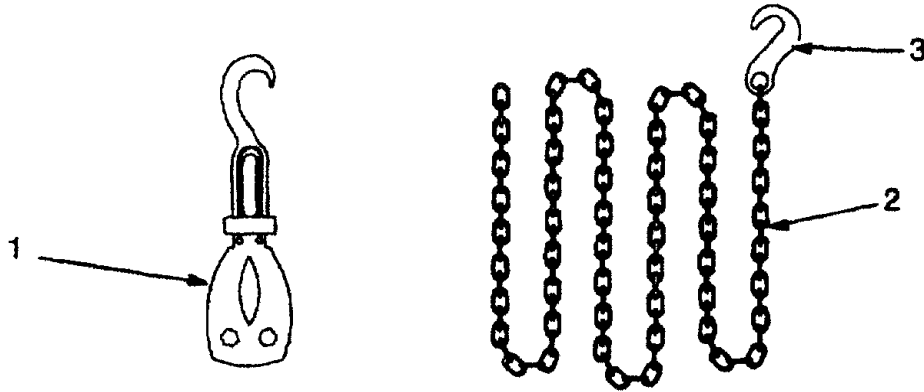
**Quick-Release Cargo Tie-down.** The quick-release tie-down consists of a 17-foot-long (5.2-m long) by 2-inch-wide (5.1-cm wide), type V webbing strap (1) with a quick-release lever (2).



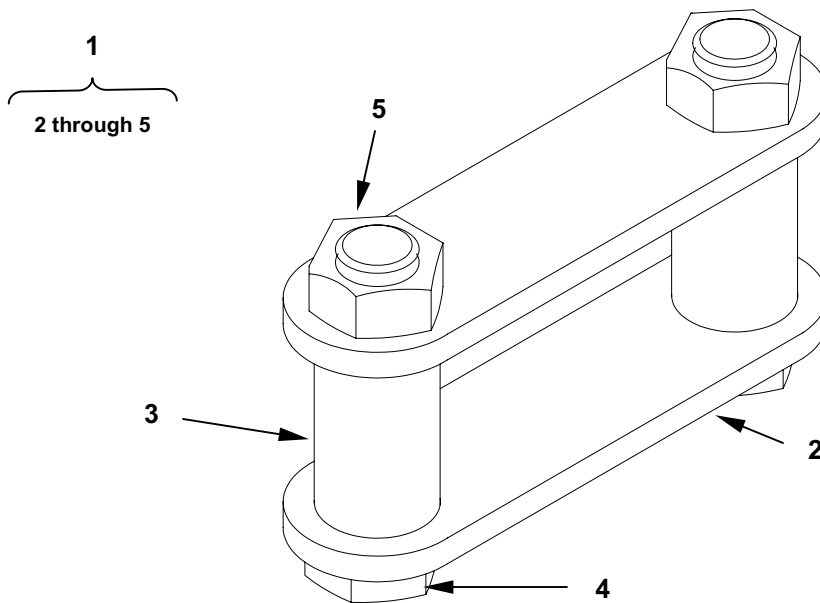
**Type IV Drive-Off Aid.** The drive-off aid is used to assist in the removal of a vehicle from an airdrop platform after the airdrop when the honeycomb will not allow the wheels to make contact with the platform. It consists of two traction webs (1).



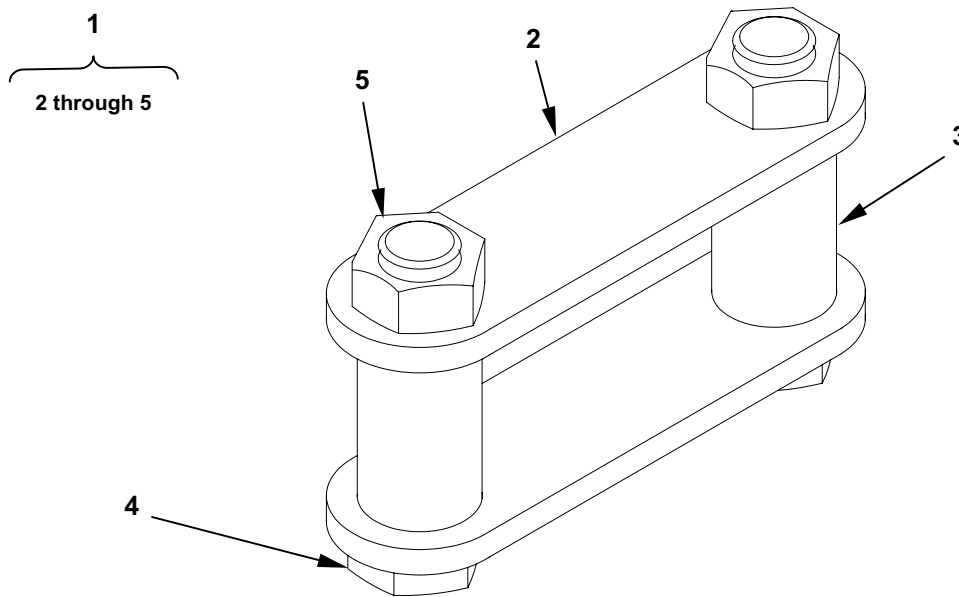
**Aircraft Cargo Tie-down.** The MB-1 and MB-2 aircraft cargo tie-downs consist of a 108-inch length of steel chain (2) with a grab hook (3) and a turn-buckle tightening device (1) with a quick-release lever. The MB-1 tie-down has a load capacity of 10,000-pounds (4,500 kg) and the MB-2 has a capacity of 25,000-pounds (11,200 kg). These tie-downs are used to secure rigged loads on the transport vehicle while in route to an aircraft and while installed inside an aircraft.



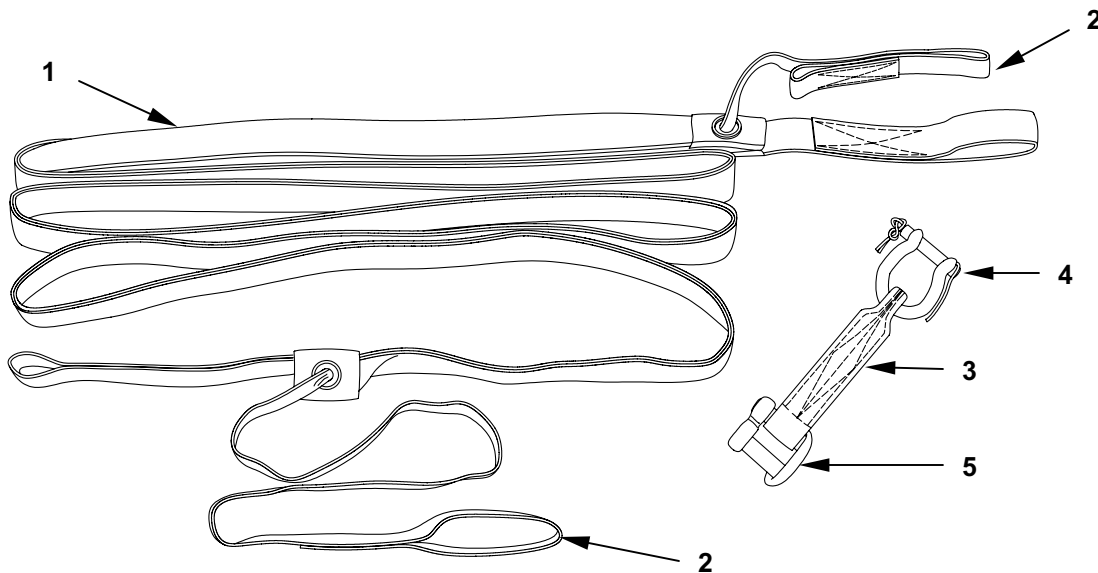
**3 3/4-Inch, 2-Point Link.** The 3 3/4-inch, 2-point link assembly (1) consists of two side plates (2), spacer, sleeve, large (3), and is secured with two bolts (4) and two nuts (5). This assembly (also called the 2-point link) is used to join extraction parachutes to the extraction system (line bag) for LVADS. The two-point link can also be used to join suspension slings or when a single extraction link is required.



**5 ½-Inch, 2-Point Link.** The 5 ½-inch, 2-point link assembly (1) consists of two side plates (2), spacer, sleeve, large (3), and is secured with two bolts (4) and two nuts (5). This assembly (also called the 2-point link) is used to join extraction parachutes to the extraction system (line bag) for LVADS. The two-point link can also be used to join suspension slings or when a single extraction link is required.

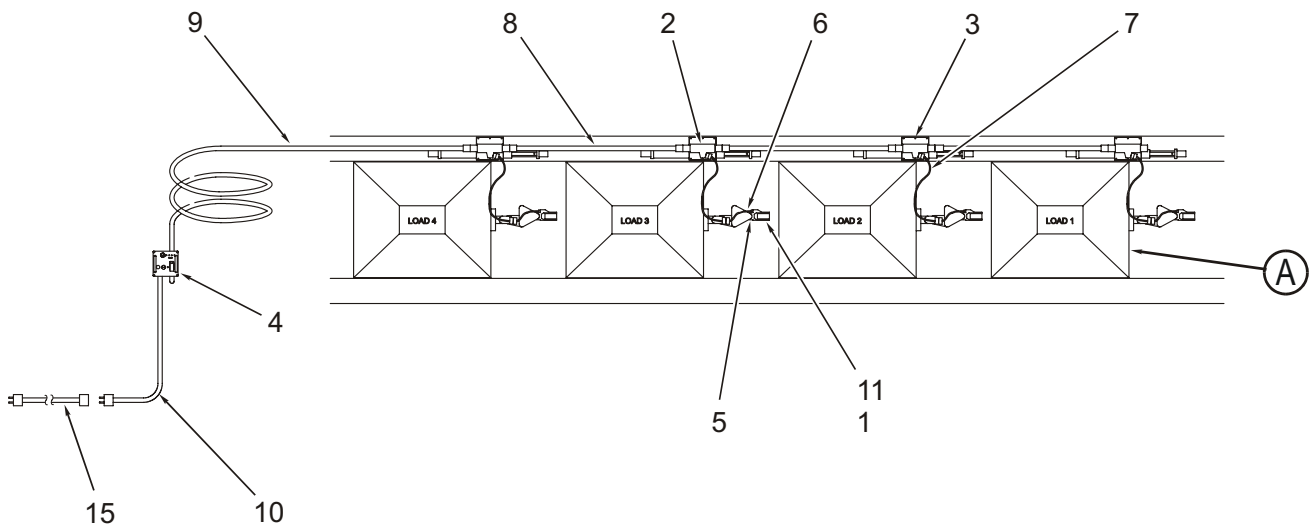


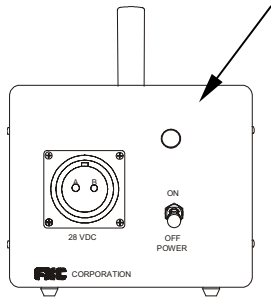
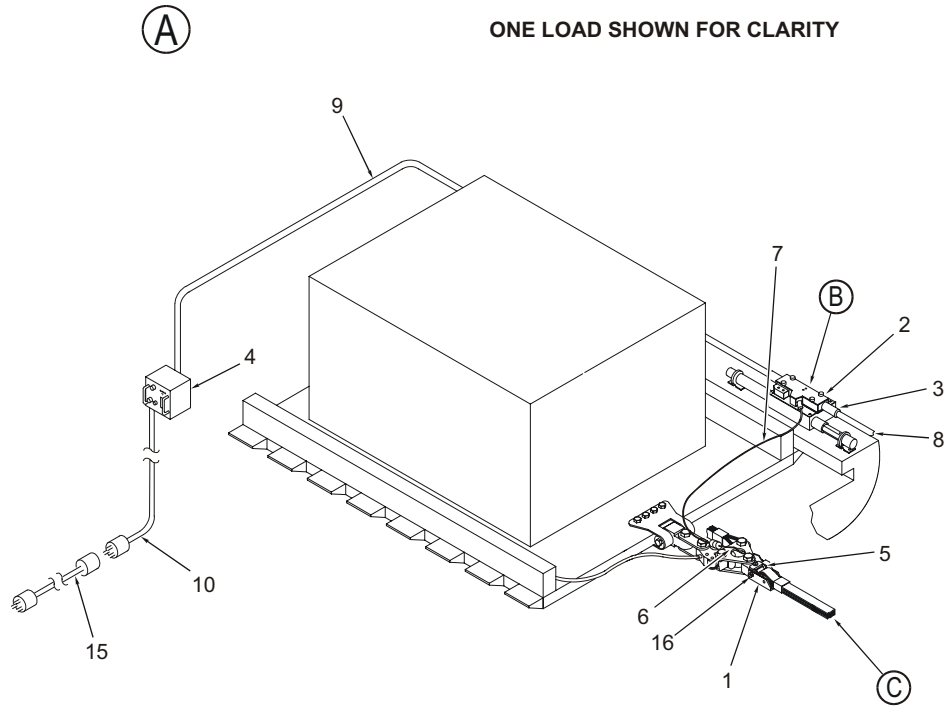
**Main Release Away Static Line.** The release away static line assembly (1) consists of 12-foot, 11 ½-inch length of fabricated type VIII nylon webbing sewn in such a way to allow an internal 14-foot, 8-inch release line (2) to freely move within the body of the static line and exit through two grommets. An additional 6 ½-inch connector strap (3) is required and is equipped with a G-14 clevis (4) and a 1-inch connector link (5). The release away static line is used to aid in the deployment of an extraction parachute rigged to deploy recovery parachutes for dual row airdrop.



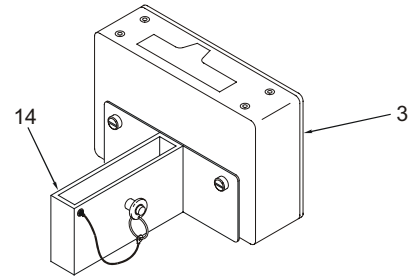
**Extraction Parachute Jettison System (EPJS).** The EPJS is designed for remote jettison of deployed extraction systems up to and including the extraction parachute. The EPJS is comprised of the components listed below. The system requires no modification to the aircraft and requires a 28 VDC power source. A power cable is provided to connect the system to the iron lung outlet of the aircraft. All cable connectors are keyed to prevent incorrect installation.

1. 4 EA Extraction Parachute Jettison Device (EPJD)
2. 4 EA Y-Connector
3. 4 EA Y-Connector Mounting Box (C-130; C-141; C-17)
- 4 EA Y-Connector Mounting Box (C-5 only)
4. 1 EA Control Box
5. 4 EA Squib (installed in EPJD)
6. 4 EA Squib Cable, 18-inch (yellow)
7. 4 EA Platform Cable, 10-foot (yellow)
8. 3 EA Interconnect Cable, 10-foot (black)
9. 1 EA Main Cable, 50-foot (black)
10. 1 EA Power Cable, 20-foot (red)
11. 4 EA Cover
12. 1 EA Kit Bag (not shown)
13. 4 EA Extension Cable, 4-foot (yellow) (C-5 and C-17 only) (not shown)
14. 4 EA Tie-down Bracket (C-5 only)
15. 1 EA Power Cable Extension, 20-foot (red) (C-17 only) (not shown)
16. 1 EA Power Cable Adapter, 1-foot (red) (C-5 only) (not shown)
17. 4 EA Safety Cap (installed in EPJD)
18. 4 EA Initiator Simulator (not shown)
19. 1 EA Squib Tester (not shown)
20. 1 EA 28 VDC Power Supply (not shown)

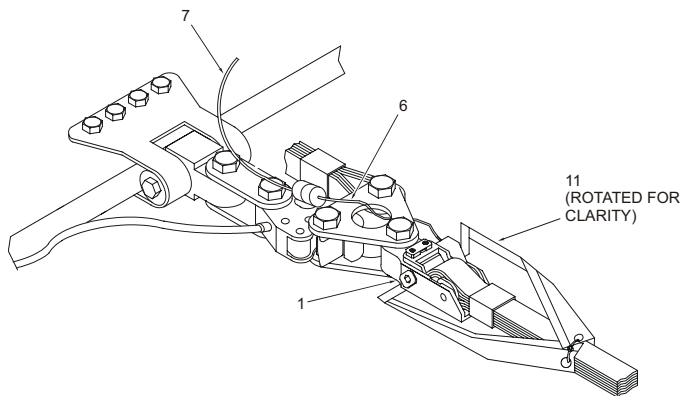




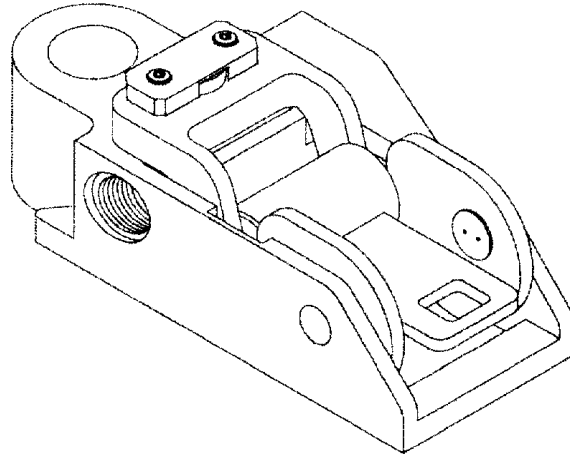
**(B)** FOR C-5 ONLY



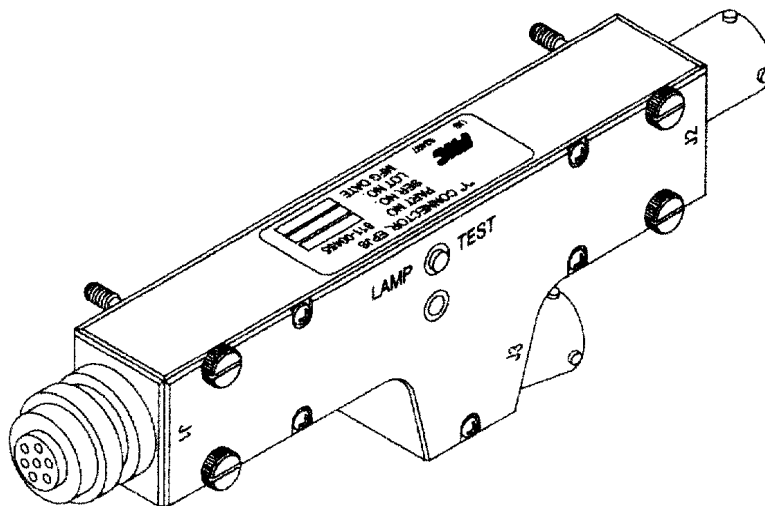
**(C)**



**Extraction Parachute Jettison Device (EPJD).** The EPJD couples the extraction line with the 3-point-link assembly. One device is required for each platform. In normal operation, the extraction parachute is deployed and the payload exits the aircraft. In the event the extraction parachute is deployed and the payload fails to exit the aircraft, the load master can activate the JETTISON SWITCH on the control box which fires the squibs in the system and releases the extraction parachute(s) from the payload(s).

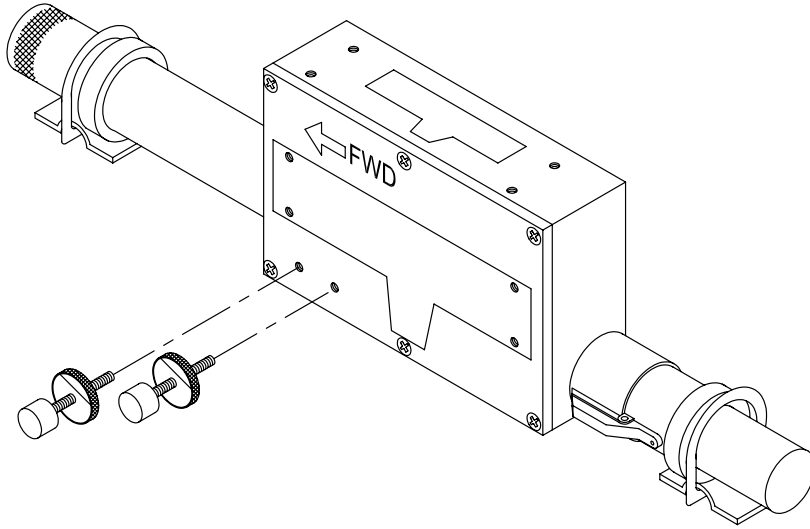


**Y-Connector.** The Y-connector contains a LAMP TEST switch, a blue indicator Light Emitting Diode (LED), a connector for the platform cable, and two connectors for the interconnecting cables. The LAMP TEST switch, when pressed, will illuminate the blue LEDs when the system is installed and powered ON. The LED, when lit, indicates that one or both circuits from the Y-connector to the squib are intact. The internal circuit contains capacitors for storing the energy required to fire the squibs and has solid-state switches that are actuated by the JETTISON SWITCH on the control box. The Y-connector is attached to the Y-connector mounting box; one set is used for each platform.

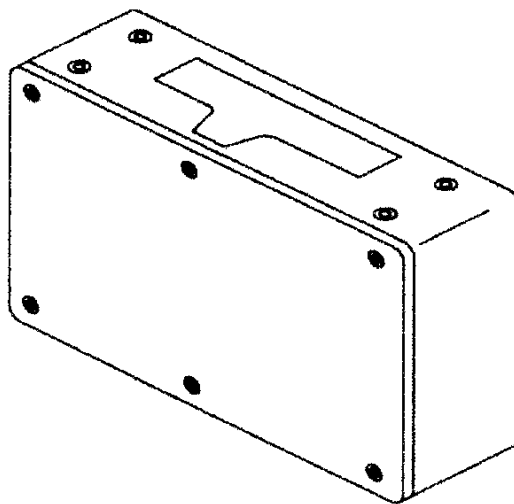


**Y-Connector Mounting Box.** The Y-connector mounting box is secured to the floor rings of the aircraft. The Y-connector mounting box is a die-cast aluminum box. The C-130, and C-17 mounting box is equipped with a mounting tube and extendable shaft. The C-5 mounting box does not have a mounting tube or shaft.

**Y-Connector Mounting Box (C-130; C-141; C-17)**



**Y-Connector Mounting Box (C-5)**



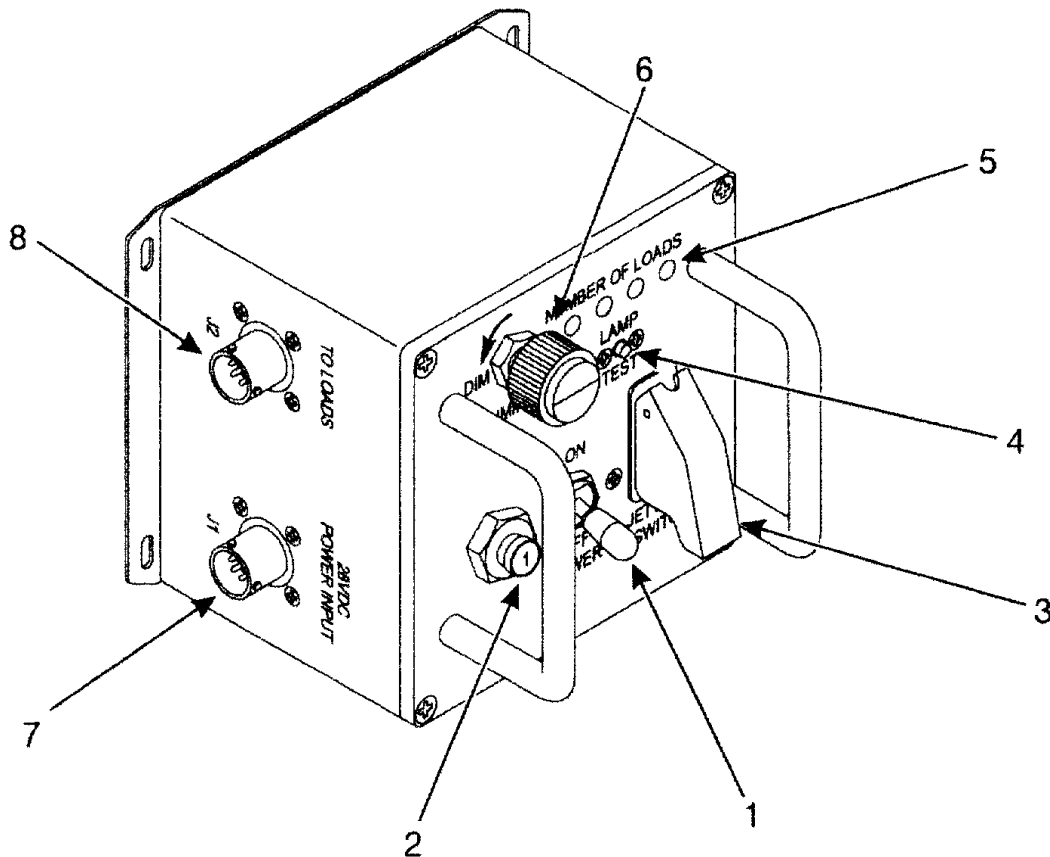
**Control Box.** The control box contains a power switch (1), and circuit breaker (2), a jettison switch (3), a lamp test switch (4), four blue LEDs (5), a dimmer adjust knob (6), a power input connector (7), and a connector (8) to the loads.

The POWER switch has a locking-lever to prevent it from being accidentally switched ON/OFF. The lock is released by pulling the switch handle out while moving the handle to either position. The switch should remain in the OFF position until the system is installed and ready for testing or use. Before switching the power ON, confirm that the JETTISON SWITCH is OFF to prevent the squibs from firing.

The circuit breaker is an aircraft type, 1-amp, trip-free, push-pull. The JETTISON SWITCH is guarded to prevent accidental firing of the squibs installed in the system. When the JETTISON SWITCH is activated, all the squibs installed in the system will fire, thus releasing all the extraction lines from their system.

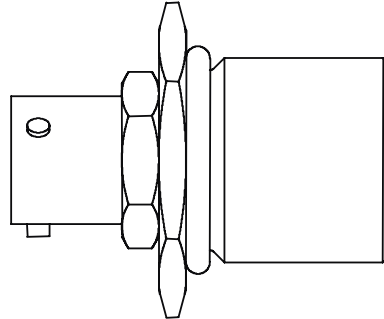
The LAMP TEST switch, when pressed, will illuminate the four blue LEDs on the control box when the system is installed and powered ON. The blue LEDs, when lit, only indicate the quantity of loads installed, not their location. If one load is installed, the left-most LED will illuminate. If two loads are installed, the two left-most LEDs will illuminate. If the quantity of illuminated LEDs does not match the quantity of loads installed, the LED on the Y-connectors should be observed to determine which load is not installed correctly.

The DIMMER adjust knob controls the brightness of the LEDs on the control and on the Y-connectors. Rotate the knob clockwise to increase the brightness, counter-clockwise to decrease the brightness. The cover of the control box may be rotated in relation to the two cable connectors depending on mission.

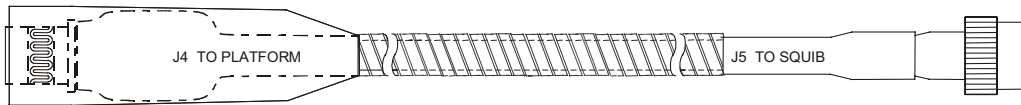




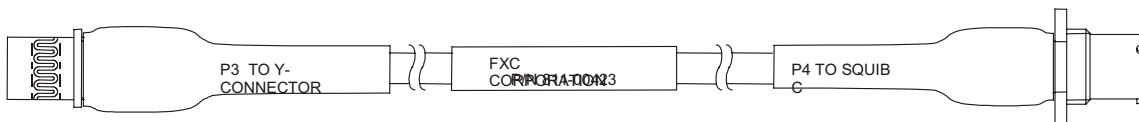
**Squib.** The squib is an electrically initiated gas-generated device. The squib is screwed into a closed chamber in the housing of the EPJD. When the fire signal is sent from the control box, the gas-generating material in the squib burns and creates a tremendous amount of pressure inside the system housing. This pressure is used to force a piston up against the latch of the system, thus breaking the shear bolt and releasing the extraction line.



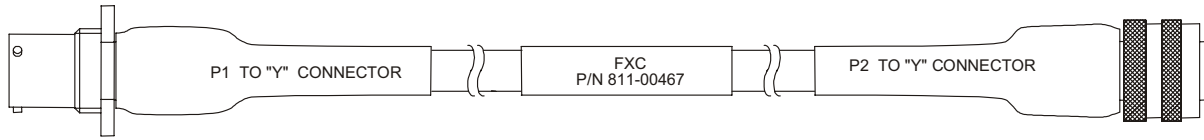
**Squib Cable.** The squib cable is used to connect the squib to the platform cable. The squib cable is 18-inches long and is protected with a flexible plastic-wrap cover to help prevent damage to the cable when the platform hits the ground. The plastic wrap can be easily removed and replaced during maintenance. The squib cable quick disconnects from the platform cable when the link assembly is released from the latch assembly.



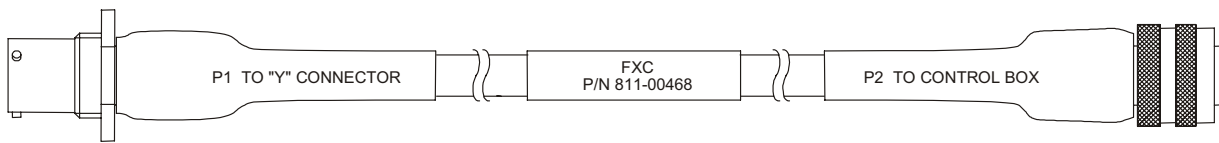
**Platform Cable.** The platform cable is used to connect the Y-connector to the squib cable. The connectors at both ends of the cable are modified to quick disconnect. The platform cable is 10-feet long and secured to the platform. As the platform exits the aircraft, the platform cable will disconnect from the Y-connector. After the link assembly is released from the latch assembly, the squib cable will disconnect from the platform cable.



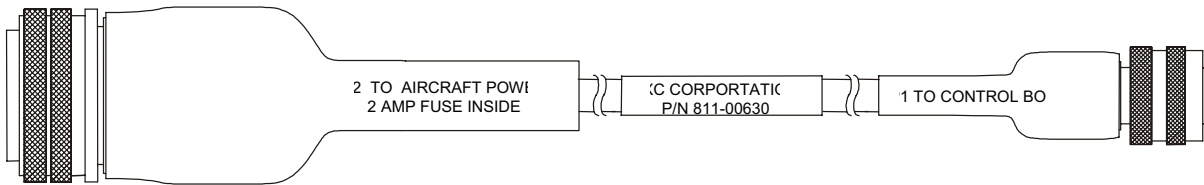
**Interconnect Cable.** The interconnect cable is 10-feet long and connects one Y-connector to another Y-connector. The interconnect cables may also be connected to each other without the Y-connector to produce a much longer cable for varying missions.



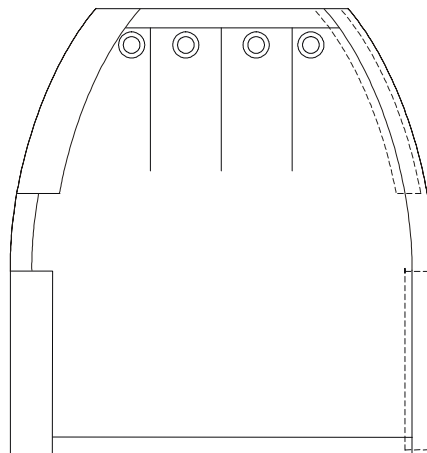
**Main Cable.** The main cable is a 50-foot cable used to connect the control box to the Y-connector.



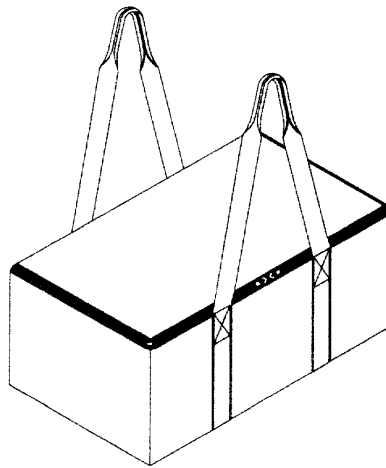
**Power Cable.** The power cable connects the control box to the 28 VDC iron lung power outlet in the aircraft. The C-5 and C-17 aircraft require adapter cables. The power cable is 20-feet long.



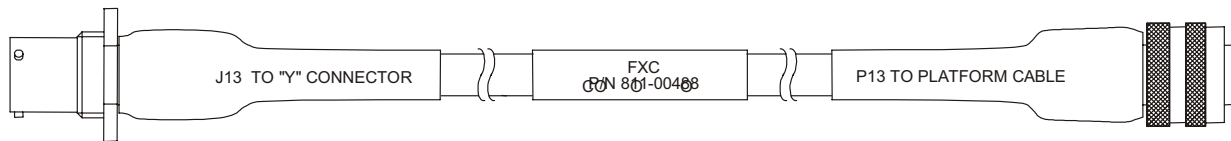
**Cover.** The cover is used to prevent metal-to-metal contact between the aircraft and the EPJD.



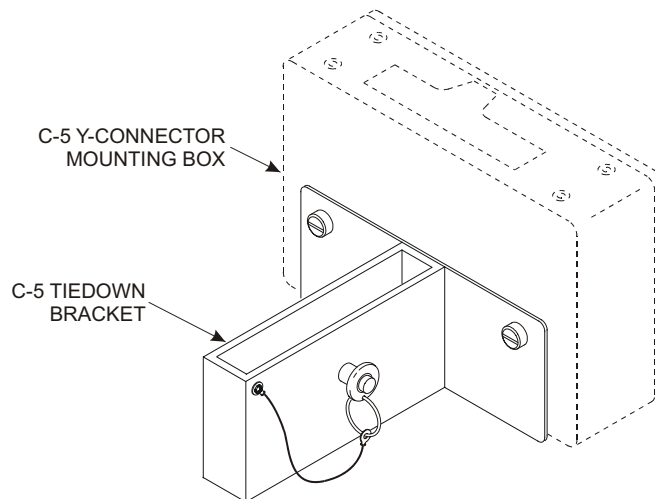
**Kit Bag.** The kit bag is used for storing the system components. There is a lower-level compartment used to store the control box, four Y-connectors, four Y-connector mounting boxes and C-5 mounting brackets and mounting boxes. The upper level compartment stores the cables.



**Extension Cable.** The C-17 and C-5 aircraft uses the basic EPJS equipment with the addition of an extension cable. Up to four extension cables (for the platform cables) can be used. Each extension cable is 4-feet long.



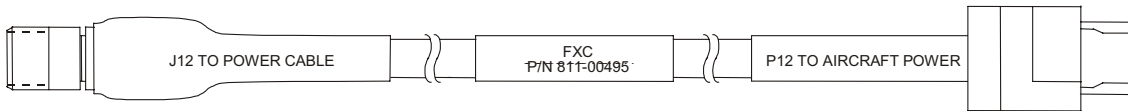
**Tie-down Bracket.** The tie-down bracket is used to provide a means to secure the Y-connector to the C-5 aircraft to ensure clean disconnects of cable during normal extraction.



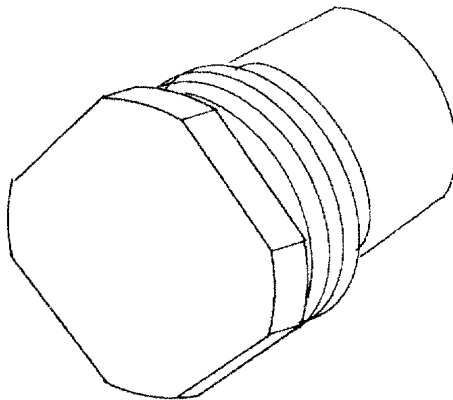
**Power Cable Extension.** The power cable extension is used to connect the aircraft power to the control box. The 20-foot long power cable extension provides aircraft 28 VDC power to the control box. The 20-foot cable is for the C-17 only; the 1-foot cable is for the C-5 only.



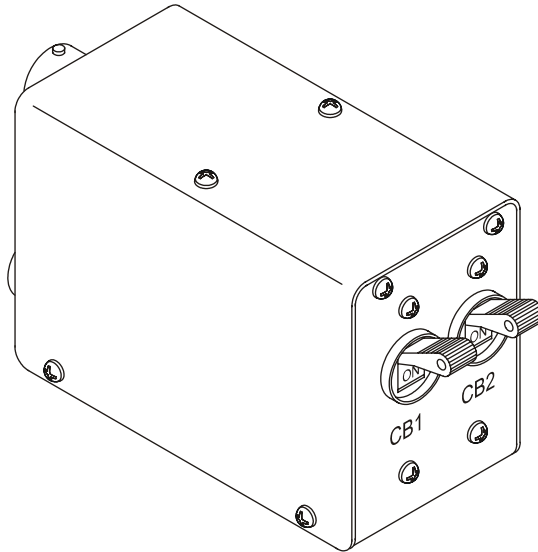
**Power Cable Adapter.** The C-5 aircraft uses the basic EPJS equipment. However, the standard 20-foot power cable must be adapted to plug into the 28 VDC iron long power outlet in the aircraft. The power cable adapter performs this function. The power cable adapter connects between the 20-foot power cable and the 28 VDC iron long power outlet.



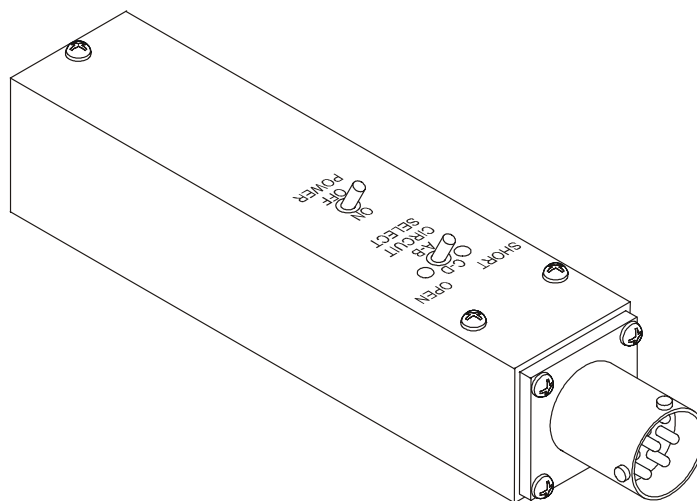
**Safety Cap.** The safety cap is used to prevent accidental firing of the squib. When plugged into the squib cable, which is in turn plugged into the squib, the squib contacts are shorted together, thus preventing any electrical charge from being applied to the squib. When not in use, the safety cap is stored by installing in the side of the EPJD.



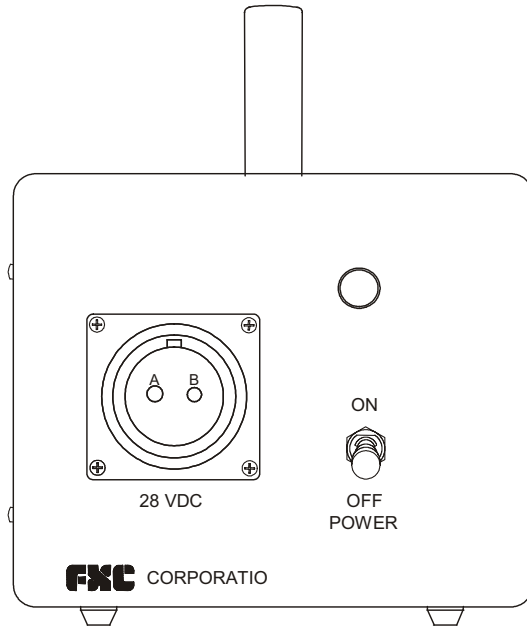
**Initiator Simulator.** The initiator simulator is used during testing of the EPJS to simulate the squib. When the EPJS components are connected and functioning properly, the initiator simulator will indicate if the EPJS jettison circuits are functioning properly. The initiator simulator has two small capacity circuit breakers that will operate (throw) from ON to OFF when 28 VDC is applied by setting the JETTISON SWITCH on the control box to ON. The squib has two redundant firing circuits. The two circuit breakers simulate these two redundant squib firing circuits.



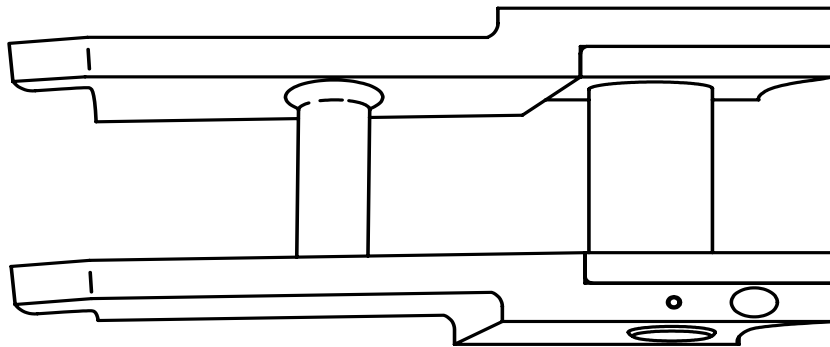
**Squib Tester.** The squib tester is used to confirm that the squib's two redundant firing circuits are properly wired and functioning. It allows the squib circuits to be tested without firing the squib. The squib contains two standard AAA batteries and two LED lamps. These lamps provide a positive indication of open and shorted squib firing circuits.



**28 VDC Power Supply.** The 28 VDC power supply supplies the needed power to test the assembled components of the EPJS prior to installation.



**Parachute Connector Link.** The Parachute Connector Link is used to attach the drogue line to the extraction parachute(s). In the event of an aborted drop, the drogue parachute may be jettisoned by activating the release mechanism which separates the jettison link section from the link assembly.



**EQUIPMENT DATA****Multi-Loop Line**

<b>Material:</b>	Type XXVI Nylon	
<b>Tensile Strength:</b>		
One-Loop Line	22,250-pounds	10,000 kg
Two-Loop Line	44,500-pounds	20,000 kg
Three-Loop Line	67,500-pounds	30,600 kg
Four-Loop Line	89,000-pounds	40,400 kg
Six-Loop Line	135,000-pounds	61,200 kg

**Extraction Force Transfer Coupling**

<b>Load:</b>	6,000-pounds	2,700 kg
--------------	--------------	----------

**Cable Assembly:**

12-foot long (3.7-m long) Weight	2.5-pounds	1.1 kg
-------------------------------------	------------	--------

16-foot long (4.9-m long) Weight	3.0-pounds	1.3 kg
-------------------------------------	------------	--------

20-foot long (6.1-m long) Weight	3.5-pounds	1.6 kg
-------------------------------------	------------	--------

24-foot long (7.3-m long) Weight	40-pounds	1.8 kg
-------------------------------------	-----------	--------

28-foot long (8.5-m long) Weight	4.5-pounds	2.0 kg
-------------------------------------	------------	--------

**Actuator Assembly:**

Length	18 <sup>3</sup> / <sub>8</sub> -inches	46 cm
Width	1-inch	2 cm
Height	3-inches	76 cm
Weight	11-pounds	5.0 kg

**Latch Assembly:**

Length	7-inches	17 cm
Width	2-inch	5 cm
Height	4 <sup>5</sup> / <sub>8</sub> -inches	11 cm
Weight	8-pounds	3.6 kg

**EFTC Coupling Link Assembly:**

Length	6-inches	15 cm
Width	3 1/16-inches	8 cm
Height	6-inches	15 cm
Weight	9-pounds	4.1 kg

**Latch Assembly Connector**

Length	5 1/4-inches	13.1 cm
Width	2 1/4-inches	5.6 cm

**Adapter Link Assembly:**

Length	12 1/4-inches	31 cm
Width	3 3/4-inch	9 cm
Height	2-inches	5 cm
Weight	6-pounds	2.7 kg

**M-1 Cargo Parachute Release**

**Capacities:**

Minimum	200-pounds	90.7 kg
Maximum	15,000-pounds	6,800 kg

**Performance:**

Parachute Adaptability One to three cargo parachutes in accordance with applicable FM 4.20 (FM 10-500) Series Publications

Type load use	Type V/Dual Row airdrop platform
Activation method	Arming cable
Actuation method	Timer delay

**Specifics:**

Gross weight	41-pounds	18.6 kg
Height	14-inches	36 cm
Width	8-inches	20 cm
Thickness	3 1/2-inches	89 cm

**M-2 Cargo Parachute Release**

**Capacities:**

Minimum	6,000-pounds	2,700 kg
Maximum	42,000-pounds	19,080 kg

**Performance:**



Parachute Adaptability	Three to eight cargo parachutes in accordance with applicable FM 4.20 (FM 10-500) Series Publications	
Type load use	Type V / Dual Row airdrop platform	
Activation method	Arming cable	
Actuation method	Timer delay	

**Specifics:**

Gross weight	73-pounds	33.1 kg
Height	17-inches	43 cm
Width	8-inches	20 cm
Thickness	3 ½-inches	89 cm

**Type IV Single Suspension Link Assembly**

Length	5-inches	13 cm
Width	2 7/8-inches	7 cm
Height	2-inches	5 cm

**NOTE**

The type IV link assembly will not be authorized for LVAD use after 31 December 2003.

**Heavy-Duty Link Assembly**

Length	Variable	
Width	2-inches	5 cm

**4-Point Link**

Length	8-inches	20 cm
Width	7-inches	18 cm

**Type IV Link Cover**

Material	Type III cotton duck cloth and Type III nylon cord	
Length	8-inches	20 cm
<b>Width:</b>		
Top	7-inches	18 cm
Bottom	5-inches	13 cm
<b>Cord Length:</b>		
Top	28-inches	71 cm
Bottom	24-inches	61 cm

**Aerial Delivery Clevis****3/4-inch (1.9 cm) Clevis; Medium G-12:**

Length	6 5/8-inches	16 cm
Width	6-inches	15 cm

**1-inch (2.5 cm) Clevis; Large G-11:**

Length	8 1/2-inches	21 cm
Width	6-inches	15 cm

**Screw Pin Clevis:**

Length	9-inches	23 cm
Width	2-inches	5 cm

**Clevis Cover**

Material	9.85 ounce cotton duck cloth Type II and VIII cotton webbing and brass grommets, size #4
----------	------------------------------------------------------------------------------------------

**Single Knife Parachute Release Strap****Strap:**

Material	Type VIII cotton webbing	
Length	8-feet	2.4 m
Width	1 3/4-inches	3 cm
Tensile strength	2,900-pounds	1,300 kg

**Fastener:**

Material	Steel
Release Knife	Steel

**Multi-Knife Parachute Release Strap**

Material	Type III nylon webbing	
Length	11-feet	3.4 m
Width	1-inch	3 cm

**3-Point Coupling Link Assembly**

Length	6-inches	15 cm
Width	3 1/16-inches	8 cm
Height	6-inches	15 cm
Weight	9-pounds	4.1 kg

**M-35 Suspension Bracket**

Length	24 ½-inches	62 cm
Width	3 5/8-inches	9 cm

**M-59 Suspension Bracket**

Length	28 ¼-inches	72 cm
Width	3-inches	8 cm

**Suspension Plate**

Length	20 ¼-inches	51 cm
Width	15-inches	38 cm
Max Depth	4 ¾-inches	12 cm

**10K Cargo Tie-Down**

**Strap:**

Material	Type V low-elongation polyester textile webbing	
Tensile strength	10,000-pounds	4,500 kg
Length	15-feet	4.6 m
Width	1 ¾-inches	4.4 cm

**Quick-Release Cargo Tie-Down**

**Strap:**

Material	Type V low-elongation polyester textile webbing	
Tensile strength	10,000 pounds (4536 kg) when used in a loop configuration	

Length	17-feet	5.2 m
Width	2-inches	5 cm

**Fastener:**

Width	Approx. 4-inches	10 cm
Length	7 ½-inches	19 cm
Depth	2 3/8-inches	6 cm

**Type IV Drive-Off Aid**

Material	Type XVIII nylon webbing	
Length	19-feet 6-inches	5.94 m
Width	10-inches	25 cm

**Aircraft Cargo Tie-down**

Length of Chain	108-inches	2.74 m
-----------------	------------	--------

**Load Capacity:**

MB-1	10,000-pounds	4,500 kg
MB-2	25,000-pounds	11,300 kg

**3 ¾-inch, 2-Point Link**

Length	6 ¼-inches	15.6 cm
Width	2 ½-inches	6.2 cm

**5 ½-inch, 2-Point Link**

Length	8-inches	20 cm
Width	2 ½-inches	6.2 cm

**Release Away Static Line Assembly**

Length	12-feet, 11 ½-inches	179 cm
Width	1, 1/8-inches	2.8 cm

**Extraction Parachute Jettison Device (EPJD)**

Length	8 ¼-inches	21 cm
Width	3-inches	7.6 cm
Height	4-inches	10 cm
Weight	10 ½-pounds	5 kg

**Y-Connector**

Length	9 ¼-inches	23.5 cm
Width	2 ¾-inches	7 cm
Height	1 ¼-inches	3 cm
Weight	1 ¼-pound	0.6 kg

**Y-Connector Mounting Box (C-130; C-141; C-17)**

Material	Aluminum/Fiberglass	
Length	29 ½-inches	75 cm
Width	4 ¾-inches	12 cm
Height	3 ⅓-inches	8.4 cm
Weight	2 ½-pounds	1.1 kg

**Y-Connector Mounting Box (C-5 only)**

Material	Aluminum	
Length	7 ⅓-inches	18.7 cm
Width	4 ¾-inches	12 cm
Height	2 ¼-inches	5.6 cm

**Control Box**

Length	5 ¾-inches	15 cm
Width	4 ¾-inches	12 cm
Height	5 ¾-inches	13 cm
Weight	1 ¾-pounds	0.8 kg

**Squib**

Length	1 ⅜-inches	3.5 cm
Width	1-inches	2.5 cm
Height	1-inches	2.5 cm
Weight	1 ½-ounces	0.04 kg

**Squib Cable**

Length	18-inches	46 cm
Weight	0.2-pounds	0.09 kg

**Platform Cable**

Length	120-inches	3.04 m
Weight	9-ounces	0.25 kg

**Interconnect Cable**

Length	120-inches	3.04 m
Weight	12-ounces	0.34 kg

**Main Cable**

Length	600-inches	15.2 m
Weight	53-ounces	1.5 kg

**Power Cable**

Length	240-inches	6.1 m
Weight	1-pound	0.45 kg

<b>Cover</b>		
Material	Cotton Duck Cloth	
Length	14 ¼-inches	36 cm
Width	14 ¾-inches	12 cm
Weight	8-ounces	0.23 kg
<b>Kit Bag</b>		
Material	Cordura Cloth 1000 Denier	
Weight	178-ounces	5 kg
<b>Extension Cable (C-5 and C-17 only)</b>		
Length	48-inches	1.2 m
Weight	0.6-pounds	0.27 kg
<b>Tie-down Bracket (C-5 only)</b>		
Length	6-inches	15.25 cm
Width	4 ⅔-inches	11.8 cm
Height	3-inches	7.6 cm
<b>Power Cable Extension (C-17 only)</b>		
Length	240-inches	6.1 m
Weight	20-ounces	0.57 kg
<b>Power Cable Adapter (C-5 only)</b>		
Length	12-inches	30.5 cm
Weight	0.6-ounces	0.27 kg
<b>Safety Cap</b>		
Length	1-inches	2.6 cm
Width	1 ¼-inches	3.2 cm
Height	1 ¼-inches	3.2 cm
Weight	1-ounce	0.03 kg
<b>Initiator Simulator</b>		
Length	4-inches	10.16 cm
Width	2-inches	5.08 cm
Height	2 ¾-inches	6.99 cm
Weight	Not available	Not available
<b>Squib Tester</b>		
Length	5 ¾-inches	14.61 cm
Width	1.13-inches	2.87 cm
Height	1.13-inches	2.87 cm
Weight	Not available	Not available

**28 VDC Power Supply**

Length	10-inches	25.40 cm
Width	6-inches	15.24 cm
Height	5-inches	12.70 cm
Weight	Not available	Not available

**Parachute Connector Link**

Length	7 1/2-inches	18.5 cm
Width	3 1/4-inches	8.5 cm
Height	1 1/2-inches	4 cm
Weight	5-pounds	2.27 kg

**END OF WORK PACKAGE**





**CHAPTER 2**

**OPERATOR MAINTENANCE INSTRUCTIONS  
FOR  
ANCILLARY EQUIPMENT FOR  
LOW VELOCITY AIR DROP SYSTEMS (LVADS)**



---

## ANCILLARY EQUIPMENT FOR LOW VELOCITY AIR DROP SYSTEMS (LVADS) SERVICE UPON RECEIPT

---

### THIS TASK COVERS:

- Overview
  - Initial Receipt
  - Common Tools and Equipment
  - Special Tools and Equipment
  - Repair Parts
- 

### INITIAL SETUP:

#### Personnel Required

92R (10) Parachute Rigger

#### Equipment Condition

All equipment shall be serviceable and ready for use.

---

### OVERVIEW

This chapter contains information necessary to maintain the ancillary equipment for the Low Velocity Air Drop System at the unit maintenance level, in accordance with the Maintenance Allocation Chart (MAC) for the equipment. It includes the following:

1. Procedures for processing new or used ancillary equipment upon receipt.
2. Assembly of components prior to rigging.
3. Preventive maintenance procedures to ensure continued serviceability of all components.
4. As required inspections and maintenance procedures performed prior to assembly/rigging.
5. Detailed assembly procedures.
6. Repair methods and repair, or replacement, procedures for all components of the ancillary equipment are listed and illustrated in the unit maintenance procedures of this manual, WP 0007 00 through WP 0060 00.

### INITIAL RECEIPT

The following describes the procedures for processing ancillary equipment upon initial receipt.

**General Procedures for Air Delivery Equipment.** When any of the LVADS Ancillary Equipment is initially received from a supply source and issued to a using unit, the items will be unpacked from the shipping containers and inspected by a qualified parachute rigger. The inspection performed will be a technical/rigger-type inspection that will be conducted as authorized in WP 0007 00, INSPECTION. Upon completion of the inspection, the items will be tagged as prescribed in DA PAM 738-751. Serviceable equipment may then be entered either into storage or into use in airdrop operations, as applicable. An unserviceable item will be held and reported in accordance with WP 0007 00, INSPECTION.

**Inspection Personnel.** Personnel other than parachute rigger personnel may assist in the unpacking process of initially received components, as directed by the local air delivery equipment maintenance officer. However, the maintenance officer will ensure the entire unpacking effort is conducted under the direct supervision of a qualified parachute rigger (MOS 92R).

Remember that acceptance of new airdrop equipment from manufacturers is based upon inspections made of sample lots that have been randomly selected in accordance with military standards.

Changes will sometimes evolve for the original design and occasionally contractors are authorized deviations of material and construction techniques. Airdrop equipment that has been in the field cannot be expected to meet exact manufacturing specifications, however, the equipment should closely reflect desired design characteristics.

Since repairs, modifications, and/or changes can alter or detract from the original configuration, such equipment shall be air worthy, safe, and adequate for its intended use.

**Unpacking.** Each component of the LVADS Ancillary Equipment is separately packaged. Use care when unpacking equipment to avoid damage. Save all containers, shipping cartons, and crates for reuse when possible.

### Checking Unpacked Equipment

1. Inspect the equipment for damage incurred during shipping. If the equipment has been damaged, report damage on an SF 364, Report of Discrepancy. USAF personnel use SF 364 IAW T.O. 00-35D-54, USAF (Deficiency Reporting and Investigating System) and AFI 21-115 (Deficiencies Across Component Lines) Chapter 5.
2. Check the equipment against the packing slip to see if the shipment is complete. Report all discrepancies in accordance with the instructions of DA PAM 738-750 or DA PAM 738-751, as applicable. USAF personnel use SF 364 IAW T.O. 00-35D-54, USAF (Deficiency Reporting and Investigating System) and AFI 21-115 (Deficiencies Across Component Lines) Chapter 5.
3. Note damage on DA Form 2404, Equipment Inspection and Maintenance Worksheet, and initiate corrective maintenance procedures in accordance with Section VI of this chapter. USAF personnel use DD Form 2332 (Material Deficiency Exhibit).

### Processing Unpacked Equipment

1. Only a qualified parachute rigger shall accomplish the processing of unpacking airdrop equipment.
2. Check DA PAM 25-30 for Maintenance Work Orders (MWO) applicable to your equipment. If any MWOs are listed, check DA Form 2408-5, Equipment Modification Record, to see if MWOs have been applied to the equipment. The MWO number will be shown near the equipment nomenclature label. If a current MWO is listed in DA PAM 25-30, but there is no evidence that it has been applied to the equipment you are processing, note the discrepancy on DA Form 2404, Equipment Inspection and Maintenance Worksheet.
3. Inspect the items as outlined in WPs 0005 00 and 0006 00, PMCS, and WP 0007 00, INSPECTION.
4. Clean and dry the LVADS Ancillary Equipment according to WP 0008 00. A compressed air hose may be used to remove foreign material from inaccessible locations.

**Parachute Log Record.** The Army Parachute Log Record, DA Form 3912, is a history-type maintenance document, which accompanies the item through the period of service of the individual assembly. The log record provides a means of recording maintenance actions performed on the item.

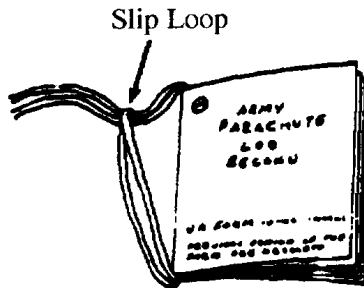
Normally, a log record is initiated and attached to the item upon receipt by a using unit. However, if the item is subjected to alteration or modification by a maintenance activity during the interim period from date of manufacture to receipt by a using unit, the log record will be prepared by the activity performing the maintenance function.

Once initiated, a log record will be attached to and contained on the item until such time as the item is destroyed or rendered unfit for further use or repair.

Additionally, should an item that requires a log record be transferred from one unit to another, the log record for the item will accompany the item in the transfer action. A prepared log record will not be removed or separated from the item, except as directed by the local airdrop equipment maintenance activity officer. A log record which is illegible, lost, damaged, soiled, or precludes further entries due to lack of space will be replaced upon the next repack or inspection, as applicable, with a serviceable item from stock.

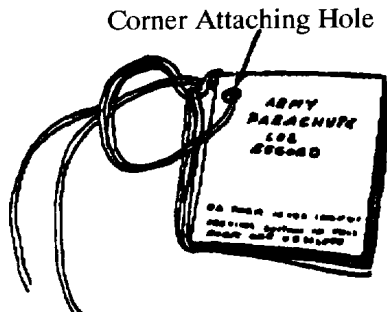
**Installing Attaching Tie.** Install attaching tie as follows:

1. Cut a 30-inch length of tape, lacing and tying waxed nylon thread (Item 28, WP 0125 00) and double the lacing length to form a 15-inch length, double strand.
2. Pass looped end of the double lacing length around the centerfold of the log record and form a slip loop on the outside at the log record top.



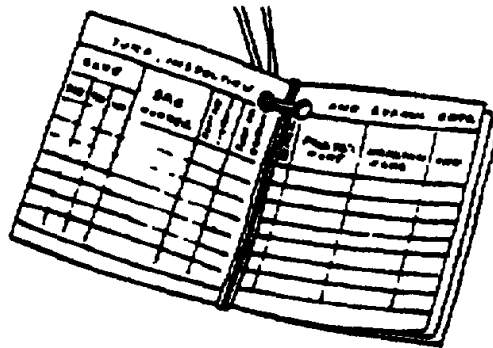
Forming Slip Loop On Log Record Outside

3. Pass lacing length running ends through the corner attaching hole from the front cover of log record book.



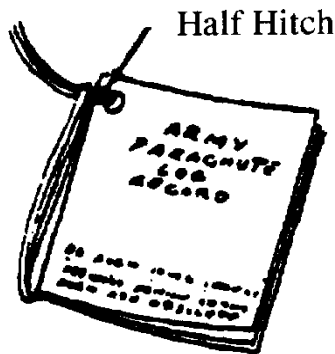
Passing Lacing Loose Ends Through Corner Attaching Hole

4. Ensure running ends are routed over that part of the lacing length located along the log record centerfold.



Routing Lacing Loose End Through Log Record Centerfold

5. Complete the attachment tie by making a half hitch on top of the slip loop made in step 2., above.
6. Attach the log record to the item at a convenient point.



Log Record Attachment Tie Completed

**Accomplishing a Log Record.** Upon completion of first technical/rigger-type inspection, the individual performing the inspection will initially prepare a log record for the item and accomplish subsequent record entries using the following procedures:

NOTE

Log record book entries will be made with a suitable type blue or black marking device that cannot be erased.

1. Inside front cover. Using the information provided on the item make the following entries on the inside front cover of the log record. Entries may be continued on the inside of the back cover, if necessary.

SERIAL NO.	<input type="checkbox"/>
TYPE	
PART NO.	
DATE OF MFG. (Month & Year)	
MANUFACTURER	
CANOPY CONTRACT NO.	
STATION & UNIT	
<i>(Continued on inside back cover)</i>	

- a. Serial number. Enter the item serial number.
  - b. Type. Enter the type of item.
  - c. Part number. Enter the part number of the item.
  - d. Date of Manufacture. Enter the month and year the item was manufactured.
  - e. Manufacturer. Enter the name of the manufacturer.
  - f. Canopy Contract Number. Enter the entire contract number specified for the item.
  - g. Station and Unit. Enter the name of the station and unit to which the item is currently assigned. When the item is transferred permanently to another station and/or unit, original entry will be lined out and the name of the receiving station and/or unit will be entered.
2. Inside Back Cover. Entries may be continued on the inside back cover, if necessary.

<input type="checkbox"/> STATION & UNIT (Continued)

3. Modification Work Order (MWO) Compliance Record Page. When a modification is performed on an item, the following entries will be made on the "Modification Work Order Compliance Record" pages of the Log Record.
  - a. MWO Number. Enter publication number and date of Modification Work Order (MWO) that describes MWO (Item 1, Illustration on following page).
  - b. MWO Title. Enter a short, abbreviated title extracted from the MWO prescribing the work.
  - c. Modified By. Enter the last name of the individual who has performed the modification. If the original log record for the item has been lost, and it has been ascertained through inspection that a particular modification has been accomplished, the entry for this column will be C/W, COMPLIED WITH (Item 2, Illustration below), which signifies the applicable MWO has been complied with.

Modification Work Order		Compliance Record					
MWO Number	MWO Title	Modified By (Name)	INSP By	UNIT	Date		
					Day	MO.	YR.
① 10-1670-296-20-1 15 MAY 95	MODIFY M-1 Release	VENCKUS	Nanos	HHO	15	6	95
② 10-1670-296-20-1 15 MAY 95	MODIFY M-1 RELEASE	C/W	Conel	Netick	18	6	95
10-1670-296-20-1 15 MAY 95	Modify M-1 Release	LAND	Galisto	ADPSD	21	6	95

1. Modification Work Order Compliance Completed.
2. Modification Completed By Unknown Due To Lost Original Log Record.

- d. Inspected By. The individual who accomplished the inspection required after modification will sign this entry with their last name only.
  - e. Unit. Enter the unit designation responsible for performing the MWO or in the event of a lost Log Record, the unit to which the inspector is assigned.
  - f. Date. Enter the date (day, month, and year) the modification work was completed.
4. Unit and Direct Support Repair and Inspection Data. When an item is initially received from a supply source and a technical/rigger-type inspection is performed, the inspection accomplishment will be documented on the "Unit and Intermediate Repair and Inspection Data" page of the individual Parachute Log Record. Additional entries will also be made on this page each time the item is repaired or is administered an inspection in compliance with a Maintenance Advisory Message (MAM) or Ground Precautionary Message (GPM). The page completion criteria is as follows:
    - a. Type of Repair. Enter the type of repair, completion of initial inspection, repair accomplishment, or MAM or GPM compliance.



- b. Inspection By. The individual who accomplished the inspection required will sign this entry with last name.
- c. Unit. Enter the unit designation responsible for performing the type of repair.
- d. Date. Enter the date (day, month and year) the repair was performed.

Unit & Direct Support		Repair & Inspection Data			
Type of Repair	Insp. By	Unit	Date		
			Day	MO	YR
1. Initial Inspection	Venckus	SBECON	12	2	01
2. 1 Sec and 4 Lines replaced	Gravel	SBECON	3	3	01
3. GPM 00-01	Burner	SBECON	10	4	01

- 1. Completion Of Initial Inspection.
- 2. Repair Accomplishment.
- 3. Technical Bulletin Inspection Compliance.

- 5. Note Page. A page is provided at the back of the parachute log record to accommodate recording of additional data pertinent to the serviceability them item. This shall also include the month and year the item was placed in service.

**NOTES**

RISER MFG DATE: JAN '86  
 PLACED IN SERVICE: MAR '86  
 IMMERSED IN SALT WATER: 26/10/86  
 RINSED 27/10/86

- 6. Jump, Inspection, and Repack Data Page. Beginning with the initial inspection of an item and each time the item is administered a routine inspection, make the applicable entries on the JUMP, INSPECTION, AND REPACK DATA page of the log record as follows:

JUMP, INSPECTION.				ROUTINE INSPECTION	AND REPACK DATA		
DATE			BAG NUMBER		REPACK	PACKER'S NAME	INSPECTOR'S NAME
DAY	MO.	YR.					
6	1	02	005439		IN Gravel	Venckus	

- a. Date. Enter the data (day, month, and year) of each inspection action applied to the item. These actions include the initial inspection and routine inspection.
- b. Routine Inspection. Enter a checkmark when an item is administered a routine inspection.
- c. Jumped or Dropped. No entry required.
- d. Packer's Name. The rigger performing the routine inspection, as applicable will sign this entry.
- e. Inspector's Name. The inspector who has performed the pack-in-process inspection or routine inspection, as applicable, will sign this entry.

**NOTE**

A parachute log record that is completely filled out, lost, illegible, or in an otherwise unserviceable condition, will be replaced with a serviceable log record.

7. Replacing a filled out or unserviceable log record.
  - a. Using a suitable blue or black marking device, enter NEW BOOK on the outside front cover of the replacement log record.
  - b. Transcribe the information from the inside front cover of the original log record to the inside front cover of the replacement log record. If the original data is illegible or missing, use the item information data block to collect the required data.
  - c. In the replacement log record; transcribe the initial and last entry made on the JUMP, INSPECTION, AND REPACK DATA page of the original log record.
  - d. Transcribe all data from the remaining pages of the original log record to the appropriate pages of the replacement log record.
  - e. After all original data has been transcribed, destroy the original log record.
8. Replacing a lost log record.

**NOTE**

Any time a log record is discovered missing from a an item, a replacement log record will be initiated during repack or inspection, as applicable.

- a. Using a suitable blue or black marking device, enter NEW BOOK at the top of the inside front cover of the replacement log record.
- b. Accomplish the log record inside front cover as detailed above.

- c. The age life of the item will be obtained from the date of manufacture or, if available, the date the item was placed into service as indicated on the item information data block. Enter the date placed in service (initial) and other applicable data on the JUMP, INSPECTION, AND REPACK DATA page of the log record as detailed above. Enter IN if date placed in service is known. If unknown, enter UNK.
- d. If it can be ascertained by inspection that a previous Modification Work Order (MWO) has been complied with, applicable entries will be made on the appropriate page of the replacement log record.
- e. Attach the replacement log record to the log record/inspection data pocket using the procedures detailed above.

**COMMON TOOLS AND EQUIPMENT**

For authorized common tools and equipment, refer to the Modified Table of Organization and Equipment (MTOE) and the Table of Distribution and Allowances (TDA) applicable to your unit. The common hand tools required for assembly and repair of the ancillary items are listed in WP 0064 00, Table 2., MAC, of this manual.

**SPECIAL TOOLS AND EQUIPMENT**

Common tools are listed in WP 0064 00, Table 2., of this manual. For special tools, see WP 0122 00 of this manual.

**REPAIR PARTS**

Repair parts are listed in WPs 0065 00 through 0121 00 of this manual.

**END OF WORK PACKAGE**



---

**ANCILLARY EQUIPMENT FOR LOW VELOCITY AIR DROP SYSTEMS (LVADS)  
PREVENTIVE MAINTENANCE CHECKS AND SERVICES (PMCS), INTRODUCTION**

---

**GENERAL**

The following describe PMCS procedures on the unit support levels. The PMCS table has been provided to ensure the ancillary equipment is in proper operating condition, and ready for its primary mission.

Be sure to perform your PMCS each time you use the equipment. Always do your PMCS in the same order, so it gets to be a habit. Once you've had some practice, you'll quickly spot anything wrong.

Do your BEFORE (B) PMCS just before you use the equipment. Pay attention to WARNINGS, CAUTIONS, and NOTES.

Do your DURING (D) PMCS while you use the equipment. During operation means to check the equipment and its related components while it is being used. Pay attention to WARNINGS, CAUTIONS and NOTES.

Do your AFTER (A) PMCS right after using the equipment. Pay attention to WARNINGS, CAUTIONS and NOTES.

Do your WEEKLY (W) PMCS once a week.

Do your MONTHLY (M) PMCS once a month.

Use DA Form 2404 (Equipment Inspection and Maintenance Worksheet) to record any faults that you discover before, during, or after operation, unless you can fix them. You DO NOT need to record faults that you fix.

**Frequency of Performing PMCS.** PMCS will be performed before equipment is rigged for use, during modification and repair, after use, or at any time deemed necessary by the air delivery equipment maintenance officer.

**PMCS Columnar Entries Table 1.** Enter data in columns as follows:

Item number. The item number column shall be used as a source of the item number required for the TM Number column on DA Form 2404 (Equipment Inspection and Maintenance Worksheet), when recording the results of the PMCS.

Interval. This column identifies the required PMCS interval.

Item to be inspected. Contains the common name of the item to be inspected.

Procedures. Provides a brief description of the procedures by which the checks are to be performed.

The items are listed consecutively and the numbers indicate the sequence of minimum inspection requirements. The types and intervals of inspection required for the platform are as follows:

Routine inspection: Before and after operation.

Technical/Rigger-type Inspection: Before rigging, and before and after maintenance.

**Item Number.** Item numbers (ITEM No.) shall be assigned to the PMCS procedures. The PMCS procedures shall be arranged in a logical sequence requiring minimum time and motion on the part of the person(s) performing them and shall be so arranged that there will be minimum interference between persons performing the checks simultaneously on the same end item.

**Intervals.** The designated interval (INTERVAL) (i.e., before, during, after, weekly, etc.) when each check is to be performed shall be included. Procedures done first or most frequently (i.e., "before" checks and services) shall appear prior to "during" and "after" checks and services. When more advantageous to the user intervals shall be sub-grouped by crewmembers(s).

**Item to be Checked or Serviced.** The items listed (ITEM TO BE CHECKED OR SERVICED) shall be identified in as few words as possible to clearly identify the item. Usually the common name (e.g. EFTC, 2-point link, clevis, etc.) will be enough.

**Procedures.** The procedure (PROCEDURE) by which each check is to be performed, as well as any information required to accomplish each check or service, including lubrication, appropriate tolerances, adjustment limits, and instrument gage readings shall be provided. Whenever replacement or repair is recommended, the maintenance task shall be included or the applicable maintenance instruction work package may be referenced.

### SCOPE

The following work packages (WP 0007 00 through WP 0060 00) contain maintenance procedures that are the responsibility of the specified technician, as authorized by the Maintenance Allocation Chart (MAC), and the Source, Maintenance, and Recoverability (SMR) coded items that are identified in the Repair Parts and Special Tools List (RPSTL).

### MAINTENANCE FUNCTIONS/PROCEDURES

Each of the mentioned work packages above identifies a maintenance function specified in the MAC. All maintenance procedures required to complete a maintenance function are identified under "This Task Covers:" in the order in which the work is most logically accomplished.

### LUBRICATION INTERVAL

Not applicable.

### CORROSION PREVENTION AND CONTROL (CPC)

Corrosion Prevention and Control (CPC) of Army materiel is a continuing concern. It is important that any corrosion problems with this item be reported so that the problem can be corrected and improvements can be made to prevent the problem in future items.

While corrosion is typically associated with rusting of metals, it can also include deterioration of other materials, such as rubber and plastic. Unusual cracking, softening, swelling, or breaking of these materials may be a corrosion problem.

If a corrosion problem is identified, it can be reported using Standard Form SF 368, Product Quality Deficiency Report. Use of keywords such as "corrosion," "rust," "deterioration," or "cracking" will ensure that the information is identified as a CPC problem. The form should be submitted to the address specified in DA PAM 738-750, Functional Users Manual for the Army Maintenance Management System (TAMMS).

**Equipment Not Ready/Available If.** A brief statement of the condition (EQUIPMENT NOT READY/AVAILABLE IF) (e.g., malfunction, shortage) that would cause the equipment to be less than fully ready to perform its assigned mission shall be provided.

**Recording Defects.** All defects discovered during the inspection will be recorded using the applicable specifics in DA Pamphlet 738-750.

**Inspection Function Requirement.** Normally, air delivery equipment maintenance personnel at a rigging activity will perform a technical/rigger-type inspection. The inspection of initial receipt items will be performed as a separate function from the rigging activity; the item to be inspected will be placed in a suitable sized floor area. Should defect or damage be discovered at any point during the inspection, the inspection will be terminated and the applicable item will be repaired.

Should defect or damage be discovered at any point during the inspection, the inspection will be terminated and the applicable item will be processed and forwarded to repair activity. The repair activity, in turn, will conduct a technical/rigger-type inspection that will be performed by only those parachute rigger personnel cited in AR 750-32.

## DROP TESTING PROCEDURES

### NOTE

Conducted only by authorized units.

Drop testing of airdrop equipment consists of physically air dropping an item from an aircraft in flight. The drop test proves the serviceability of an item or checks parachute rigger proficiency. It will be performed under the supervision of qualified parachute rigger personnel who satisfy the supervisory requirements outlined in AR 750-32. Drop-testing usually will be conducted by an activity responsible for the inspection and maintenance of airdrop equipment. The criteria required to accomplish a drop test is as follows:

**Weight and Conditions.** The weight of the test load will be proportional with the standard design load of the specific parachute being tested. The parachute will be released under conditions consistent with the requirements for an equipment drop.

**Monitoring.** During the drop-test of the LVADS, the deployment of the parachute will be thoroughly monitored and observed to detect any evidence of malfunction or defect. Enter a record of the drop-test into the applicable parachute log record as follows:

## CHECKS AND SERVICES

Table 1 contains a tabulated listing of organizational preventive maintenance checks and services, which must be performed by a qualified rigger.

**Common Checks to the LVADS Ancillary Equipment.** When you perform PMCS procedures, you will always need a rag or two.

1. Remove debris with a dry stiff bristle brush.
2. Remove dirt and grease with a soap solution composed of one-half cup of dishwashing detergent per gallon of water. Rinse with clean water. Wipe dry with a clean cloth.
3. Check equipment for rust and corrosion. If any bare metal or corrosion exists, clean, and apply a thin coat of oil, unless otherwise stated. Report it to your supervisor.
4. Check all bolts, nuts and screws for obvious looseness, missing, bent, or broken condition. Look for chipped paint, bare metal, or rust around bolts heads. If you find a bolt, nut or screw you think is loose, tighten it or report it to your supervisor.
5. On welded items, look for loose or chipped paint, rust, or gaps where parts are welded together. If you find a bad weld, report it to your supervisor.

**CLEANING AND DRYING**

Inspect LVADS Ancillary Equipment after each use for dampness, dirt, or foreign material. Cleaning and drying may be required to prevent a possible malfunction or deterioration of the item(s). Process equipment that has been immersed in water as given in WP 0007 00, INSPECTION, and WP 0009 00, SALT/FRESH-WATER CONTAMINATION TEST. Clean the equipment as follows:

**CAUTION**

If during the cleaning of LVADS Ancillary Equipment, there exists a possibility that a substance to be removed contains acid, the item will be condemned.

**Cleaning.** The cleaning of airdrop equipment will be held to a minimum and performed only when it is necessary to eliminate a malfunction potential or the possibility of material deterioration. The cleaning method must be compatible with the type of material to be cleaned and the nature of the substance to be removed. Clean LVADS Ancillary Equipment using the following procedures:

**Shaking and Brushing.** Clean most LVADS Ancillary Equipment assemblies by shaking or gently brushing with a dry soft-bristle brush. A dry stiff-bristle brush can be used on items made of canvas, metal, or wood.

**Spot-cleaning.** Spot-clean soiled areas on a fabric airdrop item that cannot be cleaned by shaking or brushing as follows:

**CAUTION**

When rinsing the equipment, do not attempt to wring the equipment fabric or lines.

**Cotton Items**

1. Spot-clean a cotton item by rubbing the soiled area with a clean cloth and a solution composed of one-half cup of hand dishwashing detergent (liquid or powdered) dissolved in one gallon of warm water.
2. Once the foreign substance has been removed, rinse the cleaned area by repeating the rubbing process with clean portion of the cloth that has been dampened with fresh clean water.
3. Do not wring out the rinsed area.
4. Allow the applicable item to dry thoroughly.

**Nylon and Rayon Items**

1. A soiled nylon or rayon item may be spot cleaned using the cleaning procedures detailed above.
2. A soiled area cleaned with the soap and water solution will be rinsed with fresh, clean water and allowed to dry thoroughly.
3. Do not attempt to wring out the material that has been cleaned and rinsed.



**Plastic and Wood Items**

1. Spot cleaning of a plastic or wood item will be accomplished by using procedures from the Spot-cleaning paragraph detailed on the previous page, as required.
2. Imperfections on plastic items may be removed by buffing with crocus cloth. Similar defects on wood items can be fixed with a suitable grade of sandpaper.
3. When applicable, ensure that any adjacent fabric is not damaged when buffing or sanding.

**Metal Items**

1. Remove any burrs, rough spots, rust, or corrosion on metal items that cannot be eliminated by brushing or spot cleaning (Shaking and Brushing paragraph and Spot-cleaning paragraph detailed on the previous page) by buffing and polishing with crocus cloth or steel wool. Ensure that any adjacent materials are not harmed when filing, buffing, or polishing.
2. When the metal item has been properly smoothed, remove all oils and filings by brushing and dipping in a soap and water solution.
3. When dried, spray the metal item with a dry film lubricant and allow to air dry for 24-hours and put the item back into service.
4. Shield any adjacent fabric when spraying dry film lubricant to prevent saturation.
5. Small amounts of lubricant will not damage fabric, but may cause discoloration and make fabric appear soiled.

**Drying**

1. Suspend or elevate wet or damp LVADS Ancillary Equipment in a well-ventilated room or in a heated drying room.
2. Item drying time may be reduced through the use of electric circulating fans.
3. When heat is used, the temperature will not be higher than 160°F (71.5°C), with a preferred temperature at 140°F (60.0°C) until the item is dry.
4. Fabric or wooden items will not be dried in direct sunlight by laying an item out on the ground, except in an emergency.

**CLEANING AGENTS****WARNING**

DO NOT use diesel fuel, gasoline, or benzene (benzol) for cleaning.

**NOTE**

All PMCS inspections will be a Technical/Rigger Inspection.

**END OF WORK PACKAGE**



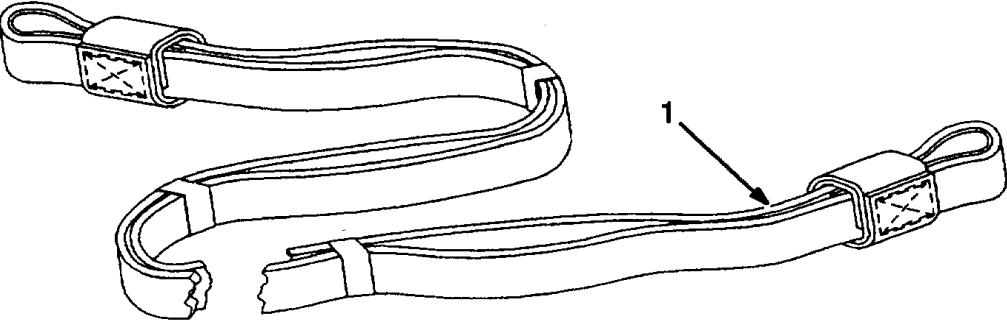
**ANCILLARY EQUIPMENT FOR LOW VELOCITY AIR DROP SYSTEMS (LVADS)  
PREVENTIVE MAINTENANCE CHECKS AND SERVICES (PMCS)  
BEFORE PROCEDURES**

**NOTE**

All PMCS inspections will be a Technical/Rigger Inspection.

**Table 1. Preventive Maintenance Checks and Services**

ITEM NO.	INTERVAL			ITEM TO BE CHECKED OR SERVICED	EQUIPMENT NOT READY/ AVAILABLE IF:
	B	D	A		
1	•			<b>Multi-Loop Line.</b> Inspect multi-loop line (1) for lose or broken stitching, cuts, worn or frayed webbing and presence of foreign matter. Refer to WP 0012 00.	Multi-loop line has loose or broken stitching, cuts, worn or frayed webbing, or foreign matter present.



The diagram shows a multi-loop line, which is a long, flat webbing strap with multiple loops. One end has a buckle. A callout '1' with an arrow points to a specific section of the webbing, likely indicating the area to be inspected for damage as described in the table.

Table 1. Preventive Maintenance Checks and Services - continued

B – Before

D – During

A – After

ITEM NO.	INTERVAL			ITEM TO BE CHECKED OR SERVICED	EQUIPMENT NOT READY/ AVAILABLE IF:
	B	D	A		
2	•			<p><b>Extraction Force Transfer Coupling.</b> Ensure that all parts are present and securely fastened together. Check for a bent Spring Guide Rod, check for free movement of actuator arm latching pin, ensure the three (3) self locking nuts on 3-point link assembly are tight, check for a misaligned dot and arrow, ensure cam of 3-point link and latch are properly seated, check EFTC for positive lock and operation. Inspect extraction force transfer coupling (1) for presence of foreign matter. Refer to WP 0013 00.</p>	<p>Extraction force transfer coupling (1) is not complete, spring guide rod shows bending or a curvature against a straight edge, latch pin is bent, sticks in one position, binds, is dirty, or debris is found in the latch pin assembly inside actuator, threads of bolts do not protrude from self locking nuts by two (2) threads or are at least flush with the three self locking nuts, dot and arrow are not aligned within a <math>\frac{1}{16}</math>-inch but lock link is fully seated into catch slot, extraction force has foreign matter present.</p>

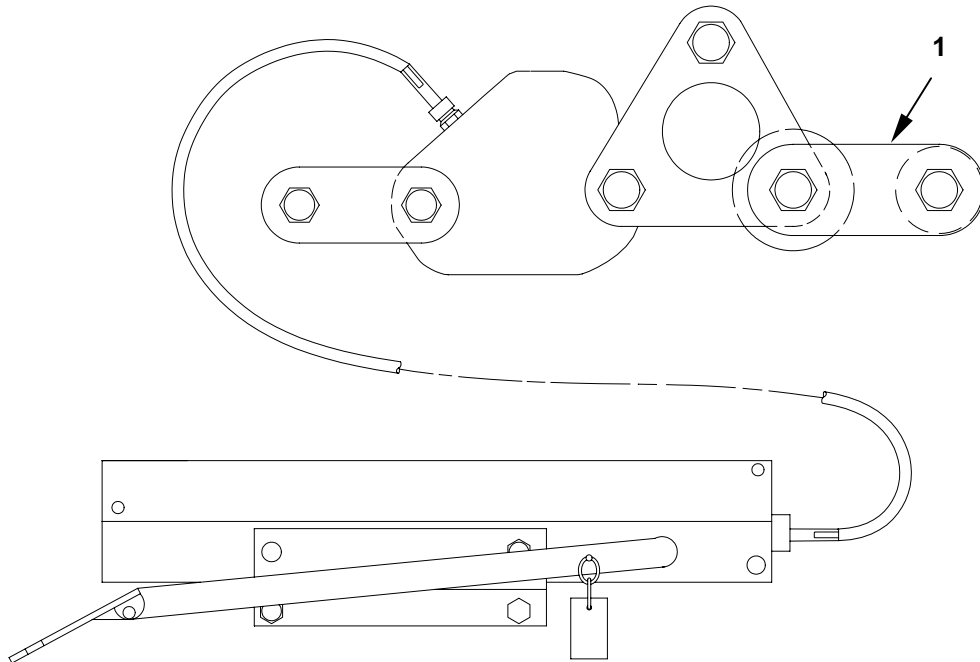


Table 1. Preventive Maintenance Checks and Services - continued

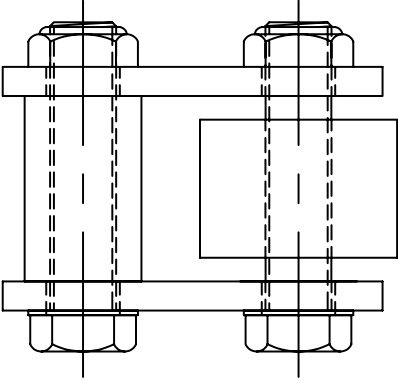
ITEM NO.	INTERVAL			ITEM TO BE CHECKED OR SERVICED	EQUIPMENT NOT READY/ AVAILABLE IF:
	B	D	A		
3	•			<p><b>EFTC Link Adapter Assembly.</b> Inspect link assembly adapter (1) for rough areas, bends, or cracks. Ensure that threads (2) are not stripped or damaged. Refer to WP 0014 00.</p>	<p>Link assembly adapter (1) has rough areas, bends, or cracks. Threads (2) are stripped.</p>
					
4	•			<p><b>EFTC 3- Point Link Adapter Assembly.</b> Check each link assembly (three point) for proper parts and assembly.</p> <p>Check assembly (1) operation. Inspect for excessive wear, bends, breaks, or weld separation.</p> <p>Check for proper orientation of the cam with the extraction and deployment line for the load.</p> <p><b>NOTE</b> The cam may be reoriented by loosening the locking nut, removing the pin and reinserting the cam in the desired orientation.</p>	<p>Assembly (1) is inoperable or has excessive wear, bends, breaks, or weld separation.</p> <p>Cam does not rotate freely. Cam does not properly engage with an open latch assembly, dot and arrow are misaligned.</p>

Table 1. Preventive Maintenance Checks and Services - continued

B – Before

D – During

A – After

ITEM NO.	INTERVAL			ITEM TO BE CHECKED OR SERVICED	EQUIPMENT NOT READY/ AVAILABLE IF:
	B	D	A		
4 - continued	•			<p><b>EFTC 3- Point Link Adapter Assembly.</b> Ensure the locking nuts securing the three-point link are properly adjusted to allow the cam to rotate freely.</p> <p>Tighten the three-point link assembly locking nuts fully and back off one half turn so the cam and spools rotate freely.</p> <p>Check for the proper engagement of the cam with an open latch assembly. The cam must fit without interference and seat properly into the latch assembly when the latch is manually relocked and the dot and arrow are aligned.</p> <p style="text-align: center;"><b>NOTE</b></p> <p>If different cams are tried and none will engage and seat properly in the latch, the latch shall be tagged “defective-latch” and set aside. Refer to WP 0015 00.</p>	See previous.

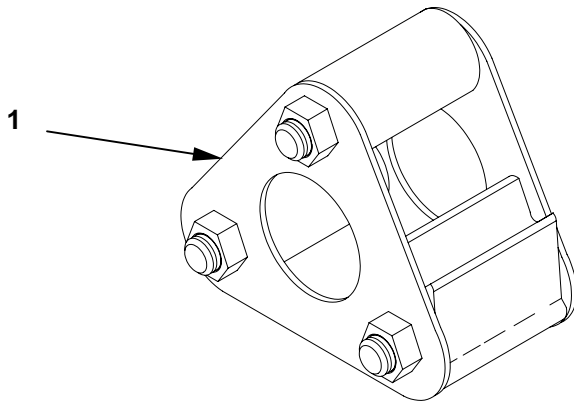


Table 1. Preventive Maintenance Checks and Services - continued

ITEM NO.	INTERVAL			ITEM TO BE CHECKED OR SERVICED	EQUIPMENT NOT READY/ AVAILABLE IF:
	B	D	A		
5	•			<p><b>EFTC Latch Assembly.</b>                      Inspect latch assembly coupling for rough areas, bends, cracks, or foreign material. Check for any loose pins in the latch assembly and re-stake if necessary.</p> <p>All latch assemblies must be checked prior to every airdrop. Visually inspect if the ½-inch diameter pins in latch side plates, that secure retainer and catch are separate pins or if they are integral fixed pins optional one-piece construction. If the retainer and catch are one-piece construction, staking is not necessary. If they are not, check for loose pins on the retainer catch and lock link as follows:</p> <ol style="list-style-type: none"> <li>Using a flat surface 3/8-inch diameter (or less) pin or bolt, tap gently with a hammer on each end of the ½-inch diameter latch pin.</li> <li>If the pins are loose and can fall through the side plates re-stake pins by obtaining a hardened (50 Rockwell C hardness or higher) center punch.</li> <li>Place the assembled latch on a solid level surface and place tip of punch approximately 1/16-inch from the edge of the ½-inch diameter hole in the side plates.</li> </ol>	<p>Latch assembly coupling has rough areas, bends, or cracks, or foreign material is present, ½-inch diameter pins in latch side plates are loose, upper retainer nut not flush with the latch assembly housing, retainer hook (1) does not release when the latch assembly adapter is activated, dot and arrow marking misalignment, loose pins in the latch assembly.</p>

Table 1. Preventive Maintenance Checks and Services - continued

B – Before

D – During

A – After

ITEM NO.	INTERVAL			ITEM TO BE CHECKED OR SERVICED	EQUIPMENT NOT READY/ AVAILABLE IF:
	B	D	A		
5 - continued	•			<p>4. Strike punch with a hammer to cause <math>\frac{3}{32}</math>-inch dimple and slight flow of metal towards the inside edge of the hole which will then retain the latch.</p> <p>5. Repeat the stacking at four places (90 degrees apart from each latch pin).</p> <p>Re-check for loose pins as described above. Check that the retainer hook releases when the latch assembly adapter is activated.</p> <p>Inspect latch assembly and identify "dot and arrow" marking misalignment. Ensure upper retainer nut is tight and flush with the latch assembly housing.</p> <p>Manually operate the latch in accordance with FM 4.20-102 (10-500-2)/TO 13C7-1-5. Apply thumb pressure on the catch to overcome the spring pressure and lift up the catch.</p> <p>Collapse the linkage manually by pushing down on top of retainer hook end. Latch shall relock manually with dot and arrow aligned. Refer to WP 0017 00.</p>	See previous page.

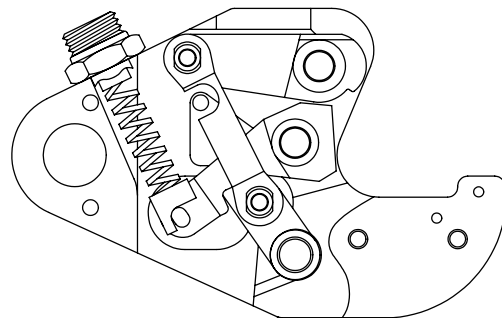
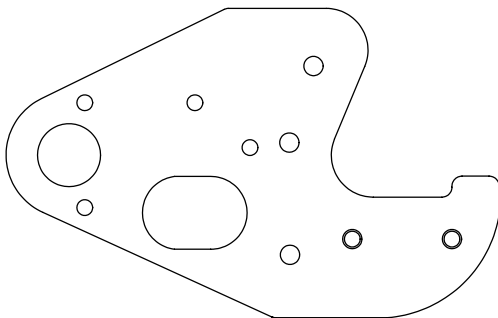




Table 1. Preventive Maintenance Checks and Services - continued

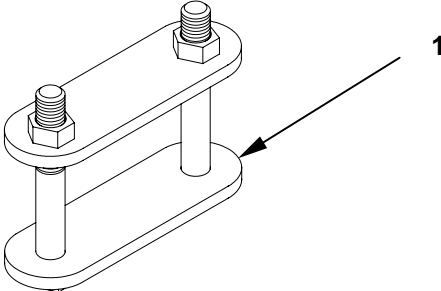
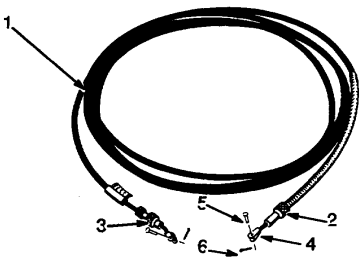
ITEM NO.	B – Before			D – During	A – After
	INTERVAL			ITEM TO BE CHECKED OR SERVICED	EQUIPMENT NOT READY/ AVAILABLE IF:
	B	D	A		
6	•			<p><b>Latch Connector Assembly.</b> Inspect latch connector assembly (1) for rough areas, bends, or cracks. Ensure that threads are not stripped or damaged. Refer to WP 0016 00.</p>	<p>Latch assembly connector has rough areas, bends or cracks, or foreign material is present.</p>
					
7	•			<p><b>EFTC Cable Assembly.</b> Inspect cables prior to every drop by extending the cable straight. Check for free movement of inner cable by separately pulling on each cable. Inspect both ends of inner cable for birdcage effect or damage. Inspect cable (1) for bends or kinks. Check that cable moves freely within its cover. Ensure that cable's cover is not broken, that the terminals (2) operate properly. Ensure that the adjusting collar set screws (3) is tight. Inspect yokes (4) for rough areas, bends, or cracks. Ensure that shank pins (5) and cotter pins (6) are present. Refer to WP 0018 00.</p>	<p>When measured with spring scale, manual force exceeds 10-lbs. Birdcage effect is present or damage to inner cable is evident. Cable (1) has bends or kinks. Cable does not move freely within its cover. Cable's cover is broken or damaged. Terminals (2) do not operate properly. Adjusting collar set screws (3) is loose. Yokes (4) have rough areas, bends, or cracks. Shank pins (5) or cotter pins (6) are missing.</p>
					

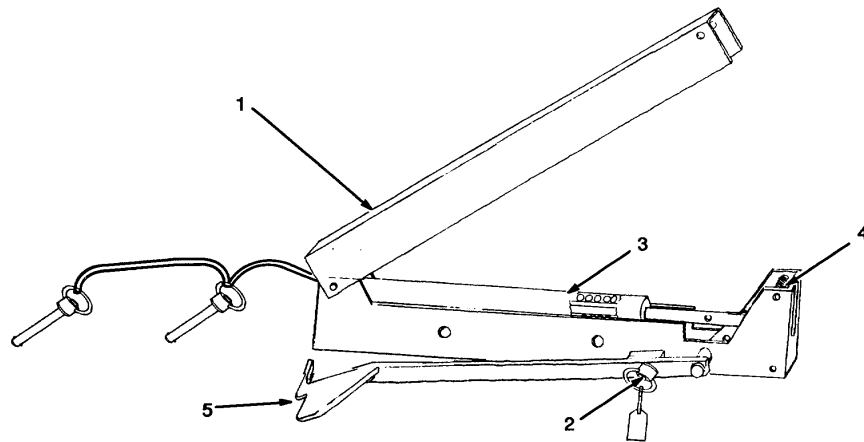
Table 1. Preventive Maintenance Checks and Services - continued

B – Before

D – During

A – After

ITEM NO.	INTERVAL			ITEM TO BE CHECKED OR SERVICED	EQUIPMENT NOT READY/ AVAILABLE IF:
	B	D	A		
8	•			<p><b>EFTC Actuator Assembly.</b> All actuator assemblies must be checked prior to every airdrop. Check assembly (1) operation. Inspect for excessive wear, bends, breaks, or weld separation. Check that safety pin (2) and the cam arm spring (3) are present. Ensure the axle nut (4) is not loose, the actuator arm (5) is not bent, and there is not excessive play between arm and axle. Rotate the arm to the locked position and insert the locking pin to safety the arm. Measure the distance from the center on the cable-connecting hole to the outside surface of the housing slot where the cable extends through. If the distance measures 2 ½-inches or more, the actuator arm or actuator link is defective and will not allow proper cable movement. If the distance is less than 2 ½-inches, the actuator is acceptable. Check the actuator by carefully removing the locking pin and slowly rotating the arm manually and confirm the arm will lock in the horizontal position under the action of the spring lever. Refer to WP 0019 00.</p>	<p>Assembly (1) is inoperable or has excessive wear, bends, breaks, or weld separation. Safety pin (2) and cam arm spring (3) are missing. Actuator arm (5) is bent, the axle nut (4) is loose, or there is excessive play between arm and axle. Distance measured is 2 ½-inches or more, the arm will not lock in the horizontal position under the action of the spring lever.</p>



**Table 1. Preventive Maintenance Checks and Services - continued**

**B – Before**

**D – During**

**A – After**

ITEM NO.	INTERVAL			ITEM TO BE CHECKED OR SERVICED	EQUIPMENT NOT READY/ AVAILABLE IF:
	B	D	A		
9	•			<p><b>M-1 Cargo Parachute Release.</b>                      Check release (1) operation. Ensure that, when using a 15-second timer, it activates within 12 and 16-seconds. Check for excessive wear or foreign material. Refer to WP 0020 00.</p>	<p>Release (1) does not operate properly. Timer is not accurate. Release is worn or has foreign material present.</p>

**NOTE**

The original Face Plate Bolts, NSN 5306-00-207-8362/Part Number AN6-25A has been temporarily replaced by NSN 5306-00-638-5821/Part Number AN6H-25A (H denotes a hole drilled in the bolt head). Either bolt is acceptable until the original bolt is brought back into the inventory.

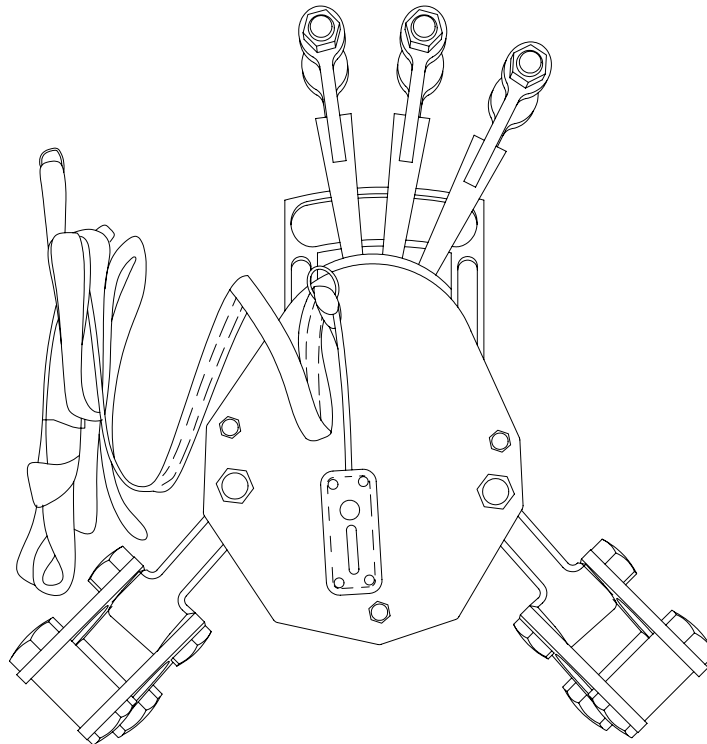


Table 1. Preventive Maintenance Checks and Services – continued

B – Before

D – During

A – After

ITEM NO.	INTERVAL			ITEM TO BE CHECKED OR SERVICED	EQUIPMENT NOT READY/ AVAILABLE IF:
	B	D	A		
10	•			<p><b>Lanyard Arming Wire.</b>                      Inspect lanyard (1) for loose or broken stitching, cuts, worn or frayed webbing, and presence of foreign matter. Inspect reworked arming wire lanyards by insuring the safety tie (type I ¼-inch cotton webbing) is properly routed and secured. Reworked arming wire lanyards can be identified by four small identification marks located around the circumference of the copper crimping sleeve, in addition, both ends should be flared. Refer to WP 0020 00.</p> <p>Verify length of lanyard. If necessary, fabricate a 25-foot lanyard for the M-2 Release IAW WP 0021 00.</p>	<p>Lanyard (1) has loose or broken stitching, cuts, or worn or frayed webbing, or foreign material is present. Safety tie is misrouted, improperly tied or secured with of the wrong material. Four small identification marks are not present or flared ends.</p>

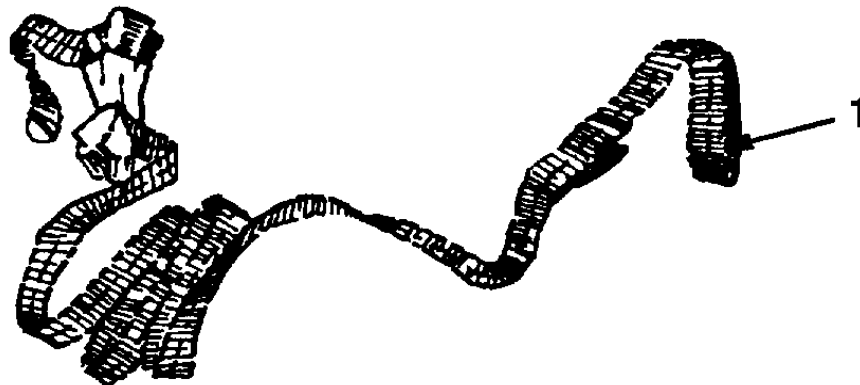


Table 1. Preventive Maintenance Checks and Services – continued

ITEM NO.	B – Before			D – During	A – After
	INTERVAL			ITEM TO BE CHECKED OR SERVICED	EQUIPMENT NOT READY/ AVAILABLE IF:
	B	D	A		
11	•			<p><b>Parachute Connector.</b> Inspect connector (1) for bends, cracks, burrs, and rough areas. Check if threads are stripped or cracked. Check if arms (2) engage into the retaining clamp. Refer to WP 0022 00.</p>	<p>Connector (1) has bends, burrs, or rough areas. Threads are stripped or cracked. Arms (2) do not engage into the retaining clamp.</p>
12	•			<p><b>Timer Delay Assembly.</b> Inspect timer assembly (1) for bends, cracks, burrs, rough areas, and foreign material. Verify any timer delay assemblies under CAGEC Code 3N257. If found, refer to WP 0023 00. Check if timer activates at the appropriate time and if stem (2) rotates freely in mounting block. Ensure that keys (3) retract at the end of time sequence. Refer to WP 0023 00.</p>	<p>Timer assembly (1) has bends, cracks, burrs, or rough areas or foreign material is present. Timer delay assembly is identified under CAGEC Code 3N257. Timer does not activate at the appropriate time or stem (2) does not rotate freely in mounting block. Keys (3) do not retract at the end of timing sequence.</p>

Table 1. Preventive Maintenance Checks and Services – continued

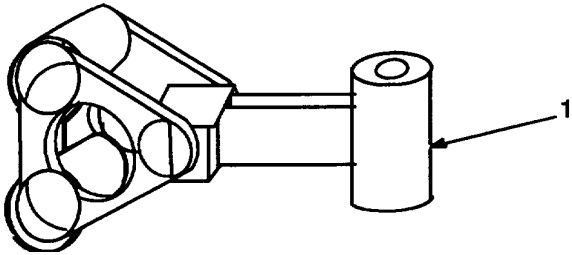
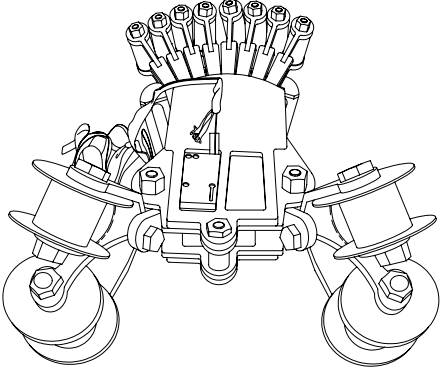
ITEM NO.	B – Before			D – During	A – After
	INTERVAL			ITEM TO BE CHECKED OR SERVICED	EQUIPMENT NOT READY/ AVAILABLE IF:
	B	D	A		
13	•			<p><b>Lower Link Suspension.</b> Inspect link (1) for bends, breaks, cracks, burrs, and rough areas. Check for stripped or damaged threads. Refer to WP 0020 00.</p>	<p>Link (1) has bends, breaks, or cracks. Surfaces have burrs or rough areas. Threads are stripped or damaged.</p>
					
14	•			<p><b>M-2 Cargo Parachute Release (42,000-lbs).</b> Check release (1) operation. Ensure that, when using a 15-second timer, it activates within 12- and 16-seconds. Check for excessive wear or foreign material. Check lanyard (2) for frayed material, cuts, and loose or broken stitching. Check to ensure free rotation of the lower suspension links. Refer to WP 0021 00.</p>	<p>Release (1) does not operate properly. Timer is not accurate. Release is worn or has foreign material present. Lower suspension links do not rotate freely.</p>
					

Table 1. Preventive Maintenance Checks and Services – continued

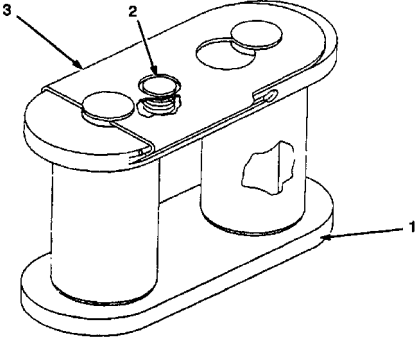
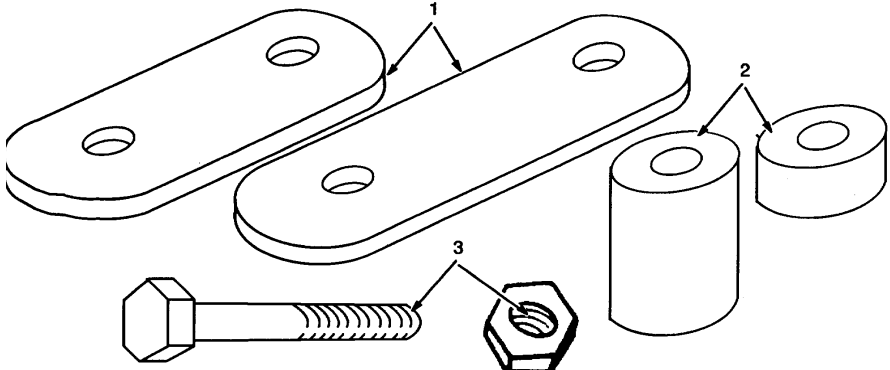
ITEM NO.	B – Before			D – During	A – After
	INTERVAL			ITEM TO BE CHECKED OR SERVICED	EQUIPMENT NOT READY/ AVAILABLE IF:
	B	D	A		
15	•			<p><b>Type IV Single Suspension Link Assembly.</b> Inspect link (1) for bends, breaks, cracks, burrs, or rough areas. Ensure proper operation of button (2) and lock (3). Refer to WP 0024 00.</p>	<p>Link (1) has bends, breaks, or cracks. Surfaces have burrs or rough areas. Button (2) or lock (3) does not function properly.</p>
<p><b>NOTE</b> No longer authorized for LVAD after 31 December 2003.</p> 					
16	•			<p><b>Heavy-Duty Link Assembly.</b> Inspect plates (1) and spacers (2) for rough areas, bends, breaks, or cracks. Ensure that threads (3) are not stripped or damaged. Refer to WP 0025 00.</p>	<p>Plate (1) or spacer (2) has rough areas, bends, breaks, or cracks. Threads (3) are damaged or stripped.</p>
					

Table 1. Preventive Maintenance Checks and Services – continued

ITEM NO.	INTERVAL			ITEM TO BE CHECKED OR SERVICED	EQUIPMENT NOT READY/ AVAILABLE IF:
	B	D	A		
17	•			<b>4-Point Link.</b> Inspect four-point link (1) for rough areas, bends, breaks, and cracks. Ensure fastener threads (2) are not stripped or damaged. Refer to WP 0026 00.	Link (1) has rough areas, bends, breaks, and cracks. Fasteners have stripped or damaged threads (2).
18	•			<b>Type IV Cover Link.</b> Inspect cover (1) for loose or broken stitches, tears, damaged cord (2), or foreign material. Refer to WP 0027 00.	Cover has loose or broken stitches, tears, damaged cord (2), or foreign matter present.
<p><b>NOTE</b> No longer authorized for LVAD after 31 December 2003.</p>					



Table 1. Preventive Maintenance Checks and Services – continued

ITEM NO.	B – Before			D – During	A – After
	INTERVAL			ITEM TO BE CHECKED OR SERVICED	EQUIPMENT NOT READY/ AVAILABLE IF:
	B	D	A		
19	•			<b>Aerial Delivery Clevis.</b> Inspect clevis (1) for rough areas, bends, breaks, and cracks. Ensure fastener threads (2) are not stripped or damaged. Refer to WP 0028 00.	Clevis (1) has rough areas, bends, breaks, and cracks. Fasteners have stripped or damaged threads (2).
20	•			<b>Clevis Cover.</b> Inspect cover (1) for loose or broken stitches, tears, broken grommets (2), or foreign material. Refer to WP 0029 00.	Cover (1) has loose or broken stitches, tears, broken grommets (2) are broken, or foreign material is present.

Table 1. Preventive Maintenance Checks and Services – continued

ITEM NO.	B – Before			D – During	A – After
	INTERVAL			ITEM TO BE CHECKED OR SERVICED	EQUIPMENT NOT READY/ AVAILABLE IF:
	B	D	A		
21	•			<p><b>Single Knife Parachute Release Strap.</b> Inspect strap (1) for loose or broken stitching, cuts, worn and frayed webbing, or presence of foreign material. Check knife (2) and fastener (3) for rough areas, bends, breaks, and cracks. Check knife edge (4) for sharpness. Ensure that ferrule (5) operates properly. Refer to WP 0030 00.</p>	<p>Strap (1) has loose or broken stitching, cuts, worn or frayed webbing, or foreign material is present. Knife (2) or fastener (3) has rough areas, bends, breaks, or cracks. Knife edge (4) is dull. Ferrule (5) does not cover the safety aperture (6) when unscrewed to the full open position.</p>
22	•			<p><b>Multi-Knife Parachute Release Strap.</b> Inspect strap (1) for loose or broken stitching, cuts, worn and frayed webbing, or presence of foreign material. Check knives (2) for rough areas, bends, breaks and cracks, and knife edges (3) for sharpness. Ensure that ferrules (4) operate properly. Refer to WP 0031 00.</p>	<p>Strap (1) has loose or broken stitching, cuts, worn or frayed webbing, or foreign material is present. A knife (2) has rough areas, bends, breaks, or cracks or its edge (3) is dull. A ferrule (4) does not cover the safety aperture (5) when unscrewed to the full open position.</p>

Table 1. Preventive Maintenance Checks and Services – continued

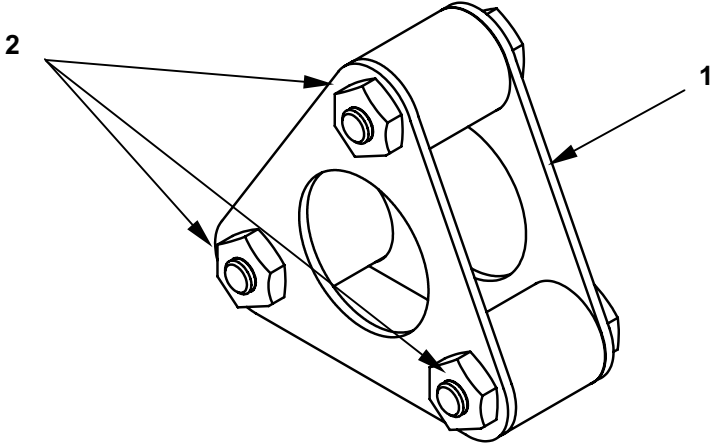
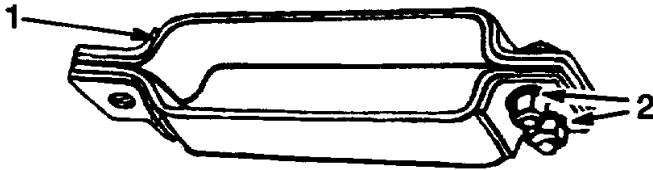
ITEM NO.	B – Before			D – During	A – After
	INTERVAL			ITEM TO BE CHECKED OR SERVICED	EQUIPMENT NOT READY/ AVAILABLE IF:
	B	D	A		
23	•			<p><b>3-Point Coupling Link Assembly.</b> Inspect three-point link (1) for rough areas, bends, breaks, and cracks. Ensure fastener threads (2) are not stripped or damaged. Refer to WP 0032 00.</p>	<p>Link (1) has rough areas, bends, breaks, and cracks. Fasteners have stripped or damaged threads (2).</p>
					
24	•			<p><b>M-35 Suspension Bracket.</b> Inspect bracket (1) for rough areas, bends, breaks, and cracks. Ensure fastener threads (2) are not stripped or damaged. Refer to WP 0033 00.</p>	<p>Bracket (1) has rough areas, bends, breaks, and cracks. Fasteners have stripped or damaged threads (2).</p>
					

Table 1. Preventive Maintenance Checks and Services – continued

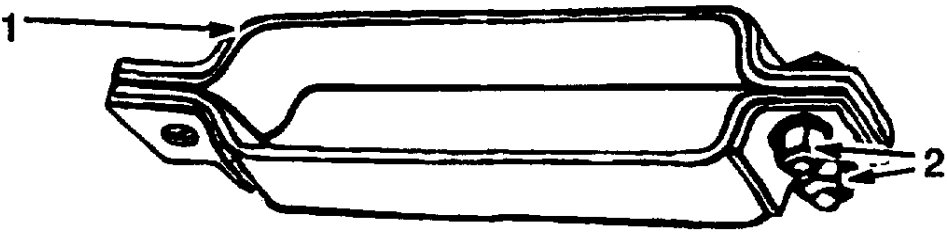
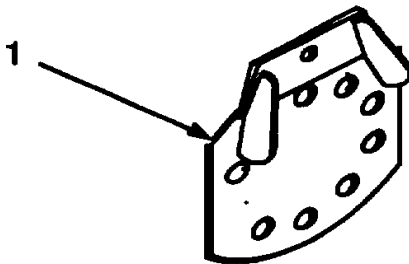
ITEM NO.	B – Before			D – During	A – After
	INTERVAL			ITEM TO BE CHECKED OR SERVICED	EQUIPMENT NOT READY/ AVAILABLE IF:
	B	D	A		
25	•			<p><b>M-59 Suspension Bracket.</b> Inspect bracket (1) for rough areas, bends, breaks, and cracks. Ensure fastener threads (2) are not stripped or damaged. Refer to WP 0034 00.</p>	<p>Bracket (1) has rough areas, bends, breaks, and cracks. Fasteners have stripped or damaged threads (2).</p>
					
26	•			<p><b>Suspension Plate.</b> Inspect plate (1) for rough areas, bends, breaks and cracks. Refer to WP 0035 00.</p>	<p>Plate (1) has rough areas, bends, breaks, and cracks.</p>
					

Table 1. Preventive Maintenance Checks and Services – continued

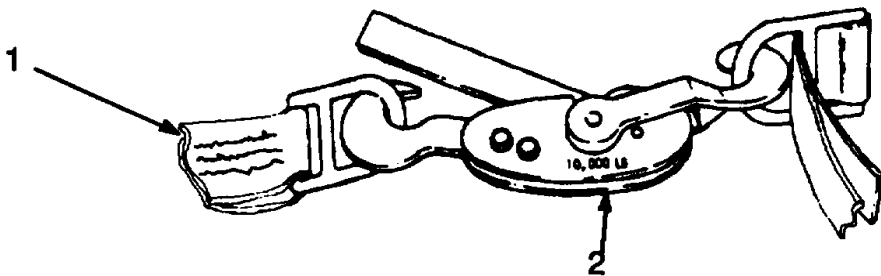
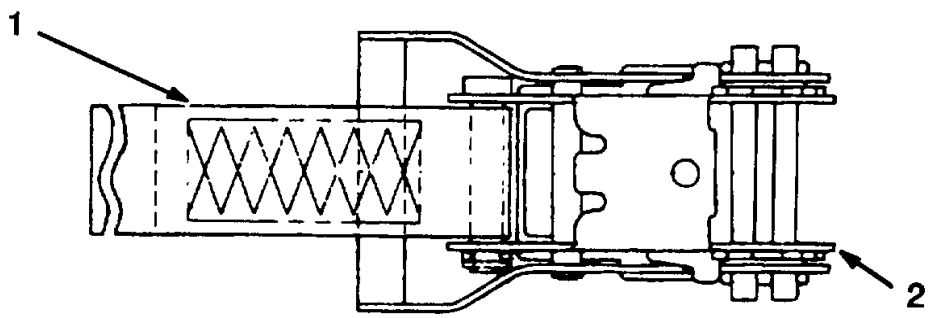
ITEM NO.	B – Before			D – During	A – After
	INTERVAL			ITEM TO BE CHECKED OR SERVICED	EQUIPMENT NOT READY/ AVAILABLE IF:
	B	D	A		
27	•			<b>10K Cargo Tie-down.</b> Inspect tie-down (1) loose or broken stitching, frayed webbing, foreign material, or a defective binder (2). Refer to WP 0036 00.	Tie-down (1) has loose or broken stitching or frayed webbing, foreign material is present, or the binder (2) is defective.
					
28	•			<b>Quick Release Cargo Tie-down.</b> Inspect tie-down (1) loose or broken stitching, frayed webbing, foreign material, or a defective quick-release lever (2). Refer to WP 0037 00.	Tie-down (1) has loose or broken stitching or frayed webbing, foreign material is present, or the quick-release lever (2) is defective.
					

Table 1. Preventive Maintenance Checks and Services – continued

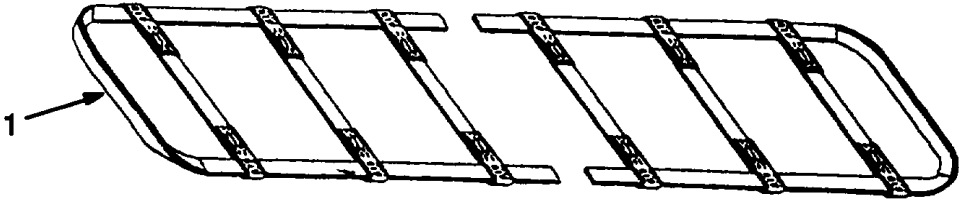
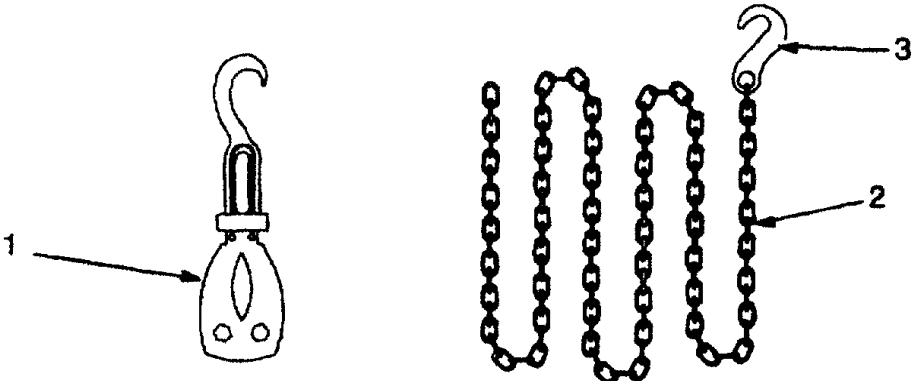
ITEM NO.	B – Before			D – During	A – After
	INTERVAL			ITEM TO BE CHECKED OR SERVICED	EQUIPMENT NOT READY/ AVAILABLE IF:
	B	D	A		
29	•			<p><b>Type IV Drive-Off Aid.</b> Inspect drive-off aid (1) for loose or broken stitching, frayed webbing, or foreign material. Refer to WP 0038 00.</p>	<p>Drive-off aid has loose or broken stitching or frayed webbing. Foreign material is present.</p>
					
30	•			<p><b>Aircraft Cargo Tie-down.</b> Inspect tie-down chain (1) for weak links, rough areas, bends, breaks, cracks, rust, or foreign material. Ensure turnbuckle threads (2) are not stripped or damaged. Refer to WP 0039 00.</p>	<p>Tie-down chain (1) has weak links, rough areas, bends, breaks, or cracks. Rust, or foreign material is present. Turnbuckle threads are stripped or damaged.</p>
					

Table 1. Preventive Maintenance Checks and Services – continued

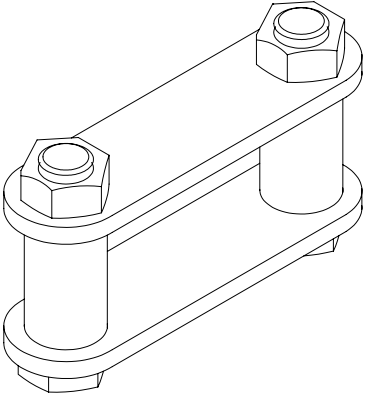
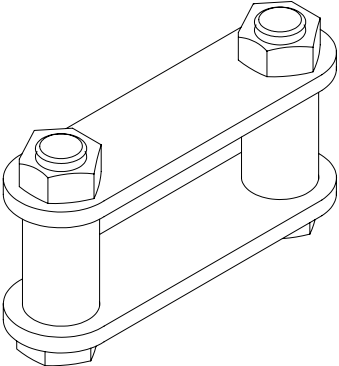
ITEM NO.	B – Before			D – During	A – After
	INTERVAL			ITEM TO BE CHECKED OR SERVICED	EQUIPMENT NOT READY/ AVAILABLE IF:
	B	D	A		
31	•			<p><b>3 ¾-Inch, 2-Point Link.</b>                      Inspect plates (1) and spacers (2) for rough areas, bends, breaks, or cracks. Ensure that threads (3) are not stripped or damaged. Refer to WP 0040 00.</p>	<p>Plate (1) or spacer (2) has rough areas, bends, breaks, or cracks. Threads (3) are damaged or stripped.</p>
					
32	•			<p><b>5 ½-Inch, 2-Point Link.</b>                      Inspect plates (1) and spacers (2) for rough areas, bends, breaks, or cracks. Ensure that threads (3) are not stripped or damaged. Refer to WP 0041 00.</p>	<p>Plate (1) or spacer (2) has rough areas, bends, breaks, or cracks. Threads (3) are damaged or stripped.</p>
					

Table 1. Preventive Maintenance Checks and Services – continued

ITEM NO.	B – Before			D – During	A – After
	INTERVAL			ITEM TO BE CHECKED OR SERVICED	EQUIPMENT NOT READY/ AVAILABLE IF:
	B	D	A		
33	•			<p><b>Release Away Static Line Assembly.</b> Check for loose or broken stitches. Inspect for frays, burns cuts or tears in webbing and sleeve. Check for loose or broken stitches, as well as missing or damaged hardware (grommets, 1-inch connector link). Ensure release line can move freely and there are no visible twists. Refer to WP 0042 00.</p>	<p>Static line has loose or broken stitching or frayed or cut webbing, damaged or missing hardware. Release does not move freely or is twisted.</p>

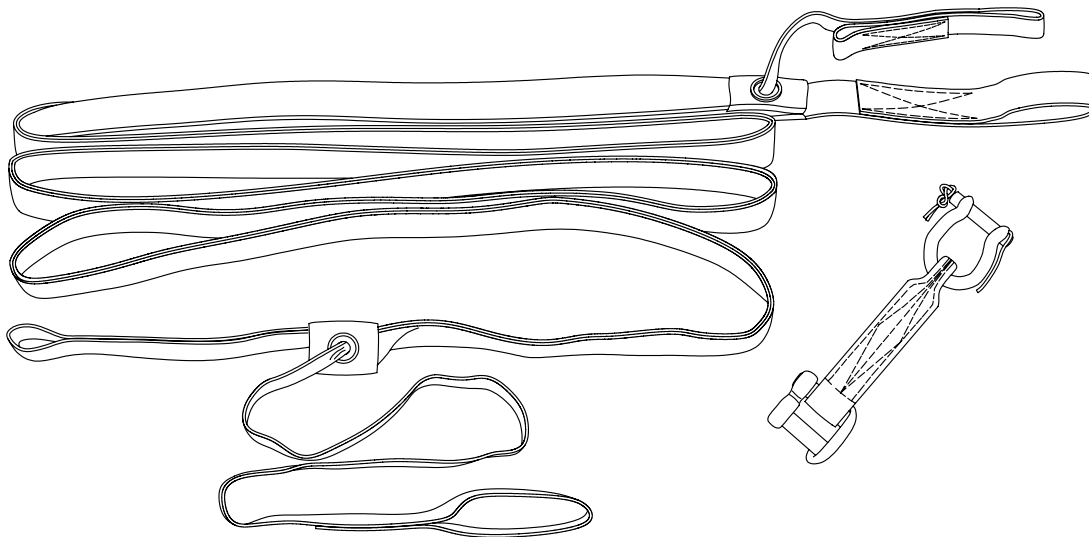




Table 1. Preventive Maintenance Checks and Services – continued

ITEM NO.	INTERVAL			ITEM TO BE CHECKED OR SERVICED	EQUIPMENT NOT READY/ AVAILABLE IF:
	B	D	A		
34	•			<p><b>Extraction Parachute Jettison System.</b> Check that all cables are securely connected.</p> <p>Blue LEDs on control box and blue LED on each Y-connector must light to indicate complete circuit.</p> <p>Blue LED lamp(s) must light to indicate the number of loads connected to the system.</p> <p>Check EPJD for squib-fired condition.</p> <p>Check that safety cap is installed on squib cable and squib cable is installed on squib. Refer to WP 0043 00.</p>	<p>Loose or damaged Connector.</p> <p>Circuit can not be completed</p> <p>Any load is not connected to the system properly</p> <p>Squib is fired.</p> <p>Safety cap and squib cable not installed on squib.</p>

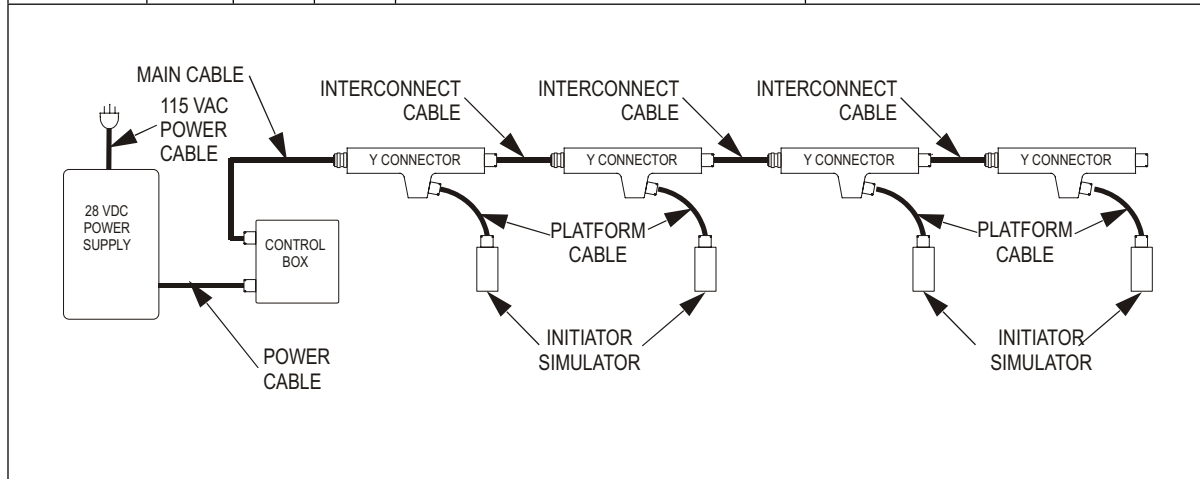


Table 1. Preventive Maintenance Checks and Services – continued

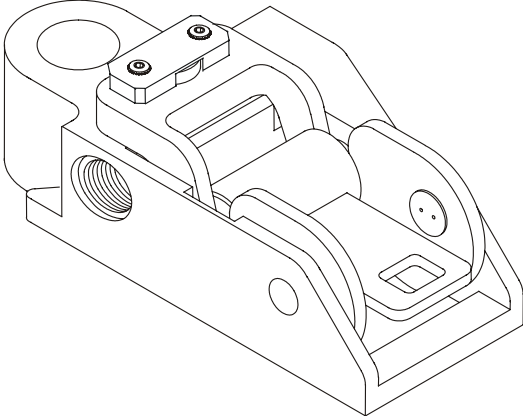
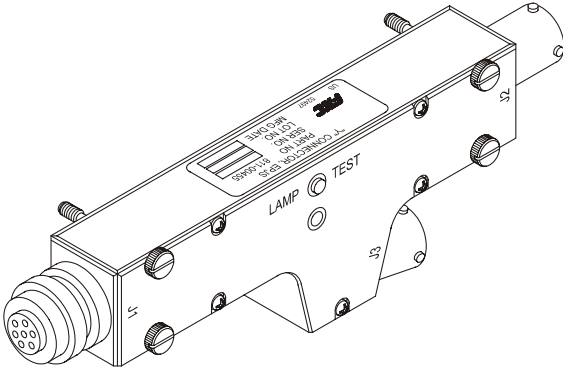
ITEM NO.	B – Before			D – During	A – After
	INTERVAL			ITEM TO BE CHECKED OR SERVICED	EQUIPMENT NOT READY/ AVAILABLE IF:
	B	D	A		
35	•			<b>Extraction Parachute Jettison System Device.</b> Check device for presence of foreign matter. Ensure that all parts are present and securely fastened together. Refer to WP 0044 00.	Device is not complete or has foreign matter present.
					
36	•			<b>Y-Connector.</b> Check Y-connector for secure attachment. Ensure LED illuminates when lamp test is depressed. Refer to WP 0045 00.	Y-connector has been forced off mounting area. LED does not illuminate when Lamp Test is depressed.
					

Table 1. Preventive Maintenance Checks and Services – continued

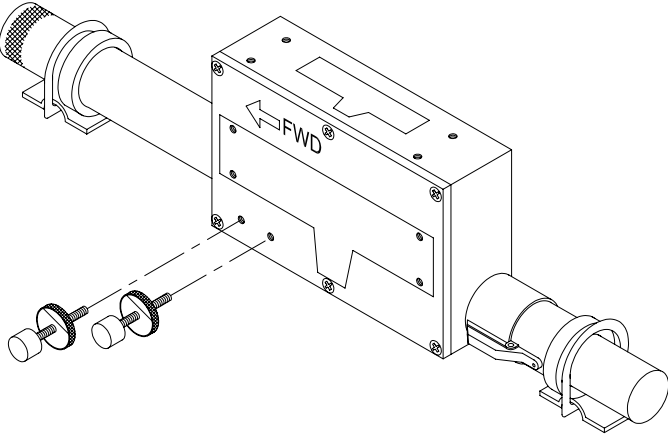
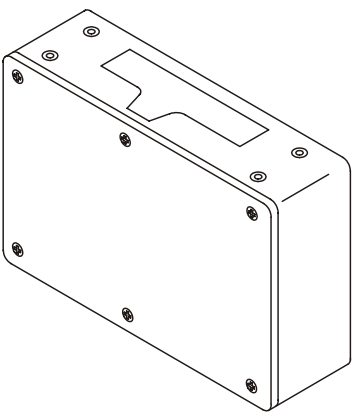
ITEM NO.	B – Before			D – During	A – After
	INTERVAL			ITEM TO BE CHECKED OR SERVICED	EQUIPMENT NOT READY/ AVAILABLE IF:
	B	D	A		
37	•			<b>Y-Connector Mounting Box (C-130, C-141, C-17).</b> Check for missing components, proper operation of extendable arms, ability to mount Y-connector to both positions, and damage. Refer to WP 0046 00.	Mounting box cannot secure Y-connector.
					
38	•			<b>Y-Connector Mounting Box (C-5).</b> Check for missing components, ability to mount Y-connector, and damage. Refer to WP 0046 00.	Mounting box cannot secure Y-connector.
					

Table 1. Preventive Maintenance Checks and Services – continued

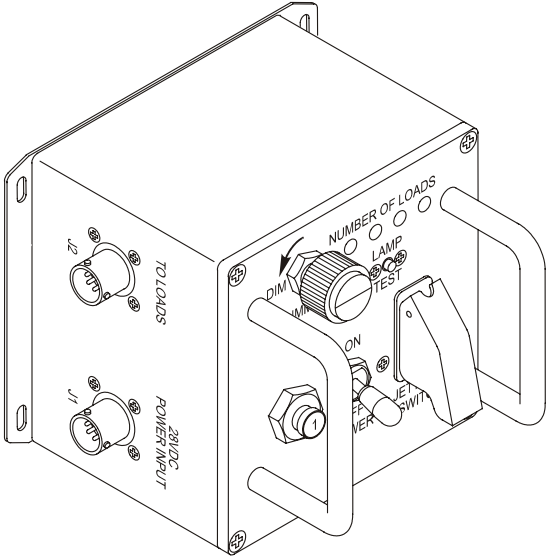
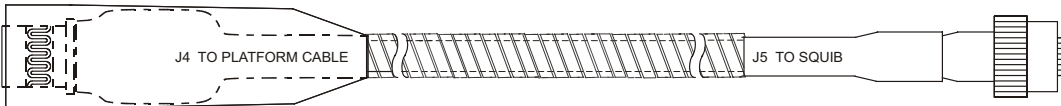
ITEM NO.	INTERVAL			ITEM TO BE CHECKED OR SERVICED	EQUIPMENT NOT READY/ AVAILABLE IF:
	B	D	A		
39	•			<b>Control Box.</b> Check for missing components and damage affecting functionality. Refer to WP 0047 00.	Box is not complete or obvious damage is found affecting functionality.
 <p>The diagram shows a rectangular control box with a handle on the right side. On the front panel, there are several controls: a 'DIMMER' knob, a 'NUMBER OF LOADS' selector with three positions, a 'LAMP TEST' button, and a 'JET SWITCH' with 'ON' and 'OFF' positions. On the left side, there are two circular ports labeled 'J2' and 'J1'. The 'J2' port is labeled 'TO LOADS' and the 'J1' port is labeled '28VDC POWER INPUT'.</p>					
40	•			<b>Squib Cable.</b> Check flexible cable wrap for excessive abrasions, cuts, wear, and deformation. Refer to WP 0044 00.	Cable covering is damaged and not protecting squib cable.
 <p>The diagram shows a long, thin cable with a textured outer sheath. At the left end, there is a connector labeled 'J4 TO PLATFORM CABLE'. At the right end, there is a connector labeled 'J5 TO SQUIB'.</p>					

Table 1. Preventive Maintenance Checks and Services – continued

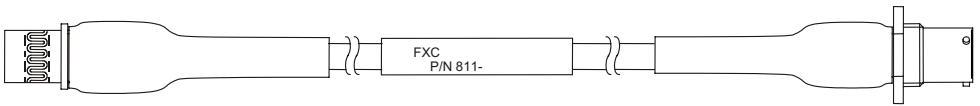
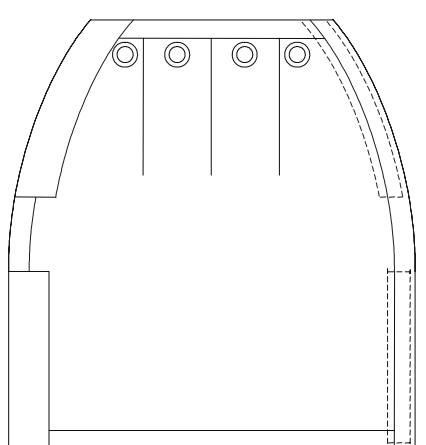
ITEM NO.	B – Before			D – During	A – After
	INTERVAL			ITEM TO BE CHECKED OR SERVICED	EQUIPMENT NOT READY/ AVAILABLE IF:
	B	D	A		
41	•			<p><b>Extraction Parachute Jettison System, Cables.</b> Check cables for cuts, nicks, or dry rot. Check for broken cable covering. Check for cracked plug or damaged connectors. Make sure connector pins are straight and aligned with mating receptacle. Refer to WPs 0048 00 – 0051 00, 0055 00, and 0056 00.</p>	Cable is damaged.
					
42	•			<p><b>Protective Cover.</b> Check for rips, tears, holes, loose or damaged fastener tape, and damaged or missing grommets. Refer to WP 0052 00.</p>	Cover has rips, tears, holes, loose or damaged fastener tape, or damaged or missing grommets.
					

Table 1. Preventive Maintenance Checks and Services – continued

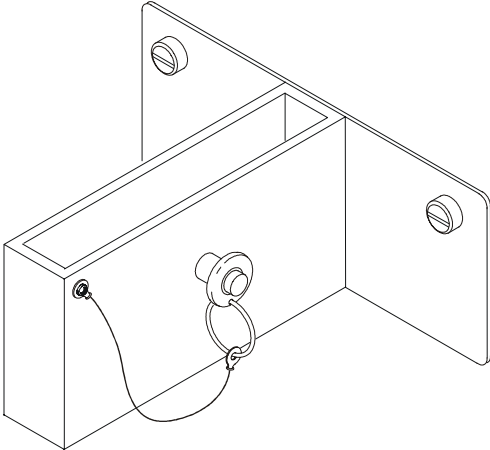
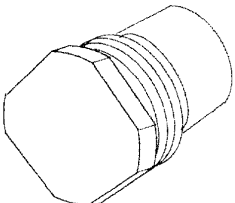
ITEM NO.	INTERVAL			ITEM TO BE CHECKED OR SERVICED	EQUIPMENT NOT READY/ AVAILABLE IF:
	B	D	A		
43	•			<b>Y-Connector Mounting Box Tie-down Bracket (C-5).</b> Check tie-down bracket for missing components, ability to mount Y-connector mounting box, and damage. Refer to WP 0054 00.	Tie-down bracket cannot secure Y-connector mounting box.
					
44	•			<b>Safety Cap.</b> Check that safety cap is installed on squib cable and for damage. Refer to WP 0057 00.	Safety cap is missing or damaged.
					

Table 1. Preventive Maintenance Checks and Services – continued

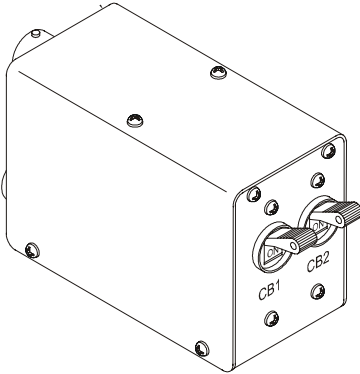
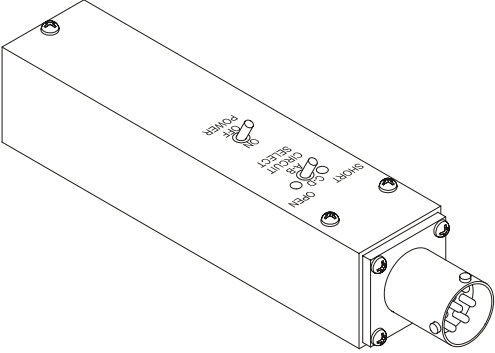
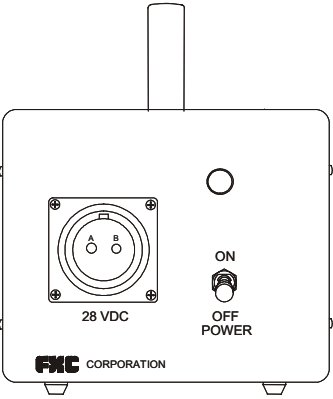
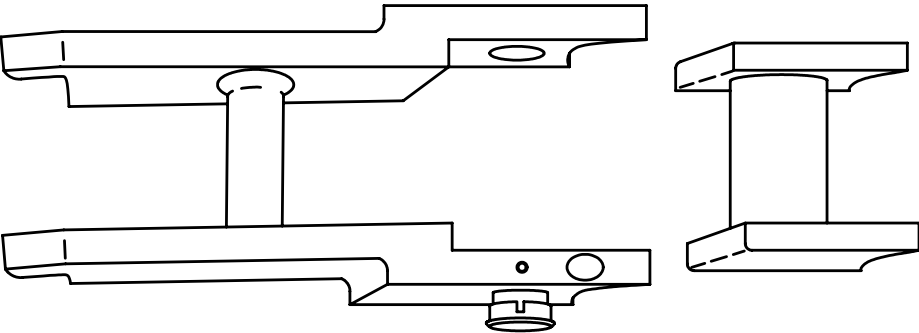
ITEM NO.	INTERVAL			ITEM TO BE CHECKED OR SERVICED	EQUIPMENT NOT READY/AVAILABLE IF:
	B	D	A		
45	•			<b>Initiator Simulator.</b> Check for missing components and damage affecting functionality. Refer to WP 0058 00.	Initiator simulator is no complete or obvious damage is found affecting functionality.
					
46	•			<b>Squib Tester.</b> Check for missing components and damage affecting functionality. Batteries are serviceable and LEDs illuminate. Refer to WP 0059 00.	Squib tester is not complete or obvious damage is found affecting functionality. Batteries are dead, or LEDs do no illuminate.
					

Table 1. Preventive Maintenance Checks and Services – continued

ITEM NO.	B – Before			D – During	A – After
	INTERVAL			ITEM TO BE CHECKED OR SERVICED	EQUIPMENT NOT READY/AVAILABLE IF:
B	D	A			
47	•			<b>28 VDC Power Supply.</b> Check for missing components and damage affecting functionality. Refer to WP 0060 00.	28 VDC power supply is not complete or obvious damage is found affecting functionality.
					
48	•			<b>Link, Parachute Connector.</b> Inspect link for rough areas, bends or cracks.	<b>Link, Parachute Connector</b> has rough areas, bends, or cracks. Detent spring does not operate freely.
					
<p><b>END OF TABLE</b></p>					

END OF WORK PACKAGE



**ANCILLARY EQUIPMENT FOR LOW VELOCITY AIR DROP SYSTEMS (LVADS)  
PREVENTIVE MAINTENANCE CHECKS AND SERVICES (PMCS)  
AFTER PROCEDURES**

**NOTE**

All PMCS inspections will be a Technical/Rigger Inspection.

**Table 2. Preventive Maintenance Checks and Services**

ITEM NO.	INTERVAL			ITEM TO BE CHECKED OR SERVICED	EQUIPMENT NOT READY/ AVAILABLE IF:
	B	D	A		
1			•	<b>Multi-Loop Line.</b> Inspect multi-loop link for loose or broken stitching, cuts, worn or frayed webbing and presence of foreign matter.	Multi-loop line has loose or broken stitching, cuts, worn or frayed webbing, or foreign matter present.

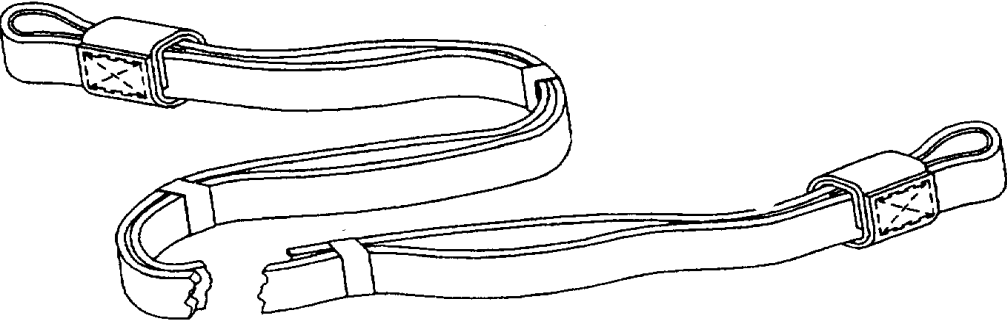


Table 2. Preventive Maintenance Checks and Services - continued

B – Before

D – During

A – After

ITEM NO.	INTERVAL			ITEM TO BE CHECKED OR SERVICED	EQUIPMENT NOT READY/ AVAILABLE IF:
	B	D	A		
2			<ul style="list-style-type: none"> <li>•</li> </ul>	<b>Extraction Force Transfer Coupling.</b> Inspect extraction force transfer coupling for presence of foreign matter. Ensure that all parts are present and securely fastened together.	Extraction force transfer coupling is not complete or has foreign matter present.

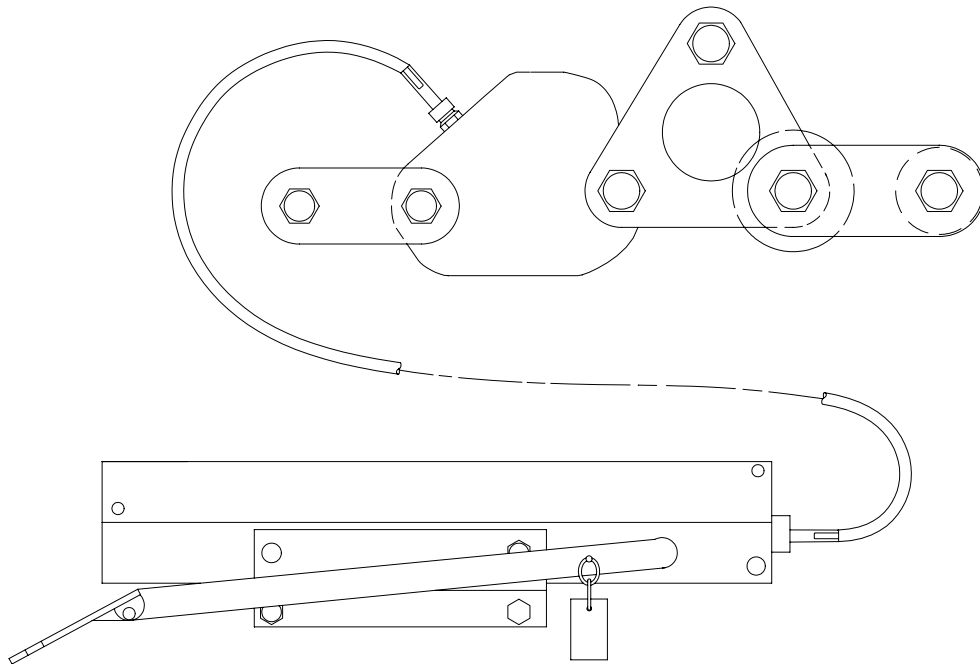
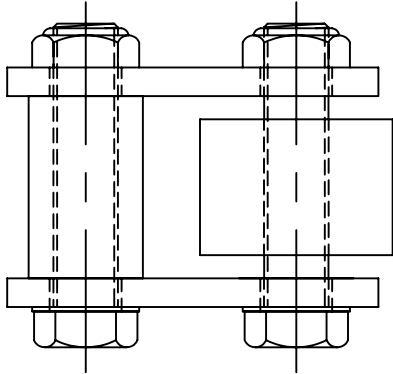
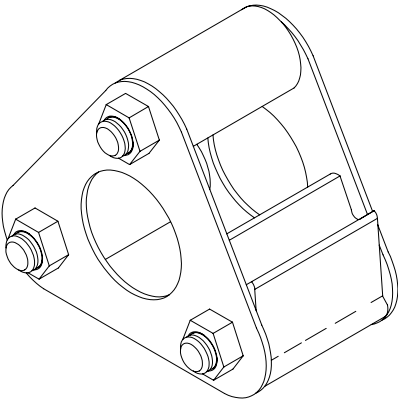


Table 2. Preventive Maintenance Checks and Services - continued

ITEM NO.	INTERVAL			ITEM TO BE CHECKED OR SERVICED	EQUIPMENT NOT READY/ AVAILABLE IF:
	B	D	A		
3			<ul style="list-style-type: none"> <li> <b>EFTC Link Adapter Assembly.</b> Inspect link assembly adapter for rough areas, bends, or cracks. Ensure that threads are not stripped or damaged.                 </li> </ul>	Link assembly adapter has rough areas, bends, or cracks. Threads are stripped.	
					
4			<ul style="list-style-type: none"> <li> <b>EFTC 3-Point Link Adapter Assembly.</b> Inspect link assembly, coupling for rough areas, bends, or cracks. Ensure that threads are not stripped or damaged.                 </li> </ul>	Link assembly, coupling has rough areas, bends, or cracks. Threads are stripped.	
					

**Table 2. Preventive Maintenance Checks and Services - continued**

**B – Before**

**D – During**

**A – After**

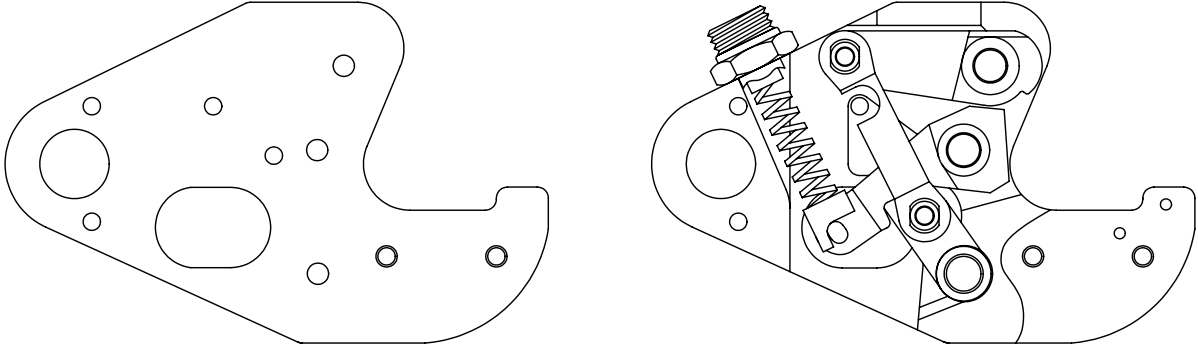
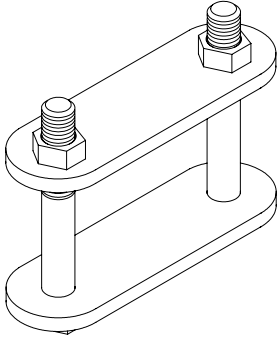
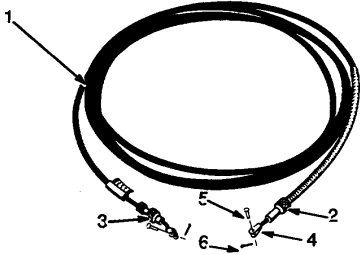
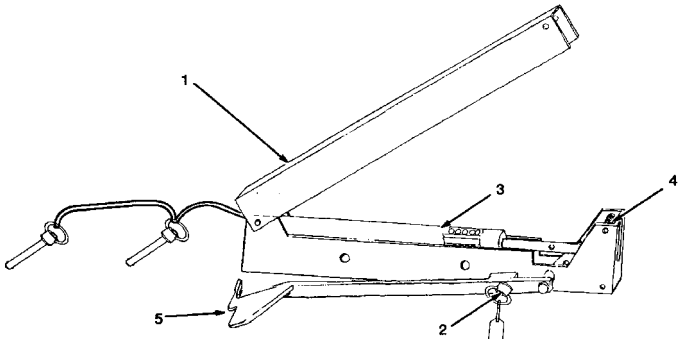
ITEM NO.	INTERVAL			ITEM TO BE CHECKED OR SERVICED	EQUIPMENT NOT READY/ AVAILABLE IF:
	B	D	A		
5			•	<b>EFTC Latch Assembly.</b> Inspect latch assembly coupling for rough areas, bends, cracks, or foreign material. Check that the retainer hook releases when the latch assembly adapter is activated.	Latch assembly coupling has rough areas, bends, or cracks, or foreign material is present. Retainer hook does not release when the latch assembly adapter is activated.
					
6			•	<b>Latch Connector Assembly.</b> Inspect for rough areas, bends or cracks. Ensure the threads are not stripped or damaged.	Assembly has rough areas, bends or cracks. Threads are stripped.
					

Table 2. Preventive Maintenance Checks and Services - continued

ITEM NO.	B – Before			D – During	A – After
	INTERVAL			ITEM TO BE CHECKED OR SERVICED	EQUIPMENT NOT READY/ AVAILABLE IF:
	B	D	A		
7			<ul style="list-style-type: none"> <li> <b>EFTC Cable Assembly.</b> Inspect cable for bends or kinks. Check that cable moves freely within its cover. Ensure that cable's cover is not broken, that the terminals operate properly, and that the threads are not stripped or damaged. Ensure the adjusting collar set screws are tight. Inspect yokes for rough areas, bends, or cracks. Ensure that shank pins and cotter pins are present.                 </li> </ul>	<p>Cable has bends or kinks. Cable does not move freely within its cover. Cable's cover is broken or damaged. Terminals do not operate properly or threads are stripped or damaged. Adjusting collar set screws are loose. Yokes have rough areas, bends, or cracks. Shank pins or cotter pins are missing.</p>	
					
8			<ul style="list-style-type: none"> <li> <b>EFTC Actuator Assembly.</b> Check assembly operation. Inspect for excessive wear, bends, breaks, or weld separation. Ensure that threads are not stripped or damaged. Check that safety pin and cam arm spring are present. Ensure that actuator arm is not bent, the axle nut is not loose, and there is not excessive play between arm and axle.                 </li> </ul>	<p>Assembly is inoperable or has excessive wear, bends, breaks, or weld separation. Threads are stripped or damaged. Safety pin or cam arm spring is missing. Actuator arm is bent, the axle nut is loose, or there is excessive play between arm and axle.</p>	
					

**Table 2. Preventive Maintenance Checks and Services - continued**

**B – Before**

**D – During**

**A – After**

ITEM NO.	INTERVAL			ITEM TO BE CHECKED OR SERVICED	EQUIPMENT NOT READY/ AVAILABLE IF:
	B	D	A		
9			<ul style="list-style-type: none"> <li> <b>M-1 Cargo Parachute Release.</b>                      Check release operation. Ensure that, when using a 15-second timer, it activates within 12 and 16-seconds. Check for excessive wear or foreign material.                 </li> </ul>	Release does not operate properly. Timer is not accurate. Release is worn or has foreign material present.	

**NOTE**

The original Face Plate Bolts, NSN 5306-00-207-8362/Part Number AN6-25A has been temporarily replaced by NSN 5306-00-638-5821/Part Number AN6H-25A (H denotes a hole drilled in the bolt head). Either bolt is acceptable until the original bolt is brought back into the inventory.

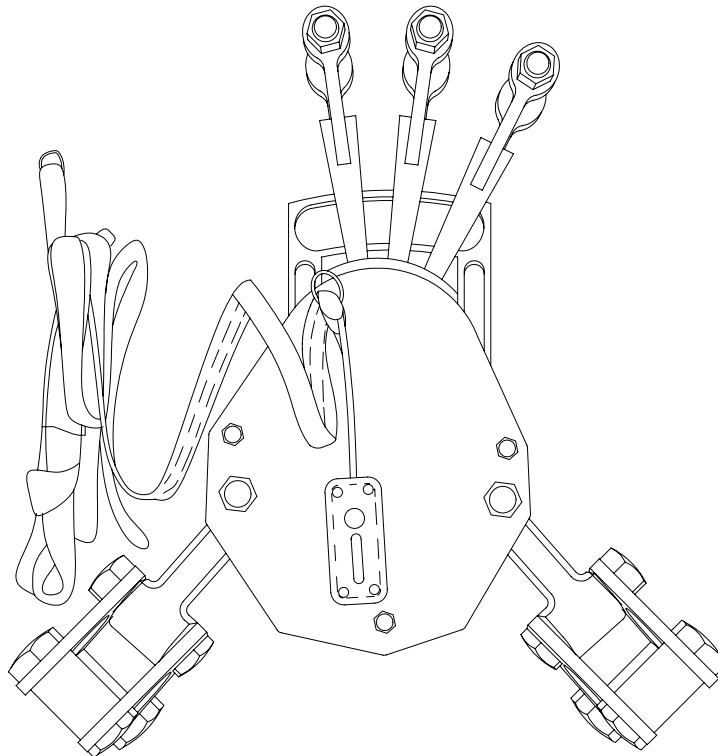


Table 2. Preventive Maintenance Checks and Services – continued

B – Before

D – During

A – After

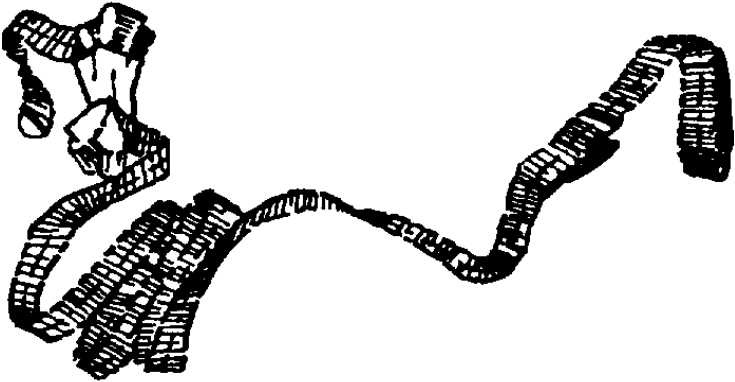
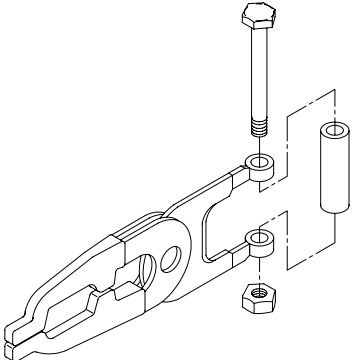
ITEM NO.	INTERVAL			ITEM TO BE CHECKED OR SERVICED	EQUIPMENT NOT READY/ AVAILABLE IF:
	B	D	A		
10			<ul style="list-style-type: none"> <li> <b>Lanyard Arming Wire.</b>                      Inspect lanyard for loose or broken stitching, cuts, worn, or frayed webbing, and presence of foreign matter.                 </li> </ul>	Lanyard has loose or broken stitching, cuts, or worn or frayed webbing, or foreign material is present.	
					
11			<ul style="list-style-type: none"> <li> <b>Parachute Connector.</b>                      Inspect connector for bends, cracks, burrs, and rough areas. Check if threads are stripped or cracked. Check if arms engage into the retainer clamp.                 </li> </ul>	Connector has bends, burrs, or rough areas. Threads are stripped or cracked. Arms do not engage into the retaining clamp.	
					

Table 2. Preventive Maintenance Checks and Services – continued

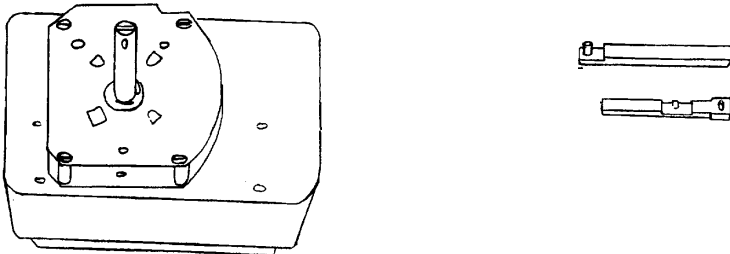
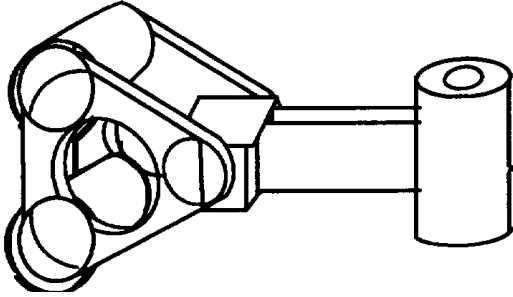
ITEM NO.	B – Before			D – During	A – After
	INTERVAL			ITEM TO BE CHECKED OR SERVICED	EQUIPMENT NOT READY/ AVAILABLE IF:
	B	D	A		
12			<ul style="list-style-type: none"> <li> <b>Timer Delay Assembly.</b>                      Inspect timer assembly for bends, cracks, burrs, rough areas, and foreign material. Check if timer activates at the appropriate time and if stem rotates freely in mounting block. Ensure that keys retract at the end of timing sequence.                 </li> </ul>	Timer assembly has bends, cracks, burrs, or rough areas or foreign material is present. Timer does not activate at the appropriate time or stem does not rotate freely in mounting block. Keys do not retract at the end of time sequence.	
					
13			<ul style="list-style-type: none"> <li> <b>Lower Link Suspension.</b>                      Inspect link for bends, breaks, cracks, burrs, and rough areas. Check for stripped or damaged threads.                 </li> </ul>	Link has bends, breaks, cracks. Surfaces have burrs or rough areas. Threads are stripped or damaged.	
					



Table 2. Preventive Maintenance Checks and Services – continued

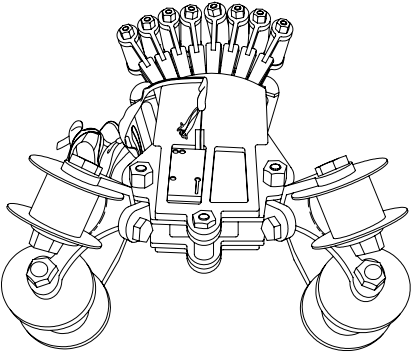
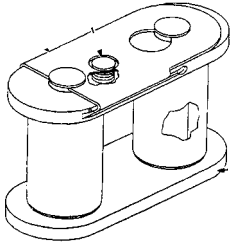
ITEM NO.	B – Before			D – During	A – After
	INTERVAL			ITEM TO BE CHECKED OR SERVICED	EQUIPMENT NOT READY/ AVAILABLE IF:
	B	D	A		
14			<ul style="list-style-type: none"> <li> <b>M-2 Cargo Parachute Release (42,000-lbs).</b> Check release operation. Ensure that, when using a 15-second timer, it activates within 12 and 16-seconds. Check for excessive wear or foreign material. Check lanyard for frayed material, cuts, and loose or broken stitching.                 </li> </ul>	Release does not operate properly. Timer is not accurate. Release is worn or has foreign material present.	
					
15			<ul style="list-style-type: none"> <li> <b>Type IV Single Suspension Link Assembly.</b> Inspect link for bends, breaks, cracks, burrs, or rough areas. Ensure proper operation of button and lock.                 </li> </ul>	Link has bends, breaks, cracks. Surfaces have burrs or rough areas. Button or lock does not function properly.	
<p><b>NOTE</b> No longer authorized for LVAD after 31 December 2003.</p> 					

Table 2. Preventive Maintenance Checks and Services – continued

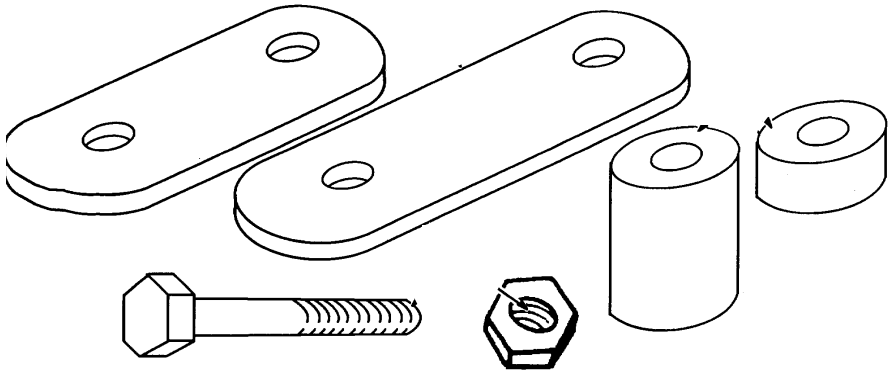
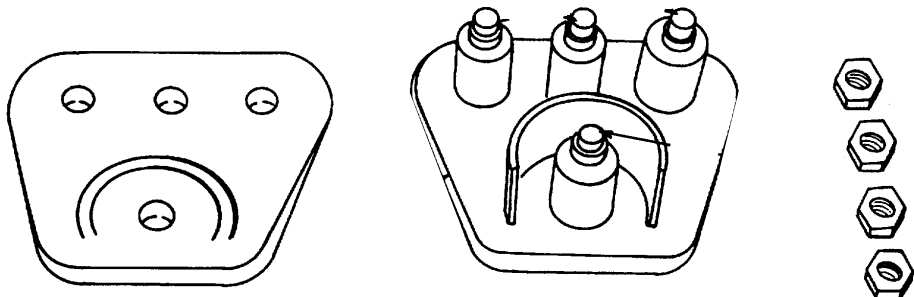
ITEM NO.	B – Before			D – During	A – After
	INTERVAL			ITEM TO BE CHECKED OR SERVICED	EQUIPMENT NOT READY/ AVAILABLE IF:
	B	D	A		
16			•	<b>Heavy-Duty Link Assembly.</b> Inspect plates and spacers for rough areas, bends, breaks, or cracks. Ensure that threads are not stripped or damaged.	Plate or spacer has rough areas, bends, breaks, or cracks. Threads are damaged or stripped.
					
17			•	<b>4-Point Link.</b> Inspect four-point link for rough areas, bends, breaks, and cracks. Ensure fastener threads are not stripped or damaged.	Link has rough areas, bends, breaks, and cracks. Fasteners have stripped or damaged threads.
					

Table 2. Preventive Maintenance Checks and Services – continued

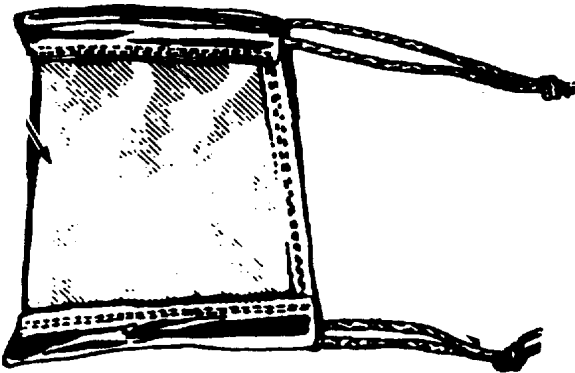
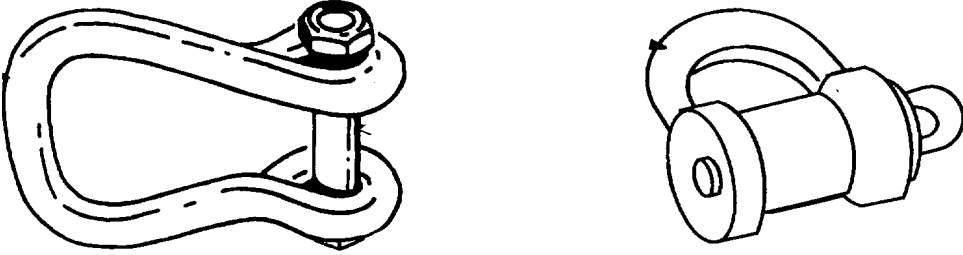
ITEM NO.	B – Before			D – During	A – After
	INTERVAL			ITEM TO BE CHECKED OR SERVICED	EQUIPMENT NOT READY/ AVAILABLE IF:
	B	D	A		
18			<ul style="list-style-type: none"> <li><b>Type IV Cover Link.</b> Inspect cover for loose or broken stitches, tears, damaged cord, or foreign material.</li> </ul>	Cover has loose or broken stitches, tears, damaged cord, or foreign matter present.	
<p><b>NOTE</b> No longer authorized for LVAD after 31 December 2003.</p> 					
19			<ul style="list-style-type: none"> <li><b>Aerial Delivery Clevis.</b> Inspect clevis for rough areas, bends, breaks, and cracks. Ensure fastener threads are not stripped or damaged.</li> </ul>	Clevis has rough areas, bends, breaks, and cracks. Fasteners have stripped or damaged threads.	
					

Table 2. Preventive Maintenance Checks and Services – continued

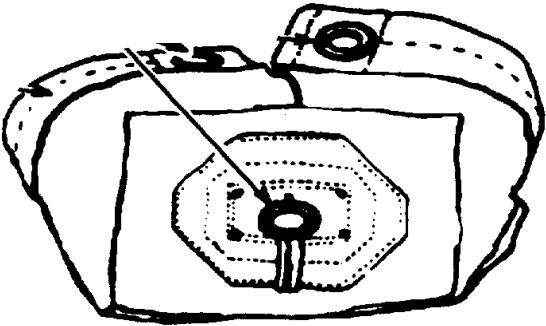
ITEM NO.	B – Before			D – During	A – After
	INTERVAL			ITEM TO BE CHECKED OR SERVICED	EQUIPMENT NOT READY/ AVAILABLE IF:
	B	D	A		
20			<ul style="list-style-type: none"> <li> <b>Clevis Cover.</b> Inspect cover for loose or broken stitches, tears, broken grommets, or foreign material.                     </li> </ul>	Cover has loose or broken stitches, tears, grommets are broken, or foreign material is present.	
21			<ul style="list-style-type: none"> <li> <b>Single Knife Parachute Release Strap.</b> Inspect strap for loose or broken stitching, cuts, worn and frayed webbing, or presence of foreign material. Check knife and fastener for rough areas, bends, breaks, and cracks. Check knife-edge for sharpness. Ensure that ferrule operates properly.                     </li> </ul>	Strap has loose or broken stitching, cuts, worn or frayed webbing, or foreign material is present. Knife or fastener has rough areas, bends, breaks, or cracks. Knife-edge is dull. Ferrule does not cover the safety aperture when unscrewed to the full open position.	

Table 2. Preventive Maintenance Checks and Services – continued

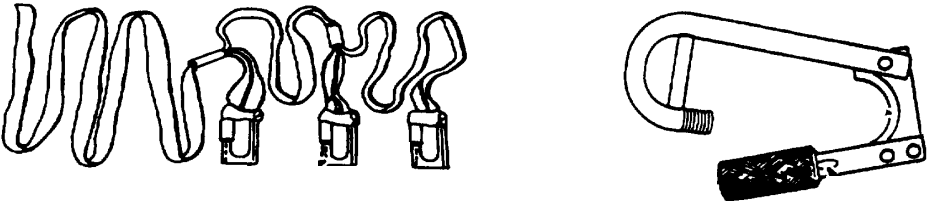
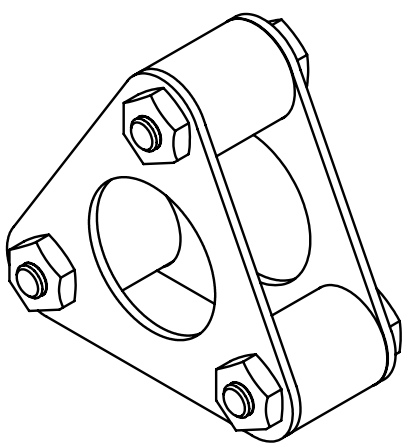
ITEM NO.	B – Before			D – During	A – After
	INTERVAL			ITEM TO BE CHECKED OR SERVICED	EQUIPMENT NOT READY/ AVAILABLE IF:
	B	D	A		
22			<ul style="list-style-type: none"> <li> <b>Multi-Knife Parachute Release Strap.</b> Inspect strap for loose or broken stitching, cuts, worn and frayed webbing, or presence of foreign material. Check knives for rough areas, bends, breaks, and cracks and knife-edges for sharpness. Ensure that ferrules operate properly.                 </li> </ul>		Strap has loose or broken stitching, cuts, worn or frayed webbing, or foreign material is present. A knife has rough areas, bends, breaks, or cracks or its edge is dull. A ferrule does not cover the safety aperture when unscrewed to the full open position.
					
24			<ul style="list-style-type: none"> <li> <b>3-Point Coupling Link Assembly.</b> Inspect three-point link for rough areas, bends, breaks, and cracks. Ensure fastener threads are not stripped or damaged.                 </li> </ul>		Link has rough areas, bends, breaks, and cracks. Fasteners have stripped or damaged threads.
					

Table 2. Preventive Maintenance Checks and Services – continued

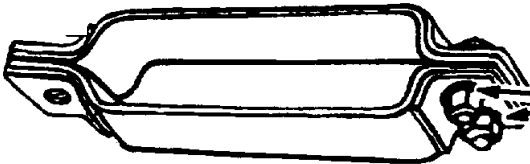
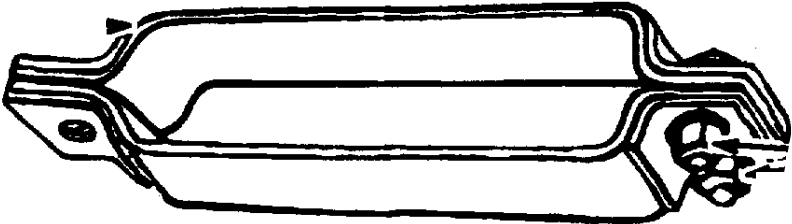
ITEM NO.	B – Before			D – During	A – After
	INTERVAL			ITEM TO BE CHECKED OR SERVICED	EQUIPMENT NOT READY/ AVAILABLE IF:
	B	D	A		
24			<ul style="list-style-type: none"> <li> <b>M-35 Suspension Bracket.</b>                      Inspect bracket for rough areas, bends, breaks, and cracks. Ensure fastener threads are not stripped or damaged.                 </li> </ul>	Bracket as rough areas, bends, breaks, and cracks. Fasteners have stripped or damaged threads.	
					
25			<ul style="list-style-type: none"> <li> <b>M-59 Suspension Bracket.</b>                      Inspect bracket for rough areas, bends, breaks, and cracks. Ensure fastener threads are not stripped or damaged.                 </li> </ul>	Bracket has rough areas, bends, breaks, and cracks. Fasteners have stripped or damaged threads.	
					

Table 2. Preventive Maintenance Checks and Services – continued

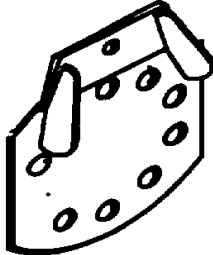
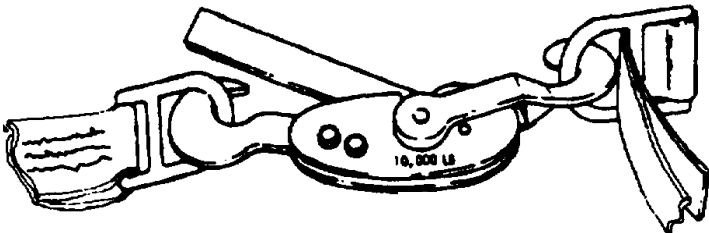
ITEM NO.	B – Before			D – During	A – After
	INTERVAL			ITEM TO BE CHECKED OR SERVICED	EQUIPMENT NOT READY/ AVAILABLE IF:
	B	D	A		
26			•	<b>Suspension Plate.</b> Inspect plate for rough areas, bends, breaks, and cracks.	Plate has rough areas, bends, breaks, and cracks.
					
27			•	<b>10K Cargo Tie-down.</b> Inspect tie-down for loose or broken stitching, frayed webbing, foreign material, or a defective binder.	Tie-down has loose or broken stitching or frayed webbing, foreign material is present, or the binder is defective.
					

Table 2. Preventive Maintenance Checks and Services – continued

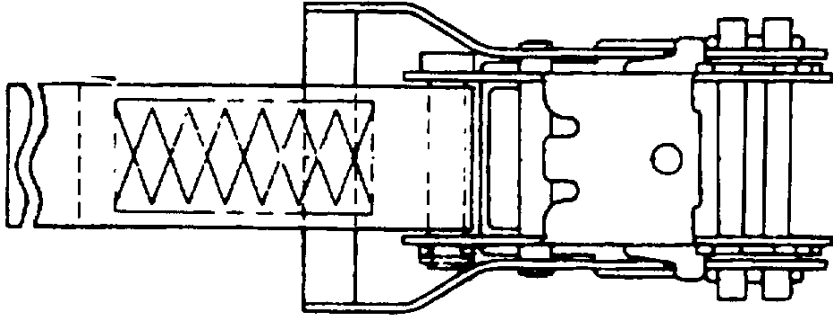
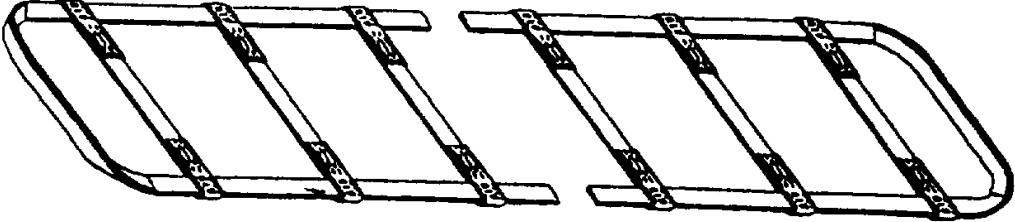
ITEM NO.	B – Before			D – During	A – After
	INTERVAL			ITEM TO BE CHECKED OR SERVICED	EQUIPMENT NOT READY/ AVAILABLE IF:
	B	D	A		
28			<ul style="list-style-type: none"> <li> <b>Quick Release Cargo Tie-down.</b> Inspect tie-down for loose or broken stitching, frayed webbing, foreign material, or a defective quick-release lever                     </li> </ul>	<p>Tie-down has loose or broken stitching or frayed webbing, foreign material is present, or the quick-release lever is defective.</p>	
					
29			<ul style="list-style-type: none"> <li> <b>Type IV Drive-Off Aid.</b> Inspect drive-off aid for loose or broken stitching, frayed webbing, or foreign material.                     </li> </ul>	<p>Drive-off aid has loose or broken stitching or frayed webbing. Foreign material is present.</p>	
					



Table 2. Preventive Maintenance Checks and Services – continued

B – Before

D – During

A – After

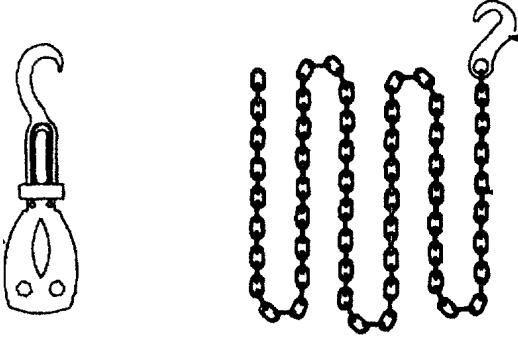
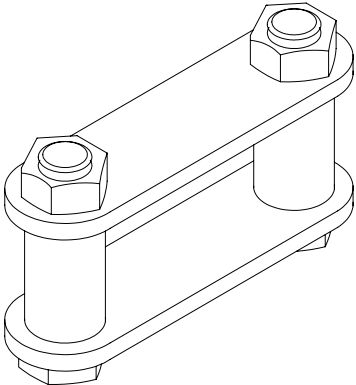
ITEM NO.	INTERVAL			ITEM TO BE CHECKED OR SERVICED	EQUIPMENT NOT READY/ AVAILABLE IF:
	B	D	A		
30			<ul style="list-style-type: none"> <li> <b>Aircraft Cargo Tie-down.</b> Inspect tie-down chain for rough areas, bends, breaks, cracks, rust, or foreign material. Ensure turnbuckle threads are not stripped or damaged.                 </li> </ul>	Tie-down chain has rough areas, bends, breaks, or cracks. Rust, or foreign material is present. Turnbuckle threads are stripped or damaged.	
					
31			<ul style="list-style-type: none"> <li> <b>3 3/4-Inch, 2-Point Link.</b> Inspect two-point link for rough areas, bends, breaks, and cracks. Ensure fastener threads are not stripped or damaged.                 </li> </ul>	Link has rough areas, bends, breaks, and cracks. Fasteners have stripped or damaged threads.	
					

Table 2. Preventive Maintenance Checks and Services – continued

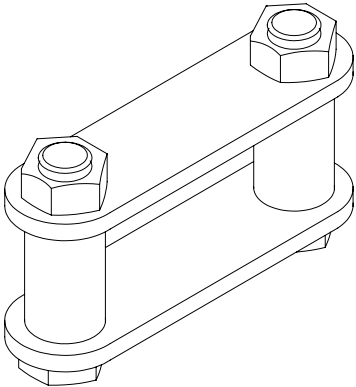
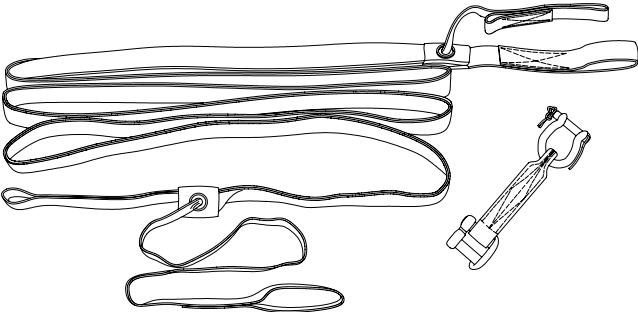
ITEM NO.	B – Before			D – During	A – After
	INTERVAL			ITEM TO BE CHECKED OR SERVICED	EQUIPMENT NOT READY/ AVAILABLE IF:
	B	D	A		
32			<ul style="list-style-type: none"> <li>•</li> </ul>	<p><b>5 ½-Inch, 2-Point Link.</b> Inspect two-point link for rough areas, bends, breaks, and cracks. Ensure fastener threads are not stripped or damaged.</p>	<p>Link has rough areas, bends, breaks, and cracks. Fasteners have stripped or damaged threads.</p>
					
33			<ul style="list-style-type: none"> <li>•</li> </ul>	<p><b>Release Away Static Line Assembly.</b> Check for loose or broken stitches. Inspect for frays, burns cuts or tears in webbing and sleeve. Check for loose or broken stitches, as well as missing or damaged hardware (grommets, 1-inch connector link). Ensure release line can move freely and there are no visible twists.</p>	<p>Static line has loose or broken stitching or frayed or cut webbing, damaged or missing hardware. Release does not move freely or is twisted.</p>
					

Table 2. Preventive Maintenance Checks and Services – continued

ITEM NO.	INTERVAL			ITEM TO BE CHECKED OR SERVICED	EQUIPMENT NOT READY/ AVAILABLE IF:
	B	D	A		
34			<ul style="list-style-type: none"> <li> <b>Extraction Parachute Jettison System.</b> Check all cables for damage.                       Check EPJD for squib-fired condition.                 </li> </ul>	Cable is damaged.  Squib is fired.	
35			<ul style="list-style-type: none"> <li> <b>Extraction Parachute Jettison System Device.</b> Check EPJD for presence of foreign matter. Ensure that all parts are present and securely fastened together.                 </li> </ul>	Device is not complete or has foreign matter present.	

Table 2. Preventive Maintenance Checks and Services – continued

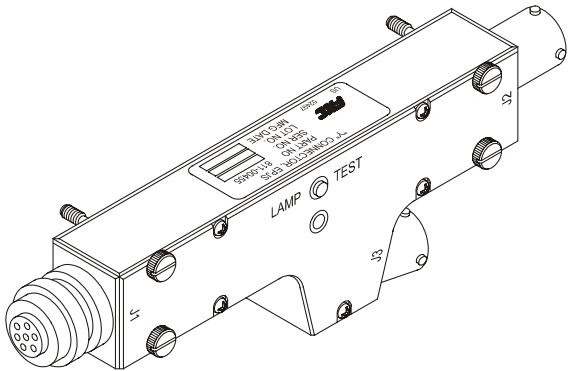
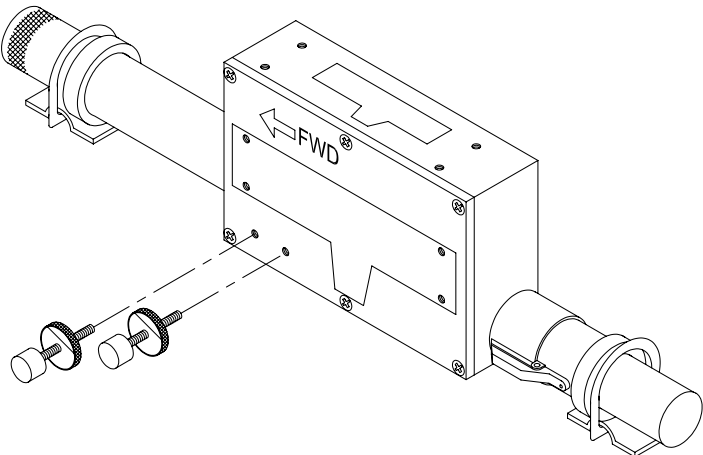
ITEM NO.	B – Before			D – During	A – After
	INTERVAL			ITEM TO BE CHECKED OR SERVICED	EQUIPMENT NOT READY/ AVAILABLE IF:
	B	D	A		
36			<ul style="list-style-type: none"> <li>•</li> </ul>	<p><b>Y-Connector.</b> Check Y-connector for secure attachment. Ensure LED illuminates when lamp test is depressed.</p>	<p>Y-connector has been forced off mounting area. LED does not illuminate when lamp test is depressed.</p>
					
37			<ul style="list-style-type: none"> <li>•</li> </ul>	<p><b>Y-Connector Mounting Box (C-130, C-141, C-17).</b> Check Y-connector mounting box for missing components, proper operation of extendable arms, ability to mount Y-connector to both positions, and damage.</p>	<p>Mounting box cannot secure Y-connector.</p>
					

Table 2. Preventive Maintenance Checks and Services – continued

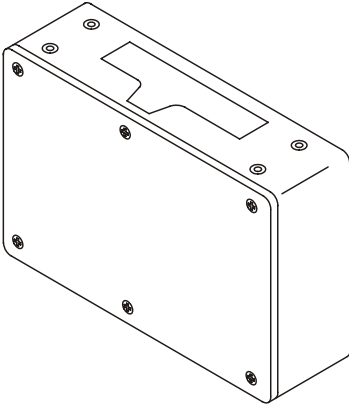
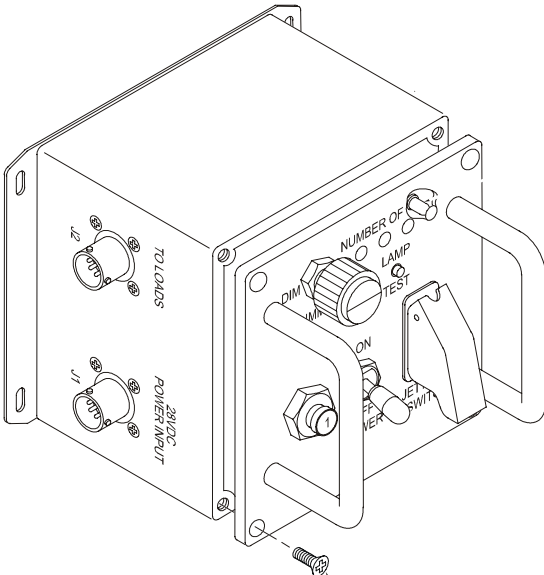
ITEM NO.	INTERVAL			ITEM TO BE CHECKED OR SERVICED	EQUIPMENT NOT READY/ AVAILABLE IF:
	B	D	A		
38			<ul style="list-style-type: none"> <li>• <b>Y-Connector Mounting Box (C-5).</b> Check Y-connector mounting box for missing components, ability to mount Y-connector, and damage.</li> </ul>	Mounting box cannot secure Y-connector or tie-down bracket.	
					
39			<ul style="list-style-type: none"> <li>• <b>Control Box.</b> Check for missing components and damage affecting serviceability.</li> </ul>	Box is not complete or obvious damage is found affecting functionality.	
					

Table 2. Preventive Maintenance Checks and Services – continued

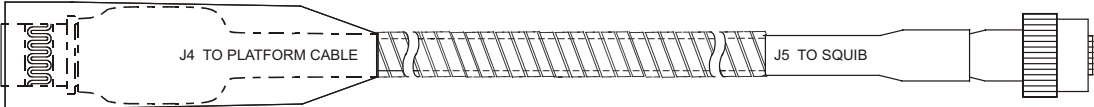
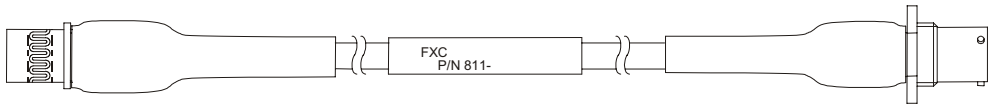
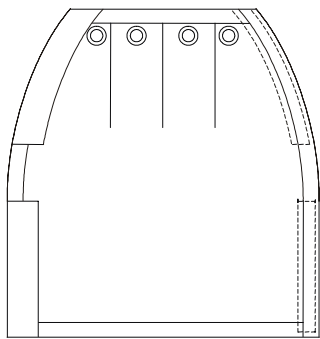
ITEM NO.	B – Before			D – During	A – After
	INTERVAL			ITEM TO BE CHECKED OR SERVICED	EQUIPMENT NOT READY/ AVAILABLE IF:
	B	D	A		
40			•	<b>Squib Cable.</b> Check flexible cable wrap for excessive abrasions, cuts, wear, and deformation.	Cable covering is damaged and not protecting squib cable.
					
41			•	<b>Extraction Parachute Jettison System Cables.</b> Check all cables for cuts, nicks, and dry rot. Check for broken cable covering. Check for cracked plug or connectors. Make sure connector pins are straight and aligned with mating receptacle.	Cable is damaged.
					
42			•	<b>Protective Cover.</b> Check cover for rips, tears, holes, loose or damaged fastener tape, and damaged or missing grommets.	Cover has rips, tears, holes, loose or damaged fastener tape, and damaged or missing grommets.
					

Table 2. Preventive Maintenance Checks and Services – continued

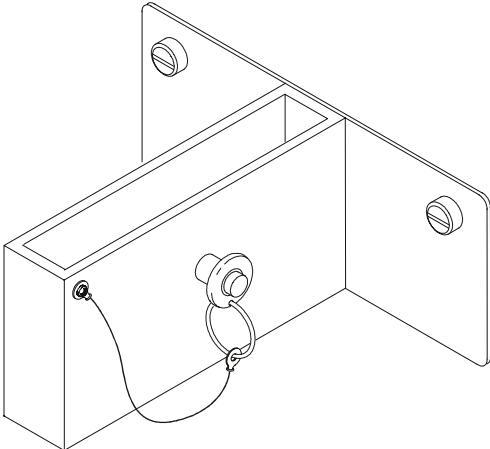
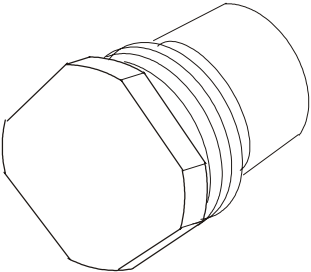
ITEM NO.	B – Before			D – During	A – After
	INTERVAL			ITEM TO BE CHECKED OR SERVICED	EQUIPMENT NOT READY/ AVAILABLE IF:
	B	D	A		
43			<ul style="list-style-type: none"> <li> <b>Y-Connector Mounting Box Tie-down Bracket (C-5).</b> Check tie-down bracket for missing components, ability to mount Y-connector mounting box, and damage.                     </li> </ul>	Tie-down bracket cannot secure Y-connector mounting box.	
					
44			<ul style="list-style-type: none"> <li> <b>Safety Cap.</b> Check that safety cap is installed on squib cable, and for damage.                     </li> </ul>	Safety cap is missing or damaged.	
					

Table 2. Preventive Maintenance Checks and Services – continued

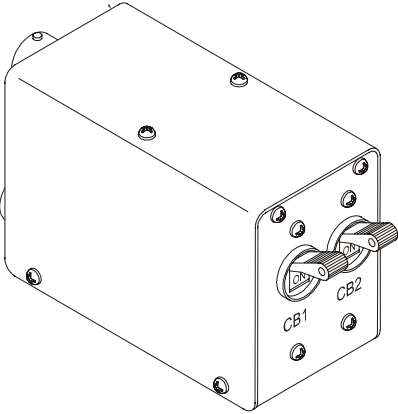
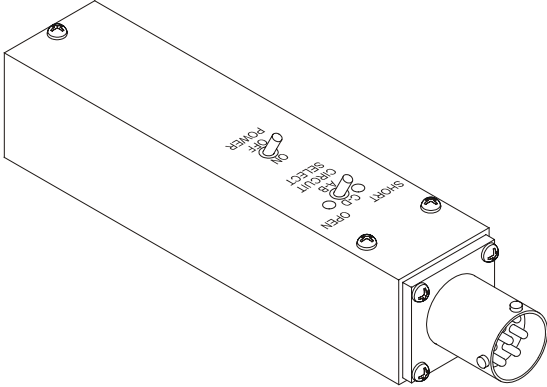
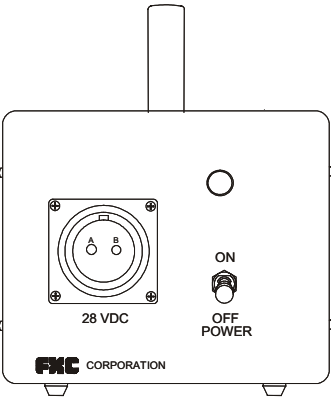
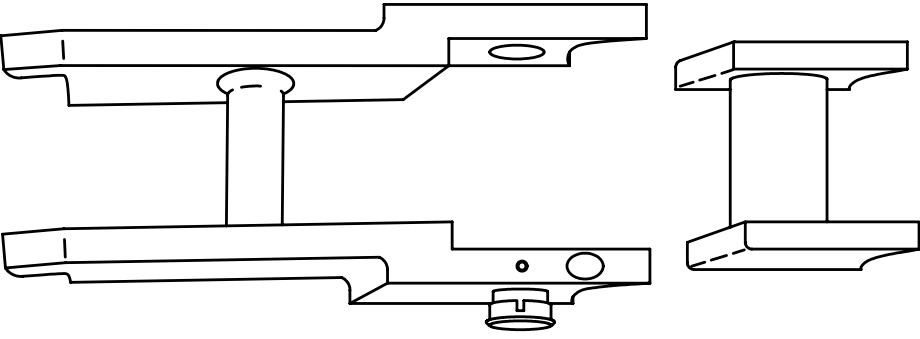
ITEM NO.	INTERVAL			ITEM TO BE CHECKED OR SERVICED	EQUIPMENT NO READY/AVAILABLE IF:
	B	D	A		
45			•	<b>Initiator Simulator.</b> Check for missing components and damage affecting functionality.	Initiator simulator is no complete or obvious damage is found affecting functionality.
					
46			•	<b>Squib Tester.</b> Check for missing components and damage affecting functionality. Batteries are serviceable and LEDs illuminate.	Squib tester is not complete or obvious damage is found affecting functionality. Batteries are dead, or LEDs do no illuminate.
					



Table 2. Preventive Maintenance Checks and Services – continued

ITEM NO.	INTERVAL			ITEM TO BE CHECKED OR SERVICED	EQUIPMENT NO READY/AVAILABLE IF:
	B	D	A		
47			•	<b>28 VDC Power Supply.</b> Check for missing components and damage affecting functionality.	28 VDC power supply is not complete or obvious damage is found affecting functionality.
					
48			•	<b>Link, Parachute Connector.</b> Inspect link for rough areas, bends or cracks.	Link, Parachute Connector has rough areas, bends, or cracks. Detent spring does not operate freely.
					
<p><b>END OF TABLE</b></p>					

**AFTER USE RECEIPT**

Used equipment will be processed as prescribed in this WP.

**LUBRICATION SERVICE INTERVALS**

The ancillary airdrop equipment does not require lubrication services.

**END OF WORK PACKAGE**

**CHAPTER 3**

**UNIT MAINTENANCE INSTRUCTIONS  
FOR  
ANCILLARY EQUIPMENT FOR  
LOW VELOCITY AIR DROP SYSTEMS (LVADS)**



---

**UNIT MAINTENANCE  
ANCILLARY EQUIPMENT FOR LOW VELOCITY AIR DROP SYSTEMS (LVADS)  
INSPECTION**

---

**THIS TASK COVERS:**

- Technical/Rigger-Type
  - Routine Inspection
  - In-Storage
  - Equipment Disposition
- 

**INITIAL SETUP:****Equipment Condition**

Laid out on packing table or other suitable surface.

**References**

DA PAM 738-751; TB 43-002-43;  
DA PAM 738-750; AR 750-1; WP 008 00;  
WP 0064 00

**Personnel Required**

Two, 92R (10) Parachute Rigger

---

**TECHNICAL/RIGGER INSPECTION**

Technical/rigger-type inspection is a complete and thorough inspection of an individual airdrop item, including associated parts and components. The following paragraphs outline criteria applicable to accomplishing a technical/rigger-type inspection. The inspection will be performed by a qualified parachute rigger in accordance with AR 750-32 (AF AFSCs 2T251/2A754/1A251 trained and certified by USAQMC&S Fabrication of Aerial Delivery Loads Course).

**Inspection Intervals**

1. Upon initial receipt of procured equipment to a using unit by a supply source.
2. Immediately before equipment is packed or rigged for use in airdrop operations.
3. Before and after repairs or modifications are made.
4. At any other time as deemed necessary by the airdrop equipment maintenance officer.

**Inspection Function Requirement.** Normally, a technical/rigger-type inspection will be performed at a packing, rigging, or repair activity. The inspection of initial receipt items will be performed as a separate function from packing or rigging operations.

When the inspection is conducted at a rigging activity, the item to be inspected will be placed in proper layout on a packing table or a suitable sized floor area. Should a defect or damage be discovered at any point during the inspection, the inspection will be terminated and the defective item will be processed and forwarded to a repair activity. The repair activity, in turn, will conduct a technical/rigger-type inspection that will be performed by only those parachute rigger personnel cited in AR 750-32.

Any defect discovered during a unit level repair activity that exceeds the capability of that activity will require the affected item to be evacuated to a direct support maintenance facility determination of economic repair and its application, if applicable.

---

**Technical/Rigger-Type Inspection Procedures**

1. Overall Inspection. An overall inspection will be made of airdrop equipment to check to following:
  - a. Log Record/Parachute Inspection Data Pocket and Form. As applicable, inspect the assembly log record/parachute inspection data pocket to ensure the Army Parachute Log Record (DA Form 3912) is enclosed and properly attached. Further, remove the log record from the item and evaluate the recorded items.
  - b. Assembly Completeness. Ensure that the applicable assembly is complete and no components or parts are missing.
  - c. Operational Adequacy. Check the item components and parts to ensure proper assembly that includes attachment and alignment, and that the assembled product functions in the prescribed manner. Further, ensure that no stitch formation or sewn seam has been omitted.
  - d. Markings and Paint. Inspect each assembly and related components for faded, illegible, obliterated, or missing informational data, identification numbers, and warning marks. Check for chipped, worn or peeled paint, if applicable.
  - e. Foreign Material and Stains. Inspect each assembly and related components for dirt or other foreign material. Also check for evidence of mildew, moisture, oil, grease, resin, or peeled paint, as applicable.
2. Detailed Inspection. In addition to the overall inspection performed in the OVERALL INSPECTION paragraph, above, a detailed inspection will be performed in the materials that constitute the assembly or component construction using the following criteria, as applicable:
  - a. Metal. Inspect for rust, corrosion, dents, breaks, burrs, rough spots, sharp edges, wear, or deterioration, damaged, loose, or missing nuts, bolts, screws, safety pins, or rivets, improper welding, or loss of spring tension.
  - b. Plastic and Wood. Inspect for bends, breaks, dents, holes, rough spots, sharp edges, and wear.
  - c. Cloth. Inspect for breaks, burns, cuts, frays, holes, rips, snags, or tears, loose, missing, or broken stitching or tacking, weak spots, wear, or deterioration.
  - d. Fabric Type, Webbing, and Cordage. Inspect for breaks, burns, cuts, frays, holes, snags, incorrect weaving, and sharp edges formed from searing, loose, missing, or broken stitching, tacking, shipping, and sealing, weak spots, wear, and deterioration.
  - e. Pressure Sensitive (Adhesive) Tape. Inspect for burns, cuts, holes, tears, and weak spots, looseness, and deterioration.
  - f. Rubber and Elastic. Inspect for burns, cuts, holes, tears, and weak spots, loss of elasticity, and deterioration.
  - g. Leather. Inspect for burns, cuts, holes, tears, loose, missing, or broken stitching, thin spots, and deterioration.

**ROUTINE INSPECTION**

A routine inspection is a visual check of the serviceability of all visible components of an airdrop item that is packed or rigged for use. The inspection will be made on all components that can be inspected without derigging the load. All LVADS Ancillary Equipment will be administered a routine inspection by a parachute rigger prior to issue.

## IN-STORAGE INSPECTION

An in-storage inspection is a physical check conducted on a random sample of airdrop equipment that is located in storage. The purpose of the inspection is to ensure that the equipment is ready for issue, that the item is properly identified and segregated from other types of equipment, that no damage or deterioration of equipment has been incurred, and that all modifications or similar action requirements have been completed. The inspection shall also concern the methods and procedures applied to the storage of airdrop items, the adequacy of storage facilities, efforts of pest and rodent control, and protection against unfavorable climatic conditions. Airdrop equipment that is in storage will be inspected at least semiannually and at more frequent intervals if prescribed by the local parachute maintenance officer. The frequency of inspection may vary according to the type of storage facilities and local climatic conditions. Only parachute rigger personnel designated by the local parachute maintenance officer will conduct in-storage inspections.

**Malfunctioning Equipment.** Dispose of any airdrop equipment that shows any evidence of malfunction or defect during or after a drop-test. If it has been used, is unserviceable, but has not exceeded normal fair wear or aging criteria, tag the equipment as prescribed in DA PAM 738-751. Report the equipment on an Equipment Improvement Report (EIR) in accordance with DA PAM 738-751 and AR 750-1. Hold the equipment as an EIR exhibit as outlined in DA PAM 738-750, pending receipt of disposition instructions from the National Maintenance Point (NMP). Do not tamper with the applicable item or make any attempt to discover the cause of the malfunction. Unnecessary handling of EIR equipment may hamper the judgment of the engineering personnel responsible for the final evaluation of EIR actions.

**Non-Malfunctioning Equipment.** Administer a technical/rigger-type inspection to equipment that does not show evidence of malfunction or defect, as outlined in this WP. If serviceable, the item (s) may then remain in use.

## EQUIPMENT DISPOSITION

Airdrop equipment may be rendered unserviceable by either normal fair wear or by aging and will subsequently be repaired, modified, or condemned, as appropriate. Equipment that is uneconomically repairable (outdated) will be condemned. Disposition of airdrop equipment that is condemned, unserviceable, or for which the serviceability is questionable, will be accomplished using the following procedures, as applicable.

1. Item requiring repair or modification. An airdrop item that requires repair or modification will be tagged in accordance with DA PAM 738-751. Subsequent work on the item will be performed at the maintenance level specified in the MAC, WP 0064 00.
2. Disposition of condemned air delivery equipment. Condemned equipment, other than fatality parachutes, will be removed from service and disposed of in accordance with current directives listed in this WP.
3. Rejected equipment. Equipment which, prior to use, is deemed unserviceable for use will be reported in an Equipment Improvement Recommendation (EIR) in accordance with DA PAM 738-751, as authorized by AR 750-1. Each applicable item that is defective will be held and safeguarded pending receipt of disposition instructions from the National Maintenance Point (NMP). In all instances, EIR exhibit material will be handled as prescribed in DA PAM 738-750. If the quality or the serviceability of an item is questionable, clarification and assistance may be obtained by contacting Commander, US Army Soldier and Biological Chemical Command, ATTN: AMSSB-RIM-E (N), Kansas Street, Natick, MA 01760-5052.

4. Equipment of doubtful serviceability. Equipment which has had previous use and has not exceeded normal fair wear or aging criteria, but of which further serviceability is doubtful, will be tagged as prescribed in DA PAM 738-751. In addition, the equipment will be reported in an EIR in accordance with DA Pam 738-750 and AR 750-1. The item (s) in question will be held as EIR exhibit material as outlined in DA PAM 738-750 pending receipt of disposition instructions from the NMP. A maintenance activity holding EIR exhibit material will not tamper with the applicable item(s) or make any attempt to ascertain cause factors. Unnecessary handling or EIR exhibit material may disturb or alter peculiar aspects of the affected item(s) which might affect the judgment of engineering personnel who have the responsibility for final evaluation of EIR actions.
5. Equipment immersed in salt-water. Any airdrop item constructed from cotton material that has been immersed in salt water will be condemned. Cotton thread used for tacking and sewing on nylon parachute packs that have been immersed in salt water will only be replaced when there is visible evidence of deterioration such as extreme discoloration or indications of broken thread. Any airdrop equipment constructed of nylon or rayon material that has been immersed in salt water in excess of 24-hours will be condemned. Additionally, any nylon or rayon airdrop item that has been immersed in salt water for a period less than 24-hours, but which cannot be rinsed within 48-hours after recovery will also be condemned. However, if the cited time limitations can be met, then immediately upon recovery, suspend or elevate the recovered equipment in a shaded area and allow the item(s) to drain for at least 5-minutes. Do not attempt to wring the equipment fabric or the suspension lines. Within 48-hours after recovery, under the supervision of a qualified parachute rigger (92R), rinse the recovered equipment as indicated in WP 0008 00, CLEANING AND DRYING.

**END OF WORK PACKAGE**



---

**UNIT MAINTENANCE  
ANCILLARY EQUIPMENT FOR LOW VELOCITY AIR DROP SYSTEMS (LVADS)  
CLEANING AND DRYING**

---

**THIS TASK COVERS:**

- Cleaning Fabric Items With Dishwashing Compound
  - Drying Fabric Items
  - Cleaning Metal Items
  - Rinsing Equipment Immersed in Salt-water
  - Rinsing Equipment Immersed in Fresh-water
- 

**INITIAL SETUP:****Materials/Parts**

Cloth, Abrasive (Item 6, WP 0125 00)  
Dishwashing Compound (Item 10, WP 0125 00)  
Lubricant, Solid Film (Item 20, WP 0125 00)  
Rag, Wiping (Item 25, WP 0125 00)

**Tools**

Brush, Scrub, Household (Item 2, WP 0064 00)  
File, Flat (Item 10, WP 0064 00)

**Equipment Condition**

Laid out on packing table or other suitable surface.

**Personnel Required**

Two, 92R (10) Parachute Rigger

**References**

WP 0003 00, WP 0007 00, WP 006400

---



---

**CAUTION**

---

If, during the cleaning, there exists a possibility that the substance to be removed contains acid or some other equally destructive ingredient, the item will be evacuated to intermediate maintenance activity for determination as to the nature of the substance and item disposition. If the substance cannot be identified or if normal repair procedures will not eliminate all traces of chemical or acid damage, the applicable item will be condemned.

---

**NOTE**

---

Cleaning of materials should be held to a minimum and should be performed only when necessary to prevent malfunction or deterioration. When a material contains debris, or when it is soiled by dirt, oil, grease, rust, corrosion, or other foreign substances to such an extent that cleaning is necessary, the cleaning should be performed manually and should be limited to the soiled area only, unless the materials has been contaminated by water. The methods of cleaning must be determined by the nature of the substance to be removed.

**CLEANING FABRIC ITEMS WITH A SOLUTION OF HAND DISHWASHING COMPOUND**

Use dishwashing compound to clean fabric items as follows:

1. Gently brush with a soft bristle brush.
2. Spot clean with a solution of dishwashing compound.

- a. Dissolve one-half cup of dishwashing compound in one-gallon of warm water.
- b. Rub soiled area with a clean cloth dampened with solution of dishwashing compound.
- c. Rinse cleaned area by repeating rubbing process with a clean portion of cloth dampened with fresh, clean water.

**NOTE**

Do not dry fabric items in direct sunlight or by laying an item on the ground.

### **DRYING FABRIC ITEMS**

Dry fabric items as follows:

1. Suspend or elevate item in a well-ventilated room or in a heated drying room.
2. Using electric circulating fans may reduce drying time.
3. When heat is used, the heat temperature shall not exceed 160°F (71°C). Preferred temperature is 140°F (60°C).

### **CLEANING METAL ITEMS**

Clean metal items as follows:

**CAUTION**

Use care not to damage the adjacent fabric materials.

1. Remove burrs, rough spots, rust or corrosion from metal items by filing with a metal file or by buffing and polishing with abrasive cloth.

**NOTE**

Shield adjacent fabric material before spraying solid film lubricant.

2. Spray metal item with a solid film lubricant and allow to air dry for 24-hours.

---

**NOTE**

---

A small amount of lubricant will not damage fabric, but may cause discoloration and make fabric appear soiled.

**RINSING EQUIPMENT IMMERSSED IN SALT-WATER**

If the fabric item, or any of its components, has been immersed in salt-water in excess of 24-hours it will be condemned. Additionally, if the fabric item, or any of its components, has been immersed in salt-water for a period less than 24-hours, but cannot be rinsed within 48-hours after recovery, it will also be condemned. However, if the cited time limitations can be met, then immediately upon recovery, suspend or elevate the item in a shaded area and allow it to drain for at least 5-minutes. Do not attempt to wring the fabric. Within 48-hours after recovery, under the supervision of a qualified parachute rigger (92R); rinse the item. Items found, or known to be contaminated, are to be cleaned in the following manner:

1. Place equipment in a large watertight container filled with a suitable amount of fresh, clean water to cover item(s).

---

**CAUTION**

---

Equipment made of cotton fabric immersed in salt-water is to be condemned. Refer to WP 0007 00, INSPECTION, for equipment disposition.

---

**NOTE**

---

If salt water-soaked equipment is too large to be placed in a rinsing container, then the rinsing process will be affected by applying fresh, clean water using a hose on the item.

2. Agitate container contents by hand for 5-minutes.
3. Remove item(s) from container and suspend or elevate equipment in a shaded area, allowing a 5-minute drainage period. Do not attempt to wring equipment fabric or, if applicable, suspension lines.
4. Repeat procedures 1. through 3., above, twice, using fresh, clean water for each rinse.
5. After third rinse, allow equipment to drain thoroughly. Upon completion of draining, dry equipment in accordance with the DRYING FABRIC ITEMS procedures detailed above.
6. When dried, perform a technical/rigger-type inspection of item(s). Corroded metal components, or corrosion-stained fabrics or suspension lines will be either repaired or replaced as prescribed by the MAC, WP 0064 00.
7. If recovered equipment is a parachute, record immersion, rinsing, and any repairs in individual parachute log record as detailed in WP 0003 00 (SERVICE UPON RECEIPT).

**RINSING EQUIPMENT IMMERSSED IN FRESH-WATER**

Any airdrop equipment that has been immersed in a fresh-water lake, river or stream will not require rinsing unless it has been ascertained that the water is dirty, oily or otherwise contaminated. Procedures for handling fresh-water immersed equipment are as follows:

1. Contaminated fresh-water. If the airdrop equipment has been immersed in contaminated fresh-water, rinse, dry and, if applicable, repair the item(s) using the procedures in the RINSING EQUIPMENT IMMERSSED IN SALT-WATER paragraph.
2. Uncontaminated fresh-water. If airdrop equipment has been immersed in uncontaminated fresh-water, item(s) will be cleaned and dried as outlined in this paragraph. Minor discoloration of fabric items resulting from immersion in uncontaminated fresh-water may occur. No attempt should be made to eliminate a minor discoloration, as a slight discoloring is preferable to employing vigorous techniques that may damage fabric.

**END OF WORK PACKAGE**

---

**UNIT MAINTENANCE  
ANCILLARY EQUIPMENT FOR LOW VELOCITY AIR DROP SYSTEMS (LVADS)  
SALT-/FRESH-WATER CONTAMINATION TEST**

---

**THIS TASK COVERS:**

- Inspection
- 

**INITIAL SETUP:**

**Equipment Condition**

Laid out on packing table or other suitable surface.

**References**

WP 0003 00; WP 0007 00; WP 0064 00

**Personnel Required**

Two, 92R (10) Parachute Rigger

---

**INSPECTION**

Look for a white crystalline residue. If evidence of salt-/fresh-water contamination is found, refer to the procedures detailed below:

**Rinsing Equipment Immersed in Salt-Water.** If the fabric items, or any of its components, has been immersed in salt-water in excess of 24-hours it will be condemned. Additionally, if the fabric items, or any of its components, has been immersed in salt-water for a period less than 24-hours, but cannot be rinsed within 48-hours after recover, it will also be condemned. However, if the cited time limitations can be met, then immediately upon recovery, suspend or elevate the fabric items in a shaded area and allow it to drain for at least 5-minutes. Do not attempt to wring the fabric. Within 48-hours after recovery, under the supervision of a qualified parachute rigger (92R), rinse the recovered items. Items found or known to be contaminated are to be cleaned in the following manner:

1. Place equipment in a large watertight container filled with a suitable amount of fresh, clean water to cover item(s).

---

**CAUTION**

---

Equipment made of cotton fabric immersed in salt-water is to be condemned. Refer to WP 0007 00, INSPECTION, for equipment disposition.

---

**NOTE**

---

If salt water-soaked equipment is too large to be placed in a rinsing container, then the rinsing process will be affected by applying fresh, clean water using a hose on the item.

2. Agitate container contents by hand for 5-minutes.
3. Remove item(s) from container and suspend or elevate equipment in a shaded area, allowing a 5-minute drainage period. Do not attempt to wring equipment fabric.
4. Repeat procedures 1. through 3., above, twice, using fresh, clean water for each rinse.

5. After third rinse, allow equipment to drain thoroughly. Upon completion of draining, dry equipment in accordance with the DRYING FABRIC ITEMS procedures detailed above.
6. When dried, perform a technical/rigger-type inspection of item(s). Corroded metal components, or corrosion-stained fabrics or suspension lines will be either repaired or replaced as prescribed by the MAC, WP 0064 00.
7. Record immersion, rinsing, and any repairs in individual parachute log record as detailed in WP 0003 00 (SERVICE UPON RECEIPT).

**Equipment Immersed in Fresh-Water.** Any airdrop equipment that has been immersed in a fresh-water lake, river or stream will not require rinsing unless it has been ascertained that the water is dirty, oily or otherwise contaminated. Procedures for handling fresh-water immersed equipment are as follows:

1. Contaminated fresh-water. If the airdrop equipment has been immersed in contaminated fresh-water, rinse, dry and, if applicable, repair the item(s) using the procedures in the RINSING EQUIPMENT IMMERSSED IN SALT-WATER paragraph.
2. Uncontaminated fresh-water. If airdrop equipment has been immersed in uncontaminated fresh-water, item(s) will be cleaned and dried as outlined in this paragraph. Minor discoloration of fabric items resulting from immersion in uncontaminated fresh-water may occur. No attempt should be made to eliminate a minor discoloration, as a slight discoloring is preferable to employing vigorous techniques that may damage fabric.

**END OF WORK PACKAGE**

---

**UNIT MAINTENANCE  
ANCILLARY EQUIPMENT FOR LOW VELOCITY AIR DROP SYSTEMS (LVADS)  
SEWING PROCEDURES**

---

**THIS TASK COVERS:**

- Basting and Temporary Tacking
  - Stitching and Restitching
  - Darning
  - Zig-Zag Sewing
- 

**Tools**

Specified in paragraph applicable to the item being repaired.

**Personnel Required**

92R (10) Parachute Rigger

**Materials/Parts**

Specified in paragraph applicable to the item being repaired.

**Equipment Condition**

Unpacked. Cleaned canopy with defects recorded.

**References**

DA PAM 738-751; WP 0011 00

---

---

**NOTE**

---

Sewing requirements will vary according to the type of item being repaired and the type of repair being made. The type of sewing machine, type of thread, the stitch range, and the stitch pattern, if applicable, required to accomplish a sewing procedure will be specified in the paragraph applicable to the item being repaired. All original stitching that is cut during the performance of a sewing procedure will be removed from the applicable item. Immediately after the accomplishment of a machine sewing procedure, trim thread ends to a point as close as possible to the material that has been sewn.

**BASTING AND TEMPORARY TACKING**

Basting and temporary tacking are hand-sewing methods used to temporarily hold layers of cloth fabric together while a repair is being performed. The following is a list of procedures that apply to basting and temporary tacking actions:

1. Basting and temporary tacking should be made using thread that is of a contrasting color to the material being worked.
2. Basting will be done using thread identified in individual item repair procedure.
3. When basting, do not tie knots at any point in the thread length. Also, the sewing should be done with two stitches per inch.
4. Temporary tacking will usually be done using a length of size E nylon thread (Item 32, WP 0125 00). However, an alternate type thread may be specified within the paragraph applicable to the item.
5. Immediately upon completion of a repair, remove previously made basting or temporary tacking stitches.

**STITCHING AND RESTITCHING**

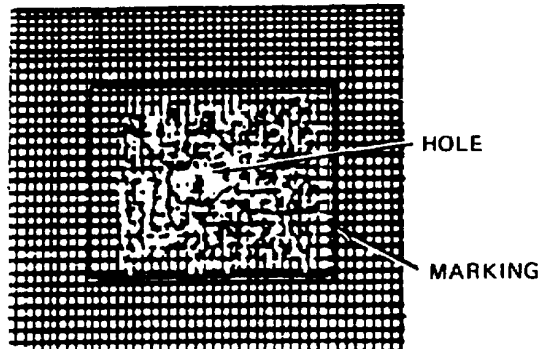
Perform stitching and restitching as follows, referring to Table 1:

**Table 1. Sewing Machine Code Symbols**

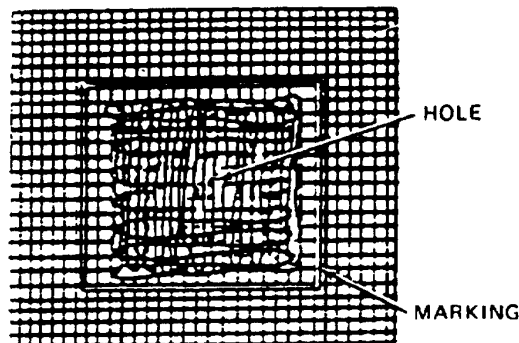
CODE SYMBOL	SEWING MACHINE
LD	SEWING MACHINE, INDUSTRIAL: General sewing; 301 stitch; light-duty; NSN 3530-01-177-8590.
MD ZZ	SEWING MACHINE, INDUSTRIAL: Zig-zag; 308 stitch; medium-duty; NSN 3530-01-181-1421.
LD ZZ	SEWING MACHINE, INDUSTRIAL: Zig-zag; 308 stitch; light-duty; NSN 3530-01-181-1420.
HD	SEWING MACHINE, INDUSTRIAL: General sewing; 301 stitch; heavy-duty; NSN 3530-01-177-8588.
MD	SEWING MACHINE, INDUSTRIAL: General sewing; 301 stitch; medium-duty; NSN 3530-01-177-8591.
DN	SEWING MACHINE, INDUSTRIAL: Darning; lock stitch; NSN 3530-01-177-8589.
LHD	SEWING MACHINE, INDUSTRIAL: 301 stitch; light, heavy-duty; NSN 3530-01-186-3079.
ND	SEWING MACHINE, INDUSTRIAL: 301 stitch; double needle; NSN 3530-01-182-2873.
BT	SEWING MACHINE, INDUSTRIAL: Bartack, 42 stitch (local purchase)



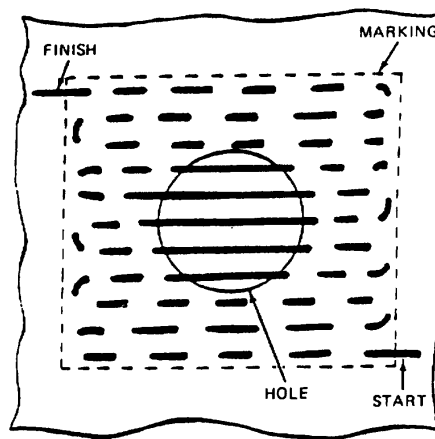
1. Stitching and restitching on items constructed from cloth, canvas, and webbing should be accomplished with thread that matches the color of the original stitching, when possible. Backstitching at least  $\frac{1}{2}$ -inch should lock all straight stitching. Restitching should be locked by overstitching each end of the stitch formation by  $\frac{1}{2}$ -inch. Zig-zag stitching does not require locking; however, zig-zag restitching should extend at least  $\frac{1}{4}$ -inch into undamaged stitching at each end, when possible. Restitching should be made directly over the original stitching, following the original stitch pattern as closely as possible.
2. Darning. (Refer to Table 1.) Darning is a sewing procedure used to repair limited size holes, rips, and tears in assorted airdrop items constructed from textile, cloth and reinforcement webbing of packs. A darning repair may be made either by hand or sewing machine, depending upon the method preferred and the availability of equipment. However, a darning machine should be used to darn small holes and tears where fabric is missing. Darning of previously patched material can be performed provided darning size limitations prescribed in the paragraph applicable to the item are not exceeded. A darning repair will be performed using the following procedures, as appropriate:
  - a. Machine darning. Proceed as follows:
    - (1) Using an authorized marking aid of contrasting color, mark a square around the damaged area and ensure that the marking is at least  $\frac{1}{4}$ -inch back from each edge of the damaged area. The marking will be made with the warp and the filling of the material.
    - (2) Darn the damaged area by sewing the material in a back-and-forth manner, using size A or E nylon thread, allowing the stitching to run with the warp or filling of the fabric.



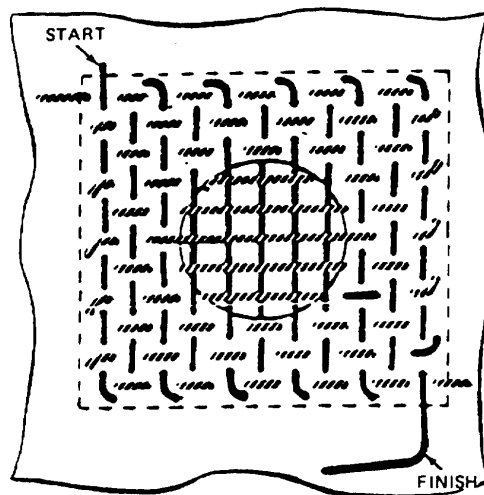
- (3) Turn the material and stitch back and forth across the stitching made in (b) above until the hole or tear is completely darned.



- (4) If applicable, restencil informational data, gore number(s), or identification marks using the criteria in WP 0011 00, MARKING, RESTENCILLING AND REPAINTING.
- b. Hand darning. When repair of a hole or tear is made by hand darning, the darn should match the original weave of the damaged material as closely as possible. Hand darning will be performed as follows:
- (1) Using an authorized marking aid of contrasting color, mark a square around the damaged area and ensure that the marking is at least ¼-inch back from edge of the damaged area. The marking will be made with the warp and the filling of the material.
  - (2) Using a darning needle and a length of size A or E nylon thread, begin darning at one corner of the marked area. Working in the direction of the fabric warp or filling, pass the needle and thread back and forth, through the material until the opposite diagonal corner of the marked area is reached.



- (3) Turn the material and weave the needle and thread back and forth across the stitching made in (b), above, until the hole is completely darned.



(4) If applicable, restencil informational data or identification marks as outlined in WP 0011 00, MARKING, RESTENCILLING AND REPAINTING.

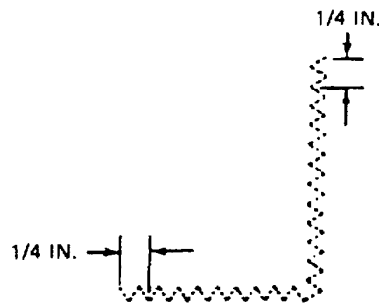
3. Zig-Zag Sewing. (Refer to Table 1 and Table 2.) Airdrop items, except parachute canopies, made from textile materials that have sustained cut or tear damage may be repaired by zig-zag sewing provided the applicable damaged area does not have any material missing and the cut or tear is straight or L-shaped. Should the damaged area be irregular shaped or have material missing, the repair will be achieved by either darning or patching, as required. A zig-zag sewing repair will be accomplished with a zig-zag sewing machine, using the following procedures:

- a. Set the sewing machine to the maximum stitch width.
- b. Beginning at a point ¼-inch beyond one end of the cut or tear, stitch lengthwise along the damaged area to a point ¼-inch beyond the opposite end of the cut or tear.



**STRAIGHT CUT OR TEAR STITCHING**

- c. The cited stitching procedure will also apply to an L-shaped cut or tear.



**L-SHAPED CUT OR TEAR STITCHING**

- d. If applicable, restencil informational data or identification marks as prescribed in WP 0011 00, MARKING, RESTENCILLING AND REPAINTING.

**END OF WORK PACKAGE**



---

**UNIT MAINTENANCE  
ANCILLARY EQUIPMENT FOR LOW VELOCITY AIR DROP SYSTEMS (LVADS)  
MARKING, RESTENCILING, AND REPAINTING**

---

**THIS TASK COVERS:**

- Marking
  - Restenciling
  - Remarking and Restenciling
- 

**Tools**

Brush, Stenciling (Item 3, WP 0064 00)  
Knife (Item 17, WP 0064 00)  
Machine, Stencil Cutting (Item 20, WP 0065 00)

**Materials/Parts**

Ink, Marking, Parachute, Strata-Blue (Item 14, WP 0125 00)  
Marker, Felt Tip, Black (Item 21, WP 0125 00)  
Pen, Ballpoint (Item 24, WP 0125 00)  
Stencilboard, Oiled (Item 26, WP 0125 00)

---

**Personnel Required**

92R (10) Parachute Rigger

**Equipment Condition**

Laid out on packing table or other suitable area.

---

**NOTE**

---

Stenciling should be used whenever possible. A ballpoint pen or felt tip marker should be used only where stenciling is not possible, or when stenciling devices are not available. Any type ballpoint pen using black or blue ink may be used for marking on labels only. Original stenciled data or marking that becomes faded, illegible, obliterated, or removed as a result of performing a repair procedure will be remarked with a ballpoint pen, felt tip marker, or restenciled. All marking or restenciling will be done on, or as near as possible to, the original location and should conform to the original lettering type and size.

**MARKING**

Using marking devices, such as ballpoint pen or felt tip marker, mark on, or as near as possible to, original location and conform to original lettering type and size.

**RESTENCILING**

Proceed as follows:

1. Cut oiled stencilboard to original lettering type and size of data to be restenciled.
2. Place cut stencilboard over, or as near as possible to, original marking to be restenciled.
3. Place additional sheet of stencilboard beneath the area to be restenciled to prevent the marking ink from penetrating to the areas.
4. Hold stencilboard in place and, using stenciling brush filled with parachute marking ink, restencil original marking.

**REMARKING AND RESTENCILING**

Remark or restencil original stenciled data or markings that become faded, illegible, obliterated or have been removed as a result of performing a repair procedure. Ensure all marking or restenciling is on, or as near as possible to, the original location and conforms to the original lettering type and size. Airdrop items that are fabricated, altered, or modified by directive publications may require the placement of other markings by the original marking or stenciling. Use a contrasting color of parachute marking ink.

**NOTE**

Stenciling should be used whenever possible. A ballpoint pen or felt tip marker should be used only where stenciling is not possible. Any type of ballpoint, either black or blue, ink may be used for marking labels.

**REPAINTING**

Repaint any warning mark on airdrop equipment that is chipped or worn with red enamel paint using a proper size paintbrush. Repaint with original color enamel any mark previously painted on an airdrop item to signify satisfactory completion of a test, providing the item is still serviceable. Metal items may be repainted with olive drab paint.

**END OF WORK PACKAGE**

---

**UNIT MAINTENANCE**  
**ANCILLARY EQUIPMENT FOR LOW VELOCITY AIR DROP SYSTEMS (LVADS)**  
**MULTI-LOOP LINE**

---

**THIS TASK COVERS:**

- Inspect
  - Repair
  - Replace
- 

**Tools**

Knife, Pocket (Item 19, WP 0064 00)  
Shear, Trimmer (Item 41, WP 0064 00)

**Materials/Parts**

Beeswax (Item 3, WP 0125 00)  
Line, Multi-Loop (Item 2, WP 01066 00)  
Tape, Pressure Sensitive, Type IV (Item 30, WP 0125 00)  
Thread, Nylon, Size 6, OD (Item 31, WP 0125 00)  
Thread, Nylon, Size FF, OD (Item 33, WP 0125 00)  
Wax, Paraffin, Technical, Type I, Grade A (Item 34, WP 0125 00)  
Webbing, Nylon, Type VIII (Item 36, WP 0125 00)  
Webbing, Nylon, Type XXVI (Item 37, WP 0125 00)

---

**Personnel Required**

92R (10) Parachute Rigger

**Equipment Condition**

Fully Assembled.

**References**

WP 0005 00; WP 0007 00; WP 0010 00

---

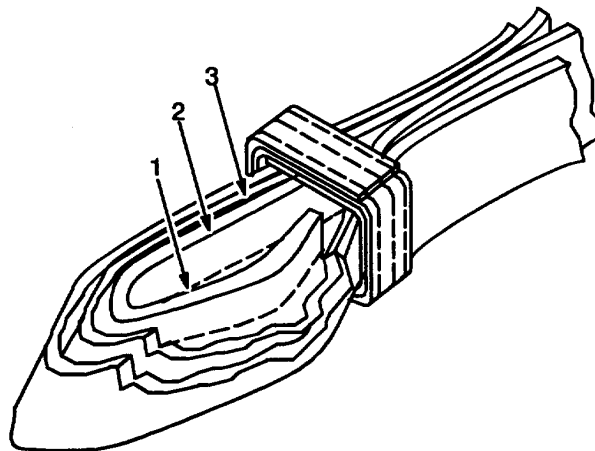
**INSPECT**

Perform a technical/rigger-type inspection of the multi-loop line including buffer, sliding keeper, and fixed keepers in accordance with WP 0007 00 and WP 0005 00 using the procedures in Table 1.

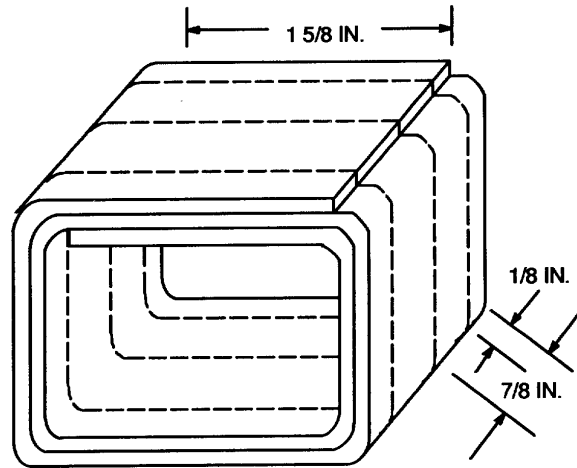
**REPAIR**

Repair sliding or fixed keepers as described below.

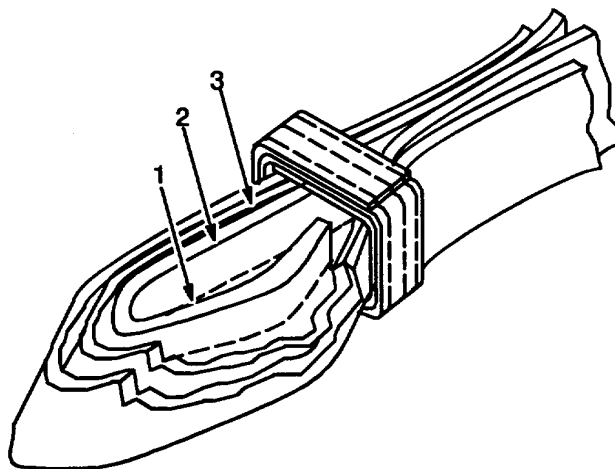
1. Sliding Keeper.
  - a. Cut the stitching securing the buffer (2) to inside loop (3) and remove buffer (2).
  - b. Slide the defective keeper off the multi-loop line.



- c. Cut a length of type VIII nylon webbing long enough to form two turns around the sling and allow for a  $1\frac{5}{8}$ -inch overlap.
- d. Stitch  $\frac{1}{8}$ -inch (3 millimeter) from each edge of keeper material around each end of the keeper with size 6 thread, using HD sewing machine 5 to 8 stitches per inch (2 to 3 stitches per cm).
- e. Wax the entire keeper and allow it to cool. Dip the keeper into a mixture of 50% paraffin wax and 50% beeswax. The wax temperature should be high enough to ensure that the wax completely penetrates the material rather than just coating the exterior fabric ( $180^{\circ} \pm 20^{\circ}\text{F}$  ( $82^{\circ} \pm 11^{\circ}\text{C}$ )).

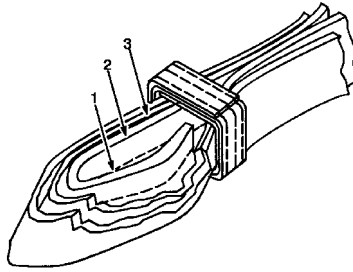


- f. Slide the fabricated keeper onto the line.
- g. Fold buffer in half and insert into loop (3). Offset buffer ends by 1-inch (2.5 cm).





- h. Using HD sewing machine and 8 to 11 stitches per inch (3 to 4 stitches per cm), stitch buffer (2) to inside loop (3) with size FF thread (1) longitudinally along the centerline. Stitch 1-inch (2.5 cm) beyond buffer with no backstitch.

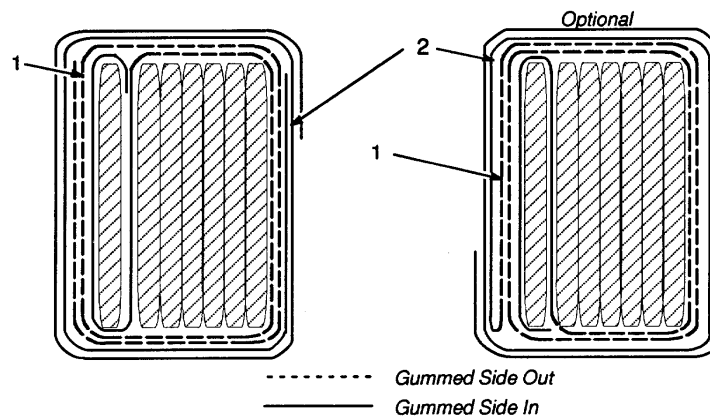


2. Fixed Keeper.

- a. Remove unserviceable fixed keeper by peeling off the tape (1), using care not to damage the webbing.



- b. Using type IV pressure sensitive tape, starting on an outer ply, wrap the first tape strip (1) around this ply with the gum side against the webbing.
- c. Wrap tape (1) around the outside of all plies for two full turns with the gummed side away from the webbing.
- d. Cut the tape or, (optional method), fold it over gum-side to gum-side.
- e. Wrap tape (2) in the opposite direction two full turns with the gum side toward the previous wraps.
- f. Cut tape (2).



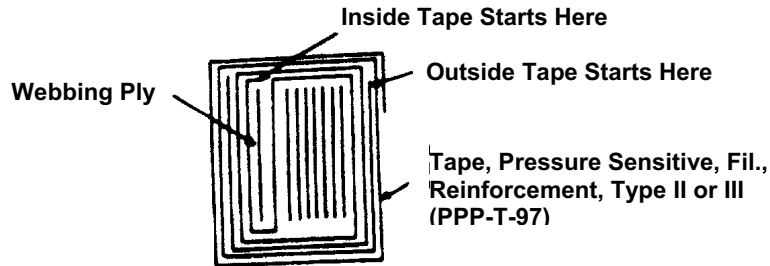
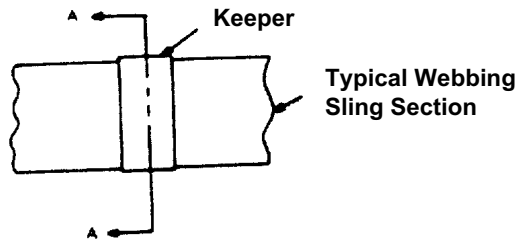
3. Splicing Type XXVI Nylon Webbing. Splice a cargo sling or extraction line as follows:

**NOTE**

Splicing may be performed on the webbing loops of all lines and slings, except the 3-foot sling, to repair damage areas. Three splices per loop are permitted on lines less than 20-feet in length. Four splices per loop are permitted on lines 20 to 60-feet in length. Five splices per loop are permitted on lines longer than 60-feet. The total number of splices permitted per loop includes the original loop connector splice.

**NOTE**

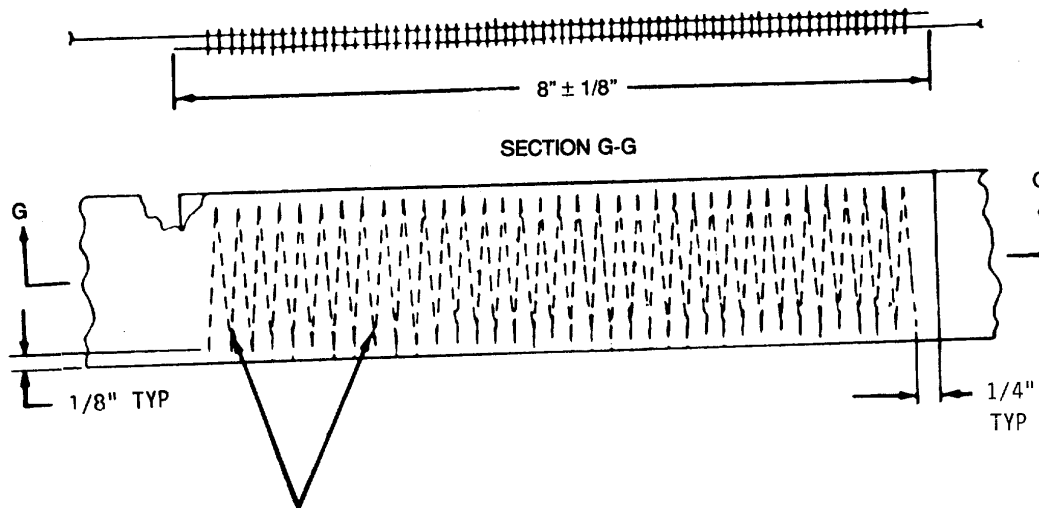
Splicing shall not be performed when a damaged areas is less than 24-inches from another splice. A splice may extend to a point no closer than 12-inches from a webbing loop end. The original webbing loop connector splice may be cut if it is damaged or directly adjacent to a damaged area. Splices will be centered between fixed keepers.



Section A-A Not To Scale

- a. If an inside loop within 12-inches of the loop end is being spliced, cut the tacking which secures the buffer at each end and remove the buffers temporarily. Adjust the inside loop so the splice will not be within 12-inches of the webbing loop end. Insure the splice will not be centered under the keeper loops.

- b. Replace Buffers. Cut a 20-inch length of type XXVI nylon webbing and wax the ends. Offset buffer ends 1-inch. Stitch to inside loop longitudinally down webbing centerline, one row of stitching using size FF thread, 1-inch beyond end of buffer, no backstitch.
- c. Cut the webbing on both sides of damaged area with cuts between fixed keepers. Remove fixed keepers from portion of loop to be replaced. Remove damage webbing. Sear the edges of the webbing ends of the remaining loop.
- d. Cut a length of type XXVI nylon webbing the length of the damaged webbing that was removed, adding an additional 16  $\frac{1}{4}$ -inches for splice allowance. Sear both ends.
- e. Position one end of the new webbing on the outside of one end of the remaining loop so that it overlaps 8  $\frac{1}{8}$ -inches.
- f. Sew 72  $\pm$  5 lines of stitching using size 5 thread 4 to 6 stitches per inch, using the stitch formation shown in the illustration below. Size 6 thread may be used if size 5 thread is unavailable. Stitching shall be performed according to WP 0010 00, SEWING PROCEDURES, using specifics in Table 1.



- g. Repeat steps e. and f. with the other end of the new webbing and the remaining loop end.
- h. Replace fixed keepers.

### REPLACE

Replace unserviceable multi-loop line with a serviceable one from stock.

**END OF WORK PACKAGE**



---

**UNIT MAINTENANCE  
ANCILLARY EQUIPMENT FOR LOW VELOCITY AIR DROP SYSTEMS (LVADS)  
EXTRACTION FORCE TRANSFER COUPLING**

---

**THIS TASK COVERS:**

- Inspect
  - Repair
  - Replace
- 

**Tools**

Brush, Scrub, Household (Item 2, WP 0064 00)  
 File, Bastard (Item 8/9, WP 0064 00)  
 Knife (Item 17, WP 0064 00)  
 Straight Edge, 2-IN. (Item 45, WP 0064 00)  
 Tape Measure (Item 46, WP 0064 00)  
 Wrench, Open End, 1 <sup>1</sup>/<sub>16</sub>-IN. and 1 <sup>1</sup>/<sub>8</sub>-IN. (Item 54, WP 0064 00)  
 Wrench, Open End, 1 <sup>1</sup>/<sub>4</sub>-IN. and 1 <sup>5</sup>/<sub>16</sub>-IN (Item 52, WP 0064 00)  
 Wrench, Open End, 1 <sup>7</sup>/<sub>16</sub>-IN. and 1 <sup>5</sup>/<sub>8</sub>-IN (Item 56, WP 0064 00)  
 Wrench, Open End, <sup>7</sup>/<sub>16</sub>-IN. (Item 50, WP 0064 00)

**Materials/Parts**

Coupling, Extraction Force Transfer (WP 0067 00)  
 Paint, Yellow Enamel (Item 23, WP 0125 00)  
 Pen, Ballpoint (Item 24, WP 0125 00)  
 Rag, Wiping (Item 25, WP 0125 00)

**Personnel Required**

92R (10) Parachute Rigger

**Equipment Condition**

Fully Assembled.

**References**

WP 0005 00; WP 000800; WPs 0013 00 – 0019 00;  
 WPs 0068 00 – WP 0073 00

---

**INSPECT**

Inspect the components of the coupling extraction force transfer in accordance with WP 0005 00 using the procedures in Table 1.

**REPAIR**

Disassemble Extraction Force Transfer Coupling (EFTC) as follows:

1. Remove cable assembly **(2)** from actuator **(1)** and latch assembly **(7)** as follows:
  - a. Remove the locking pin **(3)** securing the housing cover to the actuator assembly and hinge the cover open.

---

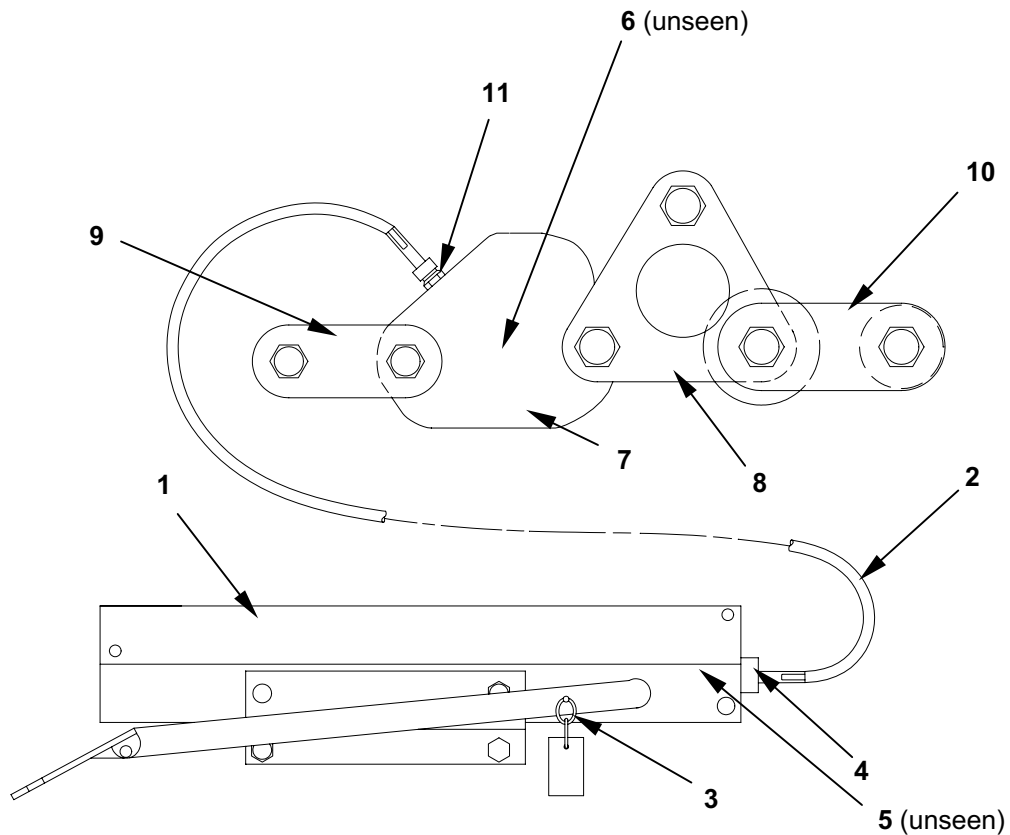
**CAUTION**

---

The stake assembly-adjusting collar (on the cable assembly) is preset and staked by four setscrews. The collar position shall not be altered at any time or under any condition.

- b. Using a suitable tool, loosen the locking nut **(4)** securing the cable assembly **(2)** housing to the actuator assembly **(1)**. Ensure the adjusting collar on the cable assembly is not disturbed during the cable removal process.
- c. Remove the cotter pin and straight pin **(5)** securing the cable end clevis to the cable actuator and remove the cable assembly from the actuator assembly.

- d. Using a suitable tool, loosen the nut (11) securing the cable assembly (2) housing to the latch assembly (7). Disconnect the cable-swaging terminal (6) from the latch assembly (7) by removing the straight-headed pin and the ½-inch (1.2 cm) long cotter pin.
2. Remove 3-point link assembly (8) from latch assembly and remove latch connector assembly (9) and link assembly adapter (10) from link assembly as follows:
    - a. Using a suitable tool, disassemble the 3-point link (8) by removing the three 1-inch hexagon jam nuts, the three 1-inch hexagon cap screws, the two spacers, and the single cam from the two 3-point link assembly side plates.
    - b. Using a suitable tool, disassemble the latch connector assembly (9) removing the 1-inch hexagon jam nut and 1-inch hexagon cap screw from the opposite side of the latch assembly and remove both side plates.
    - c. Using a suitable tool, remove the remaining 1-inch hexagon jam nut and 1-inch hexagon cap screws securing the side plates of the link assembly adapter (10).



3. Clean each component as follows:
  - a. Use the procedures in WP 0008 00.
  - b. In addition, remove dirt and other foreign matter from a component by shaking or brushing, as required.
  - c. If necessary, remove dirt and debris from inaccessible locations using a compressed air hose.

4. Reassemble link assembly as follows:
  - a. Reassemble the 3-point link assembly (8) by securing the side plates of the link assembly adapter (10) to the 3-point link assembly and connecting the three 1-inch hexagon jam nuts, the three 1-inch hexagon cap screws, the two spacers, and the single cam from the two 3-point link assembly side plates.
  - b. Connect the cable-swaging terminal (6) to the latch assembly (7) by installing the straight-headed pin and the ½-inch (1½-cm) long cotter pin from top to bottom.
  - c. To join the cable assembly (2) to the actuator assembly (1), install the cotter pin and straight pin securing the cable end clevis to the cable actuator.

**CAUTION**

The stake assembly-adjusting collar is preset and staked by four setscrews. The collar position will not be altered at any time or under any condition.

- d. Using a suitable tool, tighten the locking nut securing the cable assembly (2) housing to the actuator assembly (1). Ensure that the adjusting collar on the cable assembly is not disturbed during the cable attaching process.
- e. Install the locking pin securing the housing cover to the actuator assembly and shut the cover.
- f. Using a suitable tool, connect both side plates of the latch connector assembly (9) to the latch by connecting the 1-inch hexagon jam nut and 1-inch hexagon cap screw from the underside of the latch assembly.
- g. Attach the 3-point link assembly (8) to the latch assembly (7) by properly seating the cam of the link within the latch assembly.
- h. Once fully assembled, the following procedures must be accomplished before each use. With the EFTC mounted (preferably on a platform), proceed as follows:

**NOTE**

When attaching the latch assembly to the modified extraction lug on the Type V Platform, the four aluminum latch assembly adapter spacers are not required. The modified extraction lugs are identified by the presence of a ½-inch steel strip welded to the lower flat surface of the extraction lug.

- i. Rotate actuator arm clockwise until spring guide rod is fully extended.
- j. Lock the actuator arm into position with the appropriate quick release pin.
- k. Place a 2-inch straight edge (or equivalent) on the fork end of the spring guide rod.
- l. If spring guide rod shows any bend or curvature against straight edge, remove EFTC from service.

5. Check for Free Movement of Actuator Arm Latching Pin as follows:
  - a. Pull latch ring on side of actuator to determine if latch pin moves freely under force of latch spring.
  - b. Slowly rotate actuator arm counterclockwise to ensure arm pushes in latch pin and latch pin snaps back into position to secure from rotating clockwise.
  - c. If latch pin sticks in one position, check for binding, bends, dirt, or debris on the latch pin assembly inside actuator. Remove dirt and foreign matter but if pin is bent, remove EFTC from service.
6. Tighten three (3) self-locking nuts on 3-point link assembly as follows:
  - a. Using a suitable tool, tighten all three self-locking nuts whereby, two (2) threads of bolt extend past end of nut. Do not over tighten nuts.
  - b. If length of thread does not allow for the above procedures, tighten nut whereby end of bolt is flush with end of nut.
7. Check for a Misaligned Dot and Arrow as follows:
  - a. If dot and arrow are not aligned within a  $\frac{1}{16}$ -inch, check that lock link is fully seated into catch slot so catch is completely bottomed over lock link.
  - b. If latch is properly seated but dot and arrow remain misaligned more than a  $\frac{1}{16}$ -inch, the latch must be identified for continued use and inspections.
    - (1) Stencil a  $\frac{1}{2}$ -inch capital letter I on each side plate using yellow enamel paint.
8. Check Cam of 3-Point Link and Latch for Proper Seating as follows:
  - a. Check alignment of dot and arrow as per instructions above.
  - b. If cam cannot be locked into a latch, repeat test procedure using other cam and latch combinations.
  - c. If cam cannot be locked, remove from service. If properly seated, ensure cable is properly connected to latch and actuator.
9. If positive lock is felt more than  $\frac{1}{16}$ -inch from the position of alignment between the visual dot and arrow when thumb pressure is exerted on the latch. Check actuator as follows:
  - a. Disconnect cable from actuator end.
  - b. Rotate arm of actuator to locking position and insert pin to hold arm.
  - c. Check locking position of actuating link at cable hole connecting point. Measure the distance between the center of the hole to the outside end of the actuator housing from which cable extends.
  - d. If measured distance does not exceed 2  $\frac{1}{2}$ -inches, the cable is adjusted incorrectly. Do not use cable.
  - e. If the measured distance exceeds 2  $\frac{1}{2}$ -inches, the actuator arm/shaft is improperly fabricated and will not provide adequate cable locking stroke. Do not use actuator.
10. Check EFTC for Positive Lock and Operation as follows:



- a. Check the EFTC for positive lock pressure by applying moderate thumb pressure on the catch toward the cable, attempting to lift the catch open.
- b. If the catch can be moved  $\frac{1}{16}$  of an inch the internal cable positive lock is improperly set.
- c. Recheck the actuator for the 2  $\frac{1}{2}$ -inch dimension as described above. If actuator is found suitable, then cable assembly collar is set incorrectly and is defective, remove cable from service.
- d. If the catch cannot be moved  $\frac{1}{16}$  of an inch under moderate thumb pressure, and catch returns to seated position (dot and arrow aligned), then EFTC is properly locked.
- e. Check that actuator arm swings freely through the platform rail indents with no interference from the hex head bolts (replaced by round head bolts IAW FM 4.20-102) or other parts of platform. This includes the upswing of arm to horizontal locked position by spring lever in actuator body.
- f. Check for proper operation of the EFTC by removing the actuator body from the EFTA mounting brackets after removing the actuator pins.
- g. Carefully remove the actuator arm-locking pin and slowly rotate arm through its full range of motion. Check that the catch in the latch was fully opened.
- h. Push on the latch retainer hook end, collapsing the linkage, and confirm link assembly cam rolls out of latch freely. Reengage cam into latch, rotate linkage by thumb pressure to closed position and relock actuator arm with locking pin.

**NOTE**

To prevent damage to cable and to prevent improper locking of latch, reinsert cam and then rotate latch linkage to closed position before relocking actuator arm.

11. Periodically check if the four adjusting collar setscrews are tight.
12. Repair each individual component as described in WP 0013 00 through WP 0019 00.

**REPLACE**

1. Replace damaged or missing EFTC parts only as authorized by the RPSTL, WP 0068 00 – WP 0073 00.
2. Replace an unserviceable EFTC with a serviceable item from stock.

**END OF WORK PACKAGE**



---

**UNIT MAINTENANCE**  
**ANCILLARY EQUIPMENT FOR LOW VELOCITY AIR DROP SYSTEMS (LVADS)**  
**EXTRACTION FORCE TRANSFER COUPLING ADAPTER LINK ASSEMBLY**

---

**THIS TASK COVERS:**

- Inspect
  - Replace
- 

**Tools**

Wrench, Open-End 1 <sup>7</sup>/<sub>16</sub> and 1 <sup>5</sup>/<sub>8</sub>-IN. (Item 56, WP 0064 00)

**Materials/Parts**

Coupling, Extraction Force Transfer Adapter, Link Assembly (Item 1, WP 0068 00)

**Personnel Required**

92R (10) Parachute Rigger

**Equipment Condition**

Removed from the Extraction Force Transfer Coupling Adapter Link Assembly

**References**

WP 0005 00; WP 0068 00

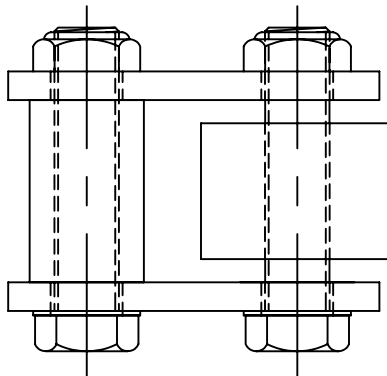
---

**INSPECT**

Inspect the link assembly adapter in accordance with WP 0005 00, using the procedures in Table 1 and the following procedures below:

**REPLACE**

1. Replace damaged or missing adapter link assembly parts only as authorized by WP 0068 00.
2. Replace an unserviceable adapter link assembly with a serviceable item from stock.



**END OF WORK PACKAGE**



---

**UNIT MAINTENANCE**  
**ANCILLARY EQUIPMENT FOR LOW VELOCITY AIR DROP SYSTEMS (LVADS)**  
**EXTRACTION FORCE TRANSFER COUPLING 3-POINT ADAPTER LINK ASSEMBLY**

---

**THIS TASK COVERS:**

- Inspect
  - Replace
- 

**Tools**

Wrench, Open-End, 1  $\frac{7}{16}$  and 1  $\frac{5}{8}$ -IN. (Item 56, WP 0064 00)

**Materials/Parts**

Coupling, Extraction Force Transfer Link Assembly, Coupling (Item 1, WP 0069 00)

**Personnel Required**

92R (10) Parachute Rigger

**Equipment Condition**

Removed from the Extraction Force Transfer Assembly

**References**

WP 0005 00; WP 0069 00

---

**INSPECT**

Inspect the link assembly, coupling in accordance with WP 0005 00, using the procedures in Table 1.

---

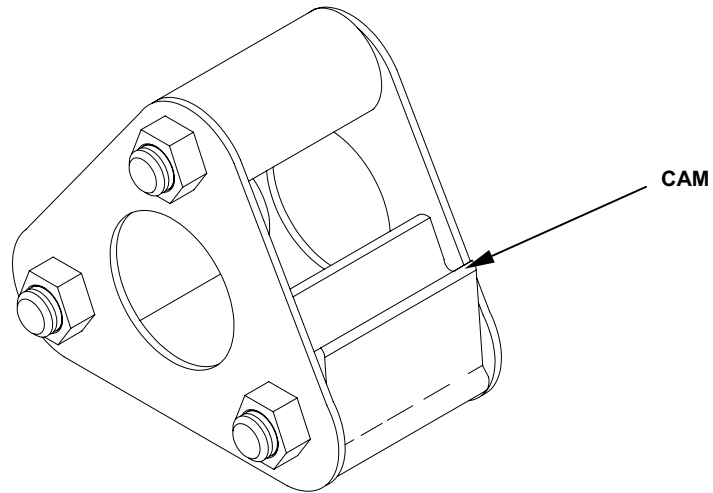
**WARNING**

---

Do not over tighten the self-locking nuts of the three-point coupling link assembly so that the cam will not rotate freely. This may result in a delay or failure of the force transfer and deployment of the recovery parachutes resulting in loss of equipment.

1. The following procedures shall be used to tighten all three self-locking nuts on the three point coupling link assembly:
  - a. Using a 1  $\frac{7}{16}$  and 1  $\frac{5}{8}$ -inch open-end wrench, tighten all three (3) self-locking nuts whereby the bottom of the nut must make contact with the side plate and then back off one-half turn so the cam and spools rotate freely.
  - b. Before engaging the three point coupling link, assembly into the latch assembly, check to see that the cam and spools between the side plates have sufficient slack and are always free to rotate as intended.
  - c. Check the proper engagement of the cam with the open latch assembly. The cam must fit without interference and seat properly into the latch assembly when the latch is manually relocked and the dot and arrows are aligned.

- d. If different cams are tried and none will engage and seat properly in the latch, the latch shall be tagged "defective latch" and set aside.

**REPLACE**

1. Replace damaged or missing link assembly parts only as authorized by the RPSTL, WP 0069 00.
2. Replace an unserviceable link assembly with a serviceable item from stock.

**END OF WORK PACKAGE**

---

**UNIT MAINTENANCE**  
**ANCILLARY EQUIPMENT FOR LOW VELOCITY AIR DROP SYSTEMS (LVADS)**  
**EXTRACTION FORCE TRANSFER COUPLING CONNECTOR LATCH ASSEMBLY**

---

**THIS TASK COVERS:**

- Inspect
  - Replace
- 

**Tools**

Screwdriver, Cross-Tip, No.1 (Item 27, WP 0064 00)  
Wrench, Open-End, 1 and 1 <sup>1</sup>/<sub>8</sub>.IN. (Item 57, WP 0064 00)

**Materials/Parts**

Coupling, Extraction Force Transfer Latch Connector Assembly,  
Coupling (Item 1, WP 0071 00)

**Personnel Required**

92R (10) Parachute Rigger

**Equipment Condition**

Removed from the Extraction Force  
Transfer Assembly

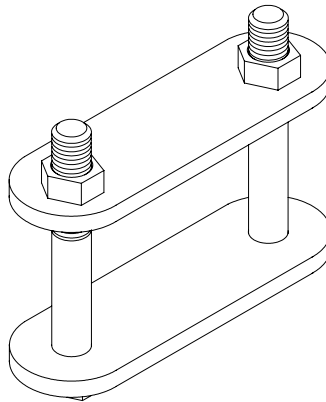
**References**

WP 0005 00; WP 0071 00

---

**INSPECT**

Inspect the latch assembly connector in accordance with WP 0005 00, using the procedures in Table 1 and the following procedures below:

**REPLACE****NOTE**

An unserviceable latch assembly coupling will not be repaired. Replace damaged or missing latch assembly only as authorized by WP 0071 00.

1. Replace damaged or missing latch assembly connector parts only as authorized by WP 0071 00.
2. Replace an unserviceable latch assembly connector with a serviceable item from stock.

**END OF WORK PACKAGE**





---

**UNIT MAINTENANCE**  
**ANCILLARY EQUIPMENT FOR LOW VELOCITY AIR DROP SYSTEMS (LVADS)**  
**EXTRACTION FORCE TRANSFER COUPLING LATCH ASSEMBLY COUPLING**

---

**THIS TASK COVERS:**

- Inspect
  - Service
  - Replace
- 

**Tools**

Brush, Wire, Stainless Steel (Item 4, WP 0064 00)  
 Hex Key, Set (Item 14, WP 0064 00)  
 Impact Socket Set, Manual (Item 15, WP 0064 00)  
 Mallet, Rawhide (Item 21, WP 0064 00)  
 Pliers, Slip Joint, Straight Nose (Item 23, WP 0064 00)  
 Punch, Center, Hardened (Item 26, WP 0064 00)  
 Screwdriver, Phillips, No. 3 (Item 29, WP 0064 00)  
 Wrench, Adjustable, 10-IN. (Item 49, WP 0064 00)  
 Wrench, Open End,  $\frac{7}{16}$ -IN. (Item 50, WP 0064 00)

**Personnel Required**

92R (10) Parachute Rigger

**Equipment Condition**

Removed from the Extraction Force Transfer Assembly.

**References**

WP 0005 00; WP 0018 00;  
 WP 0070 00

**Materials/Parts**

Coupling, EFTC Latch Assembly (Item 1, WP 0070 00)  
 Locktite, 222 (Item 18, WP 0125 00)  
 Lubricant, Solid Film (Item 20, WP 0125 00)  
 Paint, Yellow Enamel (Item 23, WP 0125 00)

---

**INSPECT**

Inspect the latch assembly in accordance with WP 0005 00, using the procedures in Table 1.

**SERVICE/REPAIR**

1. If possible, clean latch assembly using compressed air. When Latch does not function properly due accumulation of dirt, foreign material or rust on the internal parts, latch may be disassembled and cleaned as follows:

NOTE

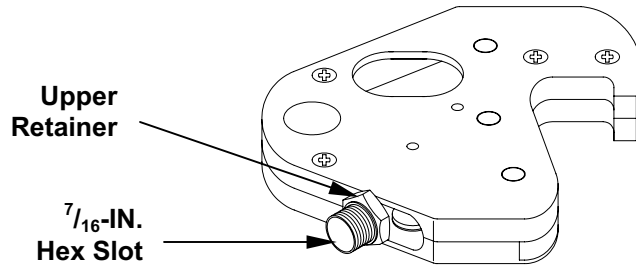
At any time during maintenance of the latch assembly, it is permissible to reapply the yellow enamel paint used to show the "dot and arrow".

- a. If the cable assembly is attached to the latch, remove the cable assembly before disassembling the latch IAW WP 0018 00.

NOTE

Parts manufactured after 2001 require the use of a  $\frac{7}{16}$ -inch hex key in the upper retainer to prevent it from turning under the action of the adjustable wrench.

- b. Place the latch on a flat clean working area and using a 10-inch adjustable wrench; loosen the self-locking nut on the upper retainer by turning the nut one to two turns counterclockwise.



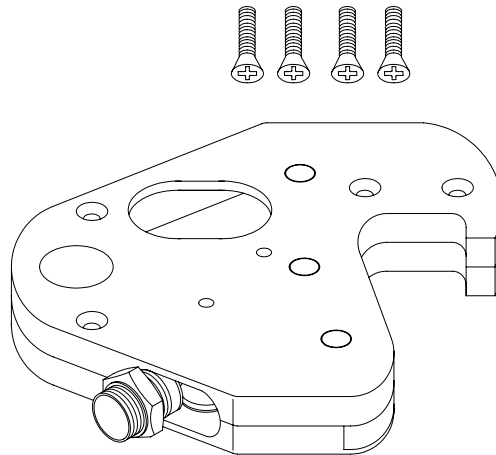
**CAUTION**

If an impact driver is used, proper eye protection should be used for protection against any metal chips that may be dislodged by the impact wrench.

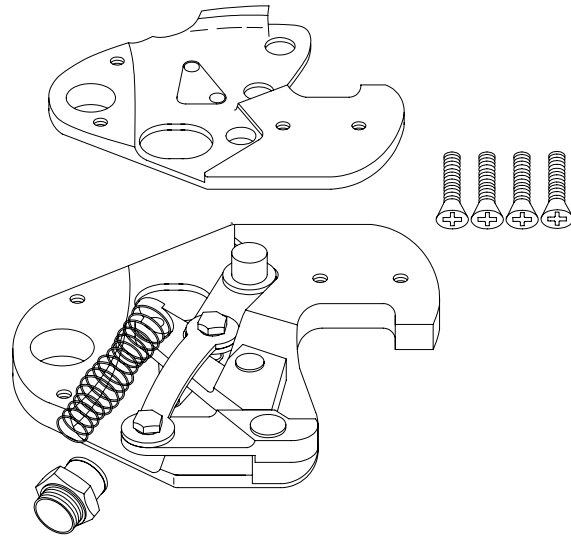
**NOTE**

If applicable, an impact driver set with  $\frac{5}{16}$ -inch hex bit holder and number two (2) Phillips head bit is a suitable substitution for a #3 Phillips head screwdriver.

- c. Using a #3 Phillips head screwdriver, remove the four crossed recessed machine screws holding the side plates together. If the machine screws are difficult to remove, an impact wrench may be used.



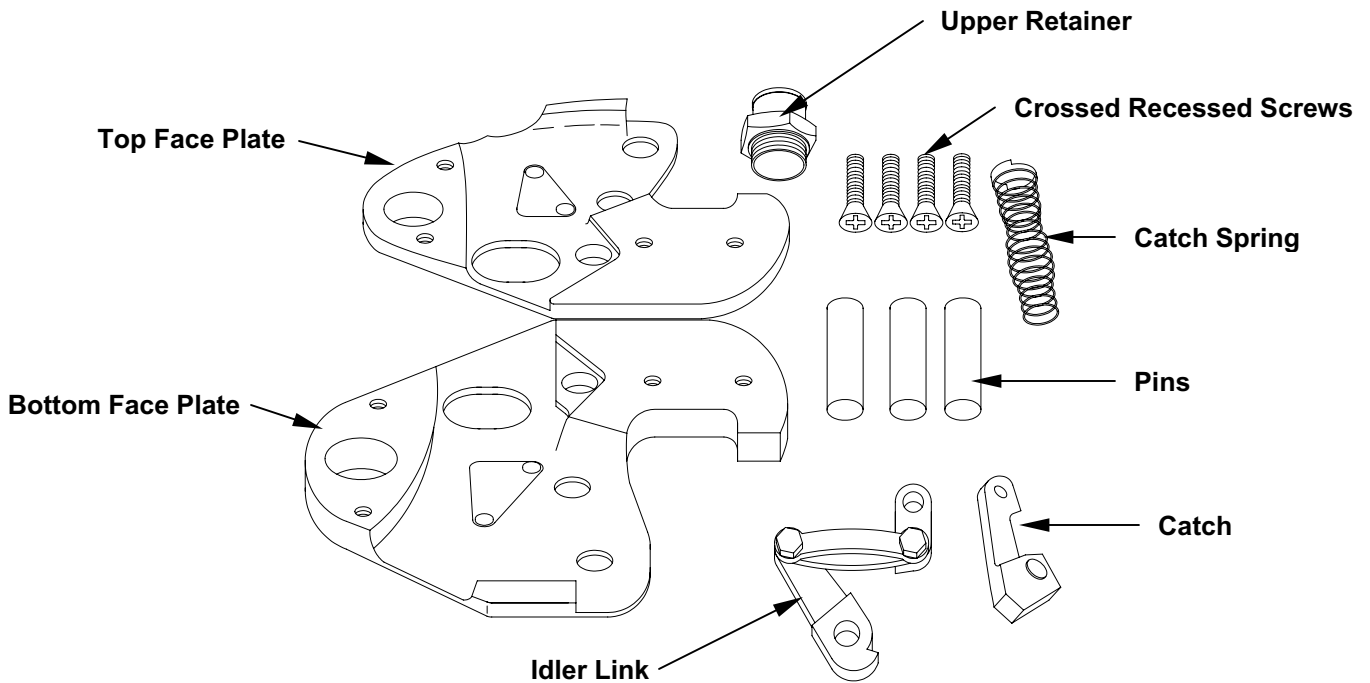
- d. Carefully remove the side plate. If the plates are difficult to separate, the ends of the plates may be tapped using a rawhide mallet.



**CAUTION**

Injury to personnel may occur when removing the side plate. To avoid injury, cover the catch spring with a free hand to prevent the spring from ejecting from the side plate towards the operators face.

- e. Carefully remove the catch spring, pins, and all the internal parts of the latch.

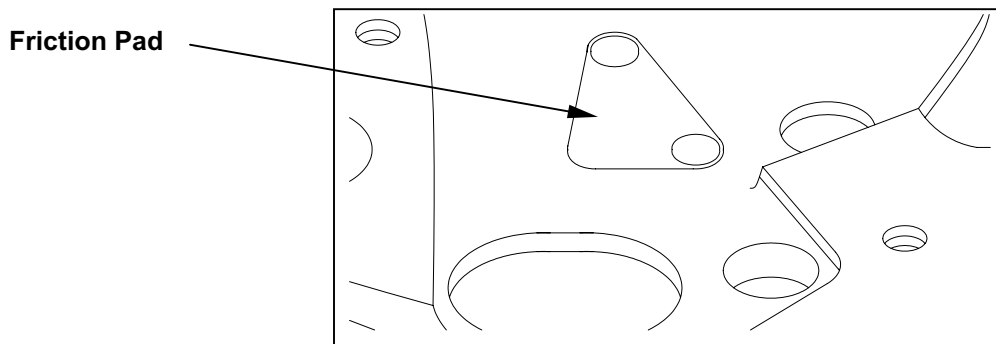


- f. Examine the internal parts for a buildup of dirt and corrosion.
- g. Compressed air may be used to remove any dirt and debris from the parts and the internal bearing surfaces. For rust and corrosion found on parts and the internal bearing surfaces, a stainless steel wire brush or emery cloth may be used.

**CAUTION**

The idler link rides on two friction pads riveted to the inside of each side plate. Small chips on the friction plate near rivet area are acceptable damage. Any side plates identified as having any breaks, cracks, or excessively worn friction pads in and around the center of the friction pad (the location the idler link rides against) will be removed from service.

- h. Inspect friction pads on each side plate for damage, cracks or excessive wear.

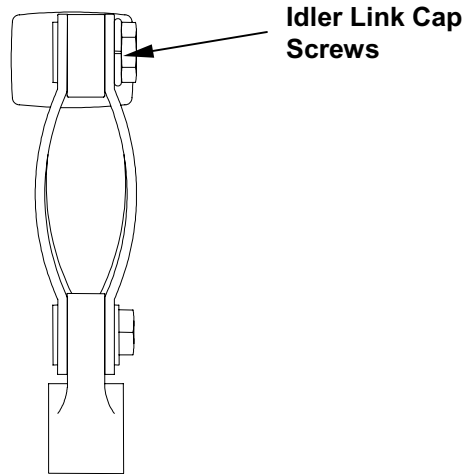


**NOTE**

If the cap screws in the idler link are not facing in the same direction, remove the cap screws and reassemble so they are both facing UP.

- i. If the cap screws in the idler link are loose or the parts do not move freely, use a  $\frac{7}{16}$ -inch open/box end wrench and slip joint pliers, remove the idler link cap screws, clean components and apply solid film lubricant to the bare metal parts.
- j. Reassemble idler link applying a thin coat of Locktite No. 222 to the threads of the cap screws.

- k. Tighten cap screws making sure the parts move freely without binding.



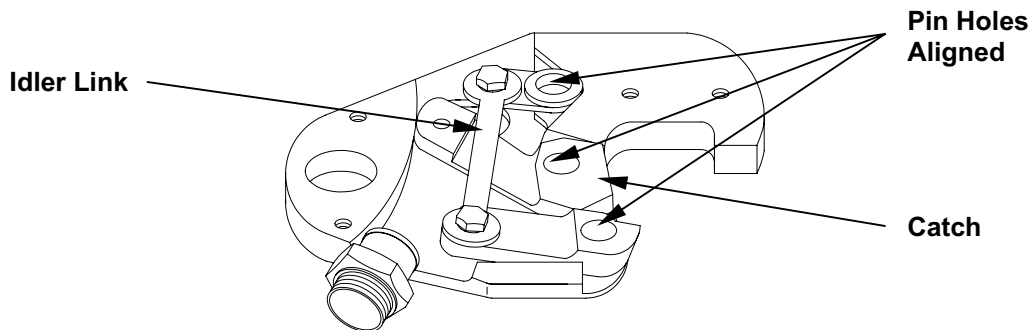
- l. Any surfaces of the latch that have bare metal exposed due to the cleaning procedures above must be recoated with a preservative. Use spray solid film lubricant, type II, let air dry one-hour.

**ASSEMBLE**

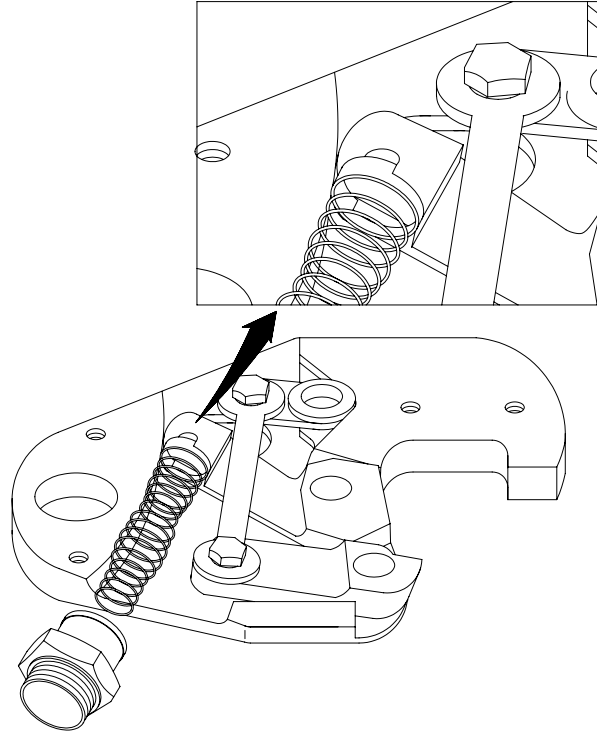
**NOTE**

On latches manufactured prior to 2001; the upper retainer has a semicircular shape that must be oriented to mate with the corresponding semicircular shape in the side plate, otherwise it will not be possible to properly assemble the side plates.

1. Position idler link in bottom latch plate with cap screws facing up and pin holes aligned.
2. Position catch between idler link arms aligning pinhole.



3. Replace pins in catch and idler link insuring they are fully seated.
4. Install catch spring insuring catch spring is properly seated over the catch, in the slot in the lower retainer, and the upper part of the spring is properly mated with the upper retainer.

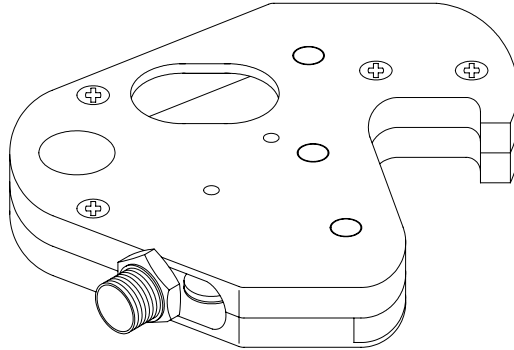


**NOTE**

The side plate is properly seated over the internal parts and pins if the side plates seat flush with each other. If the side plates do not mate flush with each other, make sure the catch spring and upper retainer is properly seated in the side plates.

5. While holding the catch spring in place, push in upper retainer and position the topside plate carefully over the internal parts and pins.
6. Apply a thin coat of Loctite No. 222 to the threads of the four crossed recessed machine screws.
7. Reinsert the four cross-recessed machine screws in the side plates and hand tighten.
8. Using a #3 Phillips screwdriver, tighten the four cross-recessed machine screws in the side plates as tight as possible with the hand.

9. Using a 10-inch adjustable wrench, retighten the locking nut on the upper retainer; do not over tighten the nut.



**NOTE**

If the  $\frac{1}{2}$ -inch diameter pins in the latch side plates, that secure the retainer and catch are separate pins or are an integral fixed pin one-piece construction, then staking is not necessary.

10. Determine if the pins are loose and can fall out through the side plates as follows:
- Using a flat surface, a  $\frac{3}{8}$ -inch diameter or less pin or bolt, tap gently with a hammer on each end of the  $\frac{1}{2}$ -inch diameter latch pins through the side plate holes.
  - If the pins are loose and can fall through the side plates, stake as follows:

**CAUTION**

Use of proper eye protection should be used for protection against any metal chips that may be dislodged when staking pins. Flying debris may cause injury to personnel.

- Place the assembled latch assembly on a solid level surface.
- Place the tip of the center punch approximately  $\frac{1}{16}$ -inch from the edge of the  $\frac{1}{2}$ -inch diameter hole in the side plate.
- Strike the punch with a hammer to cause a  $\frac{3}{32}$ -inch dimple and a slight flow of metal towards the inside edge of the hole which will then retain the latch pin as required.
- Repeat the staking at four places, 90 degrees apart from each other.
- Recheck for loose pins as described in step a. above.

**NOTE**

At any time during the operation of the EFTC latch, units are authorized to tighten the upper retaining nut flush with the latch assembly housing. Secure the latch in a clamp or vise prior to tightening the nut. **NO DO TIGHTEN WHILE ASSEMBLED AND RIGGED INSIDE THE AIRCRAFT.**

11. Manually operate the latch in accordance with FM 4-20.102 (FM 10-500-2). Apply thumb pressure on the catch to overcome the spring pressure and lift up the catch. The linkage can then be collapsed manually by pushing down on top of the retainer hook end. The latch shall relock manually with the dot and arrow aligned.
12. Check the latch and link assemblies for proper locking and seating IAW FM 4-20.102 (FM 10-500-2). If the dot and arrow are not aligned within  $\frac{1}{16}$ -inch, check to make sure that the lock link is fully seated into the catch slot, so that the catch is completely bottomed over the lock link.
13. If the latch is properly seated, but the dot and arrow remain misaligned by more than  $\frac{1}{16}$ -inch the visual locking indicators have been improperly set by the manufacturer. The latch must now be identified for continued use and further inspections.
14. A  $\frac{1}{2}$ -inch capital letter (I) must be stenciled on each side plate using yellow enamel paint. This will show that the unit is still usable for airdrop operations.
15. After the cable assembly installation during the EFTC pre-check and the pre-drop JAI, further positive lock must be checked on the latch assemblies to assure proper locking. These procedures are as follows:
  - a. Connect the cable to the latch and lock the actuator. If positive lock is felt more than  $\frac{1}{16}$ -inch from the position of alignment between the visual dot and arrow when thumb pressure is exerted on the latch, check the actuator as follows:
    - (1) Disconnect the cable from the actuator end and rotate the arm of the actuator to the locking position and insert locking pin to hold the arm.
    - (2) Check the locking position of the actuating link at the cable hole connecting point, measuring the distance between the center of this hole to the outside end of the actuator housing from which the cable extends.
    - (3) If the measured distance does not exceed two and one half inches, the cable was adjusted incorrectly. Do not use the cable.
    - (4) If the measured distance exceeds two and one half inches, the actuator arm/shaft was improperly fabricated to provide adequate cable locking stroke. Do not use the actuator.
  - b. If the dot and arrow are not aligned within  $\frac{1}{16}$ -inch when the latch is locked, visually check through the 1-inch slotted hole in the latch side plates that the catch is completely seated over the lock link.
  - c. Check to see that the arrow points to the surface of the lock link that is engaged with the catch.
  - d. Push up on the catch with sufficient force to overcome the catch spring resisting force.
  - e. A positive lock must be indicated by a solid resistance provided by the cable assembly connection within  $\frac{1}{16}$ -inch of catch movement.



- f. The procedures and inspections stated above will assure that the latch assemblies with misaligned locking indicators are properly locked.
- g. These procedures and inspections should be conducted before each airdrop use of the latch assembly.

**REPLACE****NOTE**

If after assembly the latch does not function properly, no further repair is authorized. Replace latch assembly only as authorized by WP 0070 00.

1. Replace damaged latch assembly, coupling parts only as authorized by WP 0070 00.
2. Replace an unserviceable latch assembly, coupling with serviceable item from stock.

**END OF WORK PACKAGE**



---

**UNIT MAINTENANCE**  
**ANCILLARY EQUIPMENT FOR LOW VELOCITY AIR DROP SYSTEMS (LVADS)**  
**EXTRACTION FORCE TRANSFER COUPLING CABLE ASSEMBLY**

---

**THIS TASK COVERS:**

- Inspect
  - Replace
- 

**Tools**

None

**Personnel Required**

92R (10) Parachute Rigger

**Materials/Parts**Coupling, Extraction Force Transfer Cable Assembly,  
Coupling (WP 0072 00)**Equipment Condition**Removed from the Extraction Force  
Transfer Assembly.**References**FM 4-20.102(FM 10-500-2);  
T.O. 13C7-1-5

---

**INSPECT**

Inspect the coupling link assembly, in accordance with WP 0005 00, using the procedures in Table 1 as well as the following procedures:

All cable assemblies must be inspected prior to every airdrop as follows:

1. Extend the cable straight and apply a manual push/pull force on the ends of the inner cable.
2. Check for any friction or resistance to push/pull of the inner cable.
3. An approximate manual push/pull force detecting any friction, resistance or force exceeding 10-pounds under a spring scale applied to the ends of the cable will indicate a defective cable assembly.
4. Visually check both ends of the inner cable for any "birdcage" effect or damage.
5. Bird caging of the inner wire cable is defined as any visible unraveling or physical deformation of the inner wire cable strands.
6. Visually inspect both ends of all lengths of EFTC cable assemblies produced by all manufacturers for bird caging of the inner wire cable.
7. There is no authorized repair for the damaged cable assemblies found with bird caging.
8. Dispose of in accordance with local standard procedures for damaged airdrop equipment.
9. Cable assemblies that pass the manual push/pull test and do not show signs of bird caging should be connected to a good EFTC actuator and latch assembly to check for proper positive lock in the latch assembly.
10. Check for proper operation of the actuator assembly to completely open the catch in the latch assembly IAW FM 4-20.102 (FM 10-500-2)/T.O. 13C7-1-5.
11. If proper operation is not achieved, the cable assembly can be considered defective. There is no authorized repair for the defective cable.
12. During pre-airdrop rigging and functional inspections, unlock and rotate the actuator arm to check the operation of the latch assembly.

13. Do not re-cock the actuator arm until the latch linkage is reset manually to accept the engagement of the catch (dot and arrow align).

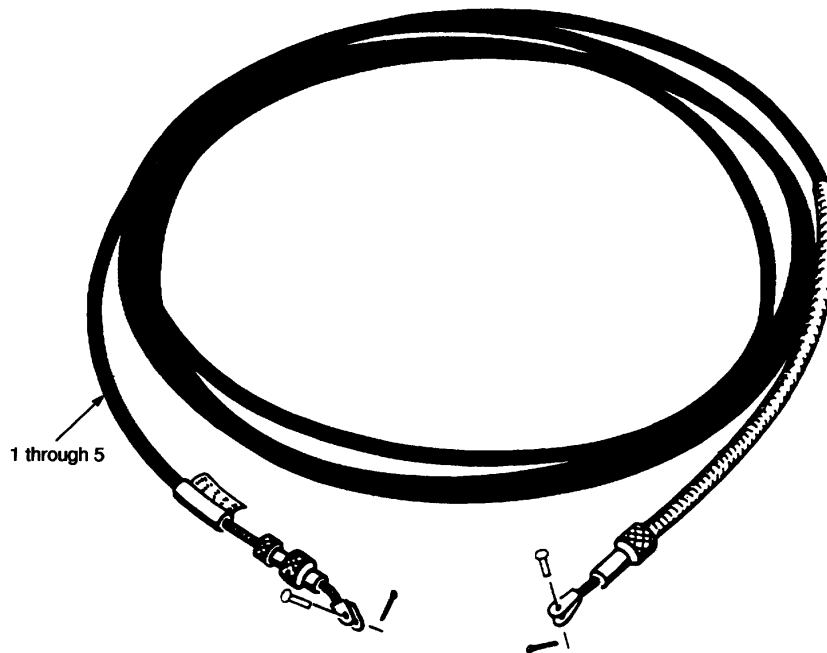
**WARNING**

When the cable assembly is installed to the actuator and latch assembly, avoid any unnecessary turning and twisting of the actuator or latch. Damage to the inner cable construction may occur. If these procedures and pre-cautions are not followed, damage may occur which could cause a possible malfunction.

14. If twisting and turning occurs during the pre-airdrop rigging, disconnect the cable assembly from the latch and actuator assembly and repeat the manual push/pull test as stated above.

**REPLACE**

1. Replace an unserviceable or missing straight-headed pin or ½-inch long cotter pin on either end of the cable with a serviceable item from stock.
2. Replace an unserviceable 12-, 16-, 20-, 24-, 28-foot long cable assembly with a serviceable item from stock.



**END OF WORK PACKAGE**

---

**UNIT MAINTENANCE**  
**ANCILLARY EQUIPMENT FOR LOW VELOCITY AIR DROP SYSTEMS (LVADS)**  
**EXTRACTION FORCE TRANSFER COUPLING ACTUATOR ASSEMBLY**

---

**THIS TASK COVERS:**

- Inspect
  - Replace
- 

**Tools**

Straight Edge, 2-IN. (Item 45, WP 0064 00)  
Wrench, Open-End, 1 <sup>7</sup>/<sub>16</sub>-IN. and 1 <sup>5</sup>/<sub>8</sub>-IN. (Item 56, WP 0064 00)

**Materials/Parts**

EFTC Actuator Assembly (Item 1, WP 0073 00)

**Personnel Required**

92R (10) Parachute Rigger

**Equipment Condition**

Removed from the Extraction Force Transfer Assembly.

**References**

WP 0073 00; WP 0005 00; WP 0017 00

---

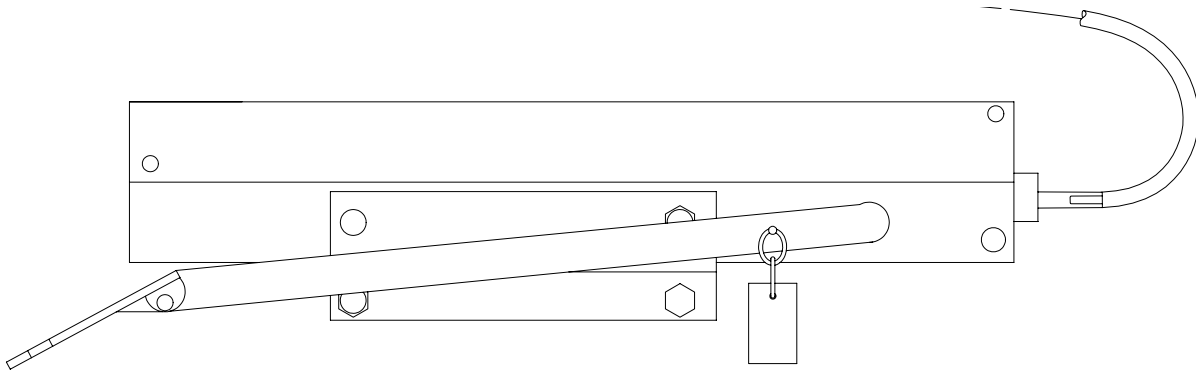
**INSPECT**

Inspect the actuator assembly in accordance with WP 0005 00, using the procedures in Table 1, as well as the following procedures:

1. All actuator assemblies must be checked prior to every airdrop.
2. Inspect the actuator spring guide rod as follows:
  - a. Rotate the actuator arm clockwise until the spring guide rod is fully extended and lock the actuator arm into position with the appropriate quick release pin.
  - b. Place a 2-inch straight edge (or equivalent) on the fork end of the spring guide rod.
  - c. If spring guide rod shows any bend or curvature against straight edge, remove EFTC from service.
3. Check for free movement of actuator arm latching pin as follows:
  - a. Pull latch ring on side of actuator to determine if latch pin moves freely under force of latch spring.
  - b. Slowly rotate actuator arm counterclockwise to ensure arm pushes in latch pin and latch pin snaps back into position to secure the arm from rotating clockwise.
  - c. If latch pin sticks in one position, check for binding, bends, dirt, or debris on the latch pin assembly inside actuator. Remove dirt and foreign matter but if pin is bent, remove EFTC from service.
4. Once the EFTC has been mounted to the platform, check the latch assembly coupling IAW WP 0017 00.

**REPLACE**

1. Replace damaged or missing actuator assembly parts only as authorized by WP 0073 00.
2. Replace an unserviceable actuator assembly with a serviceable item from stock.

**END OF WORK PACKAGE**

---

**UNIT MAINTENANCE**  
**ANCILLARY EQUIPMENT FOR LOW VELOCITY AIR DROP SYSTEMS (LVADS)**  
**M-1 CARGO PARACHUTE RELEASE**

---

**THIS TASK COVERS:**

- Inspect
  - Repair
  - Replace
- 

**Tools**

Brush, Scrub, Household (Item 2, WP 0064 00)  
 File, Bastard (Item 8/9, WP 0064 00)  
 Knife, Hot Metal (Item 18, WP 0064 00)  
 Knife, Pocket (Item 19, WP 0064 00)  
 Screwdriver, Cross-Tip, No.2 (Item 28, WP 0064 00)  
 Screwdriver, Flat-Tip,  $\frac{3}{16}$ -IN. (Item 30, WP 0064 00)  
 Sewing Machine, Zig-Zag (Item 39/40, WP 0064 00)  
 Shear, Trimmer (Item 41, WP 0064 00)  
 Wrench, Open-End, 1  $\frac{1}{4}$  and 1  $\frac{5}{16}$ -IN. (Item 52, WP 0064 00)  
 Wrench, Open-End, 1  $\frac{1}{2}$  and 1  $\frac{3}{4}$ -IN. (Item 53, WP 0064 00)  
 Wrench, Open-End,  $\frac{13}{16}$  and  $\frac{7}{8}$ -IN. (Item 58, WP 0064 00)  
 Wrench, Open-End,  $\frac{5}{8}$  and  $\frac{9}{16}$ -IN. (Item 60, WP 0064 00)

**Materials/Parts**

10-Ounce Weight (Item 38, WP 0125 00)  
 Marker, Felt-Tip, Black (Item 21, WP 0125 00)  
 Pen, Ballpoint (Item 24, WP 0125 00)  
 Rag, Wiping (Item 25, WP 0125 00)  
 Release, Cargo Parachute, M-1 (Item 1, WP 0074 00)  
 Thread, Nylon, Size FF (Item 33, WP 0125 00)  
 Webbing, Cotton, Type I,  $\frac{1}{4}$ -IN. Wide (Item 35, WP 0125 00)  
 Webbing, Nylon, Type VIII (Item 36, WP 0125 00)  
 Wire, 20 Gauge (Item 39, WP 0125 00)

---

**Personnel Required**

92R (10) Parachute Rigger

**Equipment Condition**

Removed from the parachute linkage.

**References**

WP 0005 00; WP 0007 00; WP 0008 00; WP 0023 00; WP 0074 00

**INSPECT**

1. Inspect the M-1 parachute release in accordance with WP 0005 00, using the procedures in Table 1.

**NOTE**

A delay release timer will be tested prior to every use. Testing of a timer will only be conducted with the timer installed and armed within an assembled serviceable parachute release.

2. Inspect Timing.
  - a. Cut a suitable length of type I,  $\frac{1}{4}$ -inch wide cotton webbing for use in fabricating an improvised sling.
  - b. Using a length of suitable wire as an aid, pass one end of the webbing length up between the release side plates, over and around the center of the timer, and back down between the side plates to a point below the release body.
  - c. Attach and suspend a 10-ounce weight to the sling webbing at a point below the release body. This adds resistance to the timer mechanism keys.

- d. Suspend the release in a vertical position and activate the timer mechanism by pulling the arming wire from the guide block located on the release face side plate.
- e. Check the time it takes for the release assembly to drop.
- f. When using a 15-second timer, the time should drop inside the release within a minimum of 12-seconds and a maximum of 16-seconds. If the timer fails to meet the requirements, it is considered defective and should be replaced with a serviceable timer and stem assembly from stock.

NOTE

If the time assembly fails to drop in the required time, remove the faceplate and check the four screws securing the arming wire guide block to the faceplate for burred heads. If the heads are burred, remove it by filing or replacing with new screws.

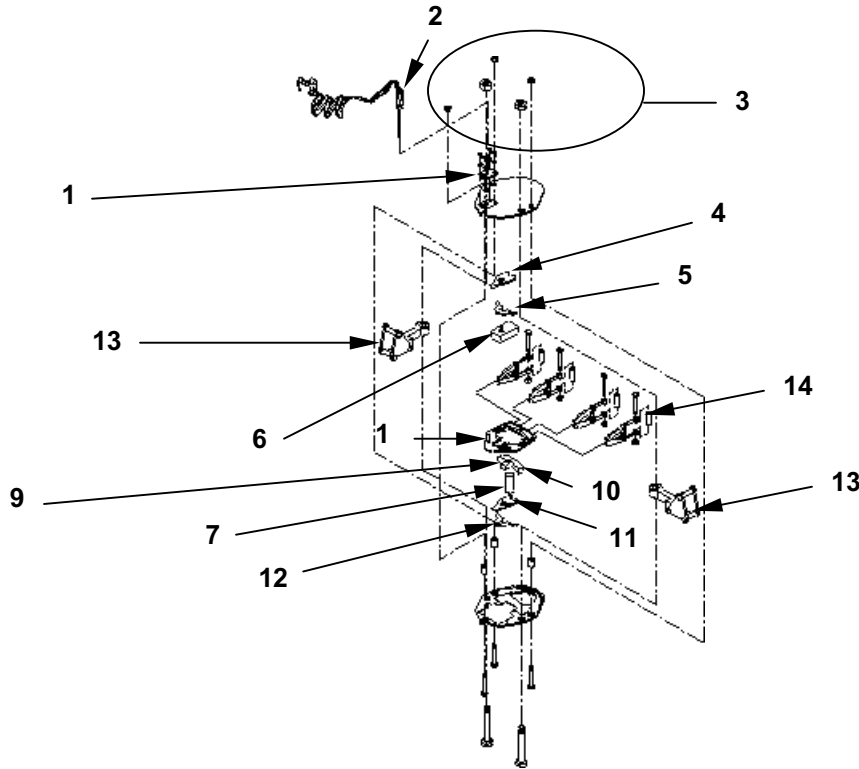
- g. Remove the fabricated sling and the 10-ounce weight from the release.

## REPAIR

1. Disassemble the release.
  - a. Place the release on a table or other suitable flat surface with the side plate containing the arming wire guide block **(1)** facing up.
  - b. If the arming wire **(2)** is installed, pull the wire clear of the guide block and allow the delay release timer to run down.
  - c. Remove the five nuts **(3)** securing the side plate to the release and lift the face side plate from the release.
  - d. Remove the exposed toggle **(4)**, toggle lockslide **(5)**, and the delay release timer **(6)** from the release timer.
  - e. Remove the toggle shaft **(7)** and the upper suspension link **(8)** with the retaining clamp **(9)** from the release.
  - f. Remove the retaining clamp **(9)** with the retaining clamp pin **(10)** from within the upper suspension link by sliding the clamp down and out through the opening in the link.
  - g. Remove the remaining toggle **(11)** and toggle lockslide **(12)** from the release backside plate.
  - h. Lift each of the two lower suspension links **(13)** from the points of mounting on the  $\frac{5}{8}$ -inch bolts.
  - i. Remove the three spacers, two  $\frac{5}{8}$ -inch bolts, and three  $\frac{3}{8}$ -inch bolts from the backside plate.
  - j. Disassemble each of the lower suspension links **(13)** by removing the three  $\frac{5}{8}$ -inch nuts, the three  $\frac{5}{8}$ -inch bolts, the load suspension spacers, and the two load suspension links.
  - k. As required, disassemble each parachute release connector **(14)** by removing  $\frac{9}{16}$ -inch nut, bolt, and sleeve spacer from the upper end of the connector.



- I. Inspect and repair the parachute connectors (14) and the timer delay assembly (6) as described in the REPAIR TIMER DELAY ASSEMBLY, TOGGLE AND KEYS paragraph and WP 0023 00.
2. Clean components.
  - a. Clean each component, except the arming wire, using procedures in WP 0008 00. Clean the arming wire only by wiping it with a soft, dry cloth.
  - b. If necessary, remove dirt and debris from inaccessible locations using a compressed air hose.



3. Repair timer delay assembly, toggle and keys.
  - a. Remove the four screws that hold the back cover of the delay assembly. Carefully remove cover, toggle, and keys from the housing.
  - b. Thoroughly brush foreign material away from the toggle and keys and from the surfaces from which the toggle keys were removed. If the parts are rusty, corroded, pitted, or signs of marks are present where the toggle has rubbed up against the channel in which the keys slide, replace the delay assembly, toggle or keys with a serviceable one from stock.

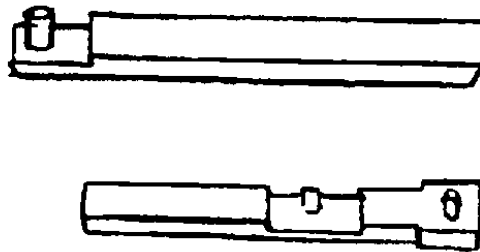
**CAUTION**

Do not use steel wool or a wire brush to clean, as these will damage the permanent dry film lubricant that was applied to the key-way surfaces when they were manufactured.

- c. Clean housing cover with brush.
- d. Insert the short key onto the timer actuator pin, into its slot with its pin facing outward.
- e. Insert the longest key into its slot, also with its pin facing outward.
- f. Adjust the two installed keys so that their pins are aligned with the pin in the housing and install the toggle over all three pins.
- g. Check to see that the short key is properly located onto the timer's spring-located actuator pin (6) and that the toggle is located onto all three pins in line.
- h. Replace housing cover over keys with countersunk holes facing outward and rounded corners along outer edge of timer housing. Check for alignment of holes and install four screws carefully. Do not over-tighten screws.
- i. Turn timer stem  $\frac{1}{4}$  turn to right and check if keys extend from each side of housing. Release stem and allow the timer to run down, making sure that the keys retract at the end when the timer runs down.

NOTE

The interlock pin must be down before the timer can be armed.



4. Reassemble release.

NOTE

The faceplate bolts for the M-1 Cargo Parachute Release are the correct type and length when they come with the complete assembly. However, many spare part bolts available are different when you requisition them. A spare part bolt of the same material with the correct length is identified by bolt, NSN 5306-00-207-8362, part number, AN6-25A. However, an additional bolt has been sold and may be used until exhausted. This bolt is NSN 5306-00-638-5821, Part Number AN6H-25A. This substitute bolt is the correct length and size, but it has a hole drilled in the head for specific aircraft applications. This bolt is acceptable for use in the assembly and application of the M-1 cargo parachute release.

- a. If required, reassemble each parachute release connector.
- b. Reassemble each of the lower suspension links by connecting the three  $\frac{5}{8}$ -inch nuts, the three  $\frac{5}{8}$ -inch bolts, the load suspension spacers, and the two load suspension links.
- c. Place the three spacers, two  $\frac{5}{8}$ -inch bolts, and three  $\frac{3}{8}$ -inch bolts within the backside plate.
- d. Place each of the two lower suspension links on the points of mounting on the  $\frac{5}{8}$ -inch bolts.
- e. Place the first toggle and toggle lockslide into the appropriate depression in the release back side plate.

NOTE

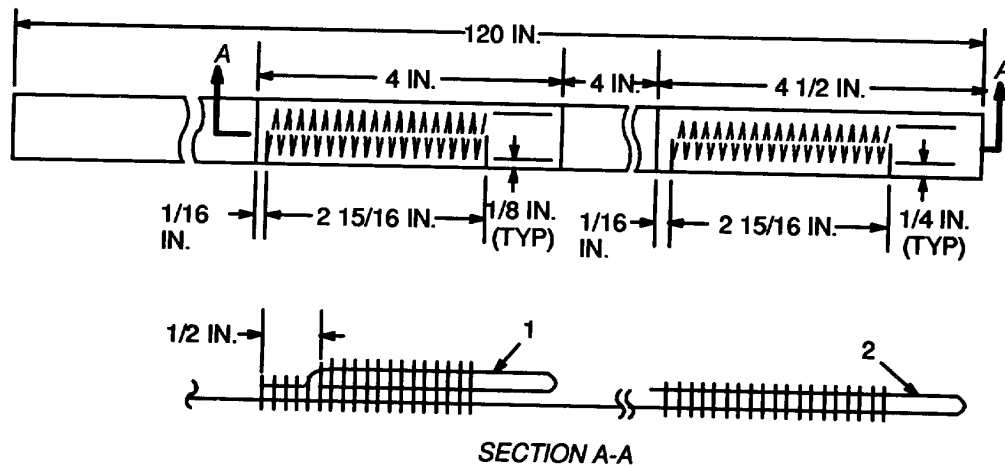
A tolerance problem was identified with the retaining clamp assembly included in the M-1 cargo parachute release modification kit. The retaining clamp assembly exceeds the maximum dimensional tolerances and will not fit in the upper suspension link. The modification kits can be identified by NSN 1670-01-332-7680, Part Number 11-1-3908, Contract Number DAA01-97-P-0175, Cage Code 71304, Capewell Components Company. There were 226 modification kits issued to the field. The retaining clamp is stamped with a cage code of 71304. If found dispose of IAW local procedures.

- f. Replace the retaining clamp with the retaining clamp pin within the upper suspension link by sliding the clamp up and in through the opening in the link.
- g. Replace the toggle shaft and the upper suspension link with the retaining clamp within the release.
- h. Replace the second toggle, toggle lockslide, and the delay release timer within the release timer.
- i. Place the face side plate onto the release. Install the five nuts securing the side plate to the release.
- j. If the arming wire needs to be installed, thread the wire through the appropriate hole. Ensure that the release works properly, IAW the INSPECT TIMING paragraph under the INSPECT procedures.

## REPLACE

1. Replace an unserviceable M-1 airdrop cargo parachute release with a serviceable item from stock.
2. Except for the arming wire lanyard, any other component of the M-1 airdrop cargo parachute release that is missing or unserviceable will be replaced only as authorized in WP 0074 00.
3. Replace an unserviceable arming wire lanyard by fabrication as follows:
  - a. Cut the unserviceable arming wire lanyard from the arming wire.
  - b. Cut a 124  $\frac{1}{2}$ -inch length and a 7  $\frac{1}{2}$ -inch length of  $\frac{1}{2}$ -inch wide tubular nylon webbing and sear the ends of both webbing lengths. Avoid forming a sharp edge or lumped effect on the melted end.
  - c. Mark the 124  $\frac{1}{2}$ -inch length of webbing at points 3, 4  $\frac{1}{2}$ , and 13-inches from one end.

- d. Form the arming wire attaching loop (1) on the webbing length by folding the marked end of the webbing back at the 4 1/2-inch mark.
- e. Using ZZ sewing machine stitching 7 to 11 stitches per inch (3 to 4 stitches per cm), secure the webbing foldback. Beginning at the 3-inch mark, stitch a 2 15/16 -inch long row of 1/4-inch wide double throw zigzag stitching toward the foldback seared end according to the details in the figure below. End the stitch row at a point 1/6-inch back from the foldback seared end.
- f. Mark the 7 1/2-inch webbing length at points 3 and 4-inches from one end.
- g. Form the safety tie loop (2) by doubling the webbing length at the 4-inch mark, allowing one end to overlap the opposite end by 1/2-inch.
- h. Position the folded 7 1/2-inch webbing length on the 124 1/2-inch webbing length with the 3-inch long end of the folded webbing facedown and the folded end aligned with the 13-inch mark made in step c. above.
- i. Beginning at the 3-inch mark, secure the folded webbing length by stitching as outlined in step e. above.
- j. Insert the arming wire attaching loop on one end of the lanyard through the loop located at the top of the arming wire.
- k. Pass the opposite end of the lanyard through the arming wire attaching loop and draw the lanyard length taut to form a tight attaching loop at the top of the arming wire.



END OF WORK PACKAGE

---

**UNIT MAINTENANCE**  
**ANCILLARY EQUIPMENT FOR LOW VELOCITY AIR DROP SYSTEMS (LVADS)**  
**M-2 CARGO PARACHUTE RELEASE**

---

**THIS TASK COVERS:**

- Inspect
  - Repair
  - Replace
- 

**Tools**

Brush, Scrub, Household (Item 2, WP 0064 00)  
Wrench, Open-End,  $\frac{3}{4}$  and  $\frac{13}{16}$ -IN. (Item 51, WP 0064 00)  
Wrench, Open-End,  $\frac{13}{16}$  and  $\frac{7}{8}$ -IN. (Item 58, WP 0064 00)  
Wrench, Open-End,  $\frac{15}{16}$  and 1-IN. (Item 59, WP 0064 00)

**Materials/Parts**

Pen, Ballpoint (Item 24, WP 0125 00)  
Rag Wiping (Item 25, WP 0125 00)  
Webbing, Cotton, Type I,  $\frac{1}{4}$ -IN. (Item 35, WP 0125 00)

**Personnel Required**

92R (10) Parachute Rigger

**Equipment Condition**

Removed from the parachute linkage.

**References**

WP 0005 00; WP 0007 00; WP 0008 00; WP 0077 00

---

**INSPECT**

1. Inspect the M-2 parachute release in accordance with WP 0005 00, using the procedures in Table 1.
2. Inspect timing as follows:

NOTE

A delay release timer will be tested prior to every use. Testing of a timer will only be conducted with the timer installed and armed within an assembled serviceable parachute release.

- a. Cut a suitable length of type I,  $\frac{1}{4}$ -inch wide cotton webbing for use in fabricating an improvised sling.
- b. Using a length of suitable wire as an aid, pass one end of the webbing length up between the M-2 release side plates, over and around the center of the timer, and back down between the side plates to a point below the release body.
- c. Attach and suspend a 10-ounce weight to the sling webbing at a point below the release body. This adds resistance to the timer mechanism keys.
- d. Suspend the release in a vertical position and activate the timer mechanism by pulling the arming wire from the guide block located on the release face side plate.
- e. Check the time it takes for the release assembly to drop.
- f. When using a 15-second timer, the timer should drop inside the release within a minimum of 12-seconds and a maximum of 16-seconds. If the timer fails to meet the requirements, it is considered defective and should be replaced with a serviceable timer and stem assembly from stock.

**NOTE**

If the timer assembly fails to drop in the required time, remove the faceplate and check the four screws securing the arming wire guide block to the faceplate for burred heads. If the heads are burred, remove it by filing or replacing with new screws.

- g. Remove the fabricated sling and the 10-ounce weight from the release.

**REPAIR**

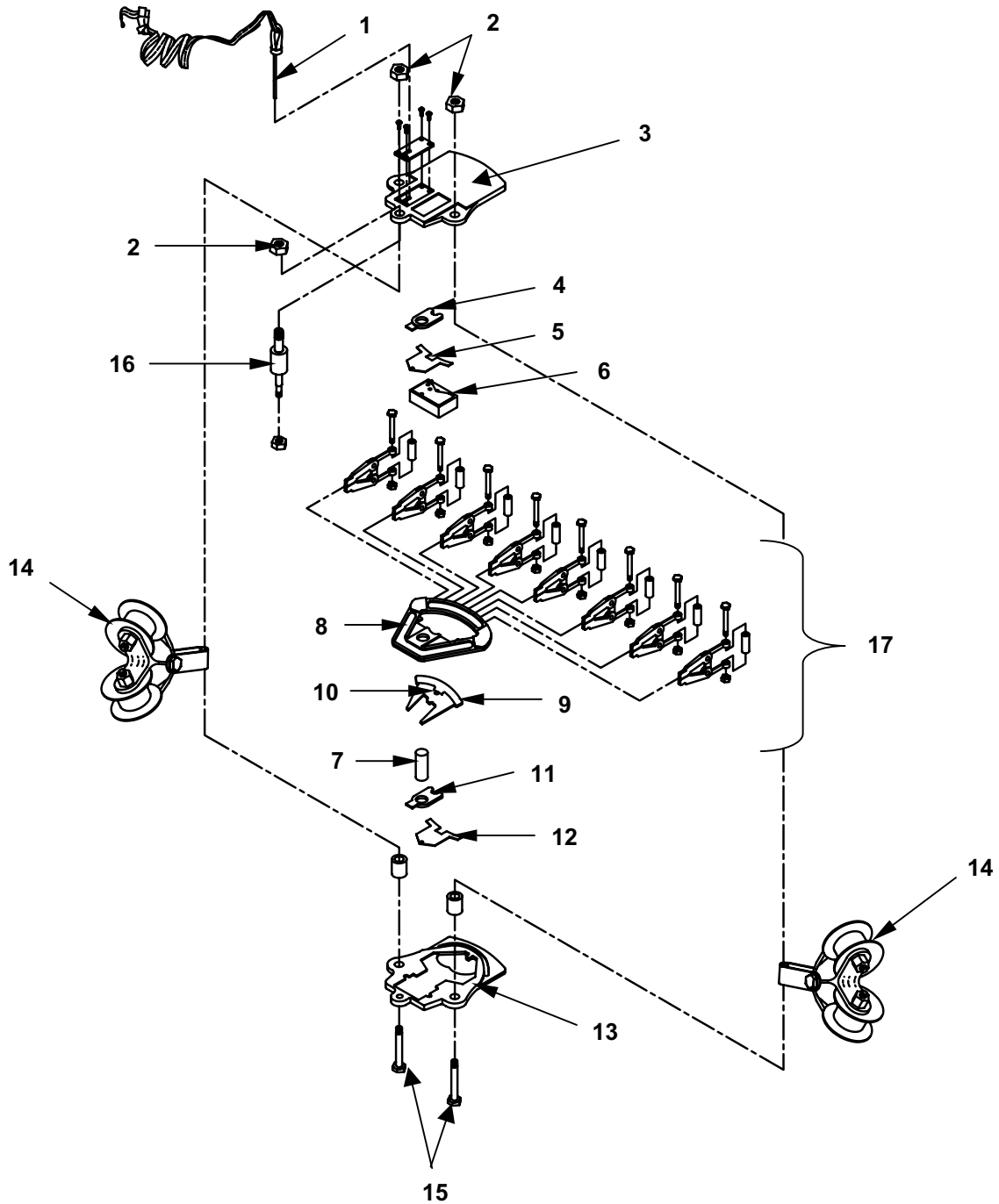
1. Disassemble the release as follows:
  - a. Place the release on a table or other suitable flat surface with the front plate containing the arming wire guide block facing up.
  - b. If the arming wire (1) is installed, pull the wire clear of the guide block and allow the delay release timer to run down.
  - c. Remove the three nuts (2) securing the faceplate (3) to the release and lift the faceplate from the release.
  - d. Remove the exposed toggle (4), toggle lockslide (5), and the timer mechanism (6) from the release body.
  - e. Remove the toggle shaft (7) and the upper suspension link (8) from the release.
  - f. Remove the retaining clamp (9) with the retaining clamp pin (10) from within the upper suspension link (8) by sliding the clamp down and out through the opening in the link.
  - g. Remove the remaining toggle (11) and toggle lockslide (12) from the inside of the release back plate (13).
  - h. Lift each of the two lower suspension links (14) from the two clevis bolts (15) on the release back plate.
  - i. Remove the two clevis bolts (15) and the lower stud (16) from the back plate by removing the applicable nuts on the outside of the back plate.
  - j. Further disassemble each of the lower suspension links (14) by removing the two  $\frac{5}{8}$ -inch nuts, the two suspension link sleeves, the sling guides, the  $\frac{9}{16}$ -inch clevis bolt nut, the clevis bolt, and the suspension link clevis.
  - k. As required, disassemble each parachute release connector (17) by removing the  $\frac{9}{16}$ -inch nut, bolt, and sleeve spacer from the upper end of the connector.

**CAUTION**

Do not apply lubricant of any type to the delay release timer.

2. Clean components as follows:

- a. Clean each component, except the arming wire, using procedures in WP 0008 00. Clean the arming wire only by wiping it with a soft, dry cloth.
- b. If necessary, remove dirt and debris from inaccessible locations using a compressed air hose.



3. Repair toggle and keys as follows:

- a. Remove the four screws that hold the back cover of the delay assembly. Carefully remove cover, toggle, and keys from the housing.
- b. Thoroughly brush foreign material away from the toggle and keys and from the surfaces from which the toggle keys were removed. If the parts are rusty, corroded, pitted, or marks are present where the toggle has rubbed up against the channel in which the keys slide, replace the delay assembly, toggle or keys with a serviceable one from stock.

**CAUTION**

Do not use steel wool or a wire brush to clean, as these will damage the permanent dry film lubricant that was applied to the key-way surfaces when they were manufactured.

- c. Clean housing cover with brush.
- d. Insert the short key onto the timer actuator pin, into its slot with its pin facing outward.
- e. Insert the longest key into its slot, also with its pin facing outward.
- f. Adjust the two installed keys so that their pins are aligned with the pin in the housing and install the toggle over all three pins.
- g. Check to see that the short key is properly located onto the timer's spring-loaded actuator pin **(6)** and that the toggle is located onto all three pins in line.

**NOTE**

The interlock pin must be down before the timer can be armed.

- h. Replace housing cover over keys with countersunk holes facing outward and rounded corners along outer edge of timer housing. Check for alignment of holes and install four screws carefully. Do not over-tighten screws.
- i. Turn timer stem  $\frac{1}{4}$  turn to right and check if keys extend from each side of housing. Release stem and allow the timer to run down, making sure that the keys retract at the end when the timer runs down.

**NOTE**

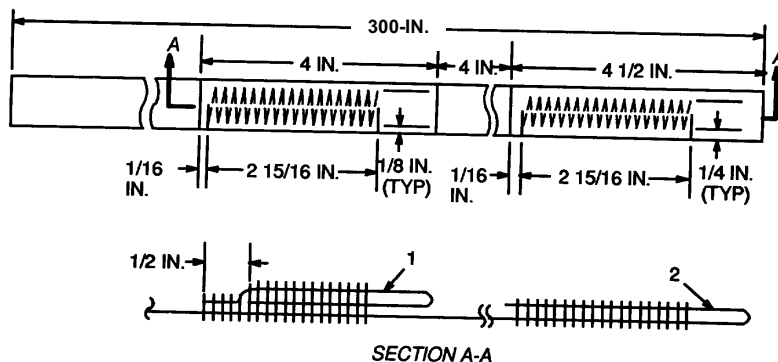
The interlock pin must be down before the timer can be armed.

**REPLACE**

1. Replace an unserviceable M-2 airdrop cargo parachute release with a serviceable item from stock.



2. Except for the arming wire lanyard, any other component of the M-2 airdrop cargo parachute release that is missing or unserviceable will be replaced only as authorized in WP 0077 00.
3. Replace an unserviceable arming wire lanyard by fabrication as follows:
  - a. Cut the unserviceable arming wire lanyard from the arming wire.
  - b. Cut a 304 ½-inch length and a 7 ½-inch length of ½-inch wide tubular nylon webbing and sear the ends of both webbing lengths. Avoid forming a sharp edge or lumped effect on the melted end.
  - c. Mark the 304 ½-inch length of webbing at points 3, 4 ½, and 13-inches from one end.
  - d. Form the arming wire attaching loop (1) on the webbing length by folding the marked end of the webbing back at the 4 ½-inch mark.
  - e. Using ZZ sewing machine stitching 7 to 11 stitches per inch, secure the webbing foldback. Beginning at the 3-inch mark, stitch a 2 15/16-inch long row of ¼-inch wide double throw zigzag stitching toward the foldback seared end according to the details in the figure below. End the stitch row at a point 1/6-inch back from the foldback seared end.
  - f. Mark the 7 ½-inch webbing length at points 3 and 4-inches from one end.
  - g. Form the safety tie loop (2) by doubling the webbing length at the 4-inch mark, allowing one end to overlap the opposite end by ½-inch.
  - h. Position the folded 7 ½-inch webbing length on the 304 ½-inch webbing length with the 3-inch long end of the folded webbing facedown and the folded end aligned with the 13-inch mark made in step c. above.
  - i. Beginning at the 3-inch mark, secure the folded webbing length by stitching as outlined in step e. above.
  - j. Insert the arming wire attaching loop on one end of the lanyard through the loop located at the top of the arming wire.
  - k. Pass the opposite end of the lanyard through the arming wire attaching loop and draw the lanyard length taut to form a tight attaching loop at the top of the arming wire.



END OF WORK PACKAGE



---

**UNIT MAINTENANCE**  
**ANCILLARY EQUIPMENT FOR LOW VELOCITY AIR DROP SYSTEMS (LVADS)**  
**PARACHUTE CONNECTOR**

---

**THIS TASK COVERS:**

- Inspect
  - Replace
- 

**Tools**

Calipers (Item 5, WP 0064 00)  
 File, Bastard, 10-IN. (Item 8, WP 0064 00)  
 File, Bastard, 12-IN. (Item 9, WP 0064 00)

**Materials/Parts**

Connector, Parachute (Item 1, WP 0075 00)  
 Lubricant, Solid Film (Item 20, WP 0125 00)

**Personnel Required**

92R (10) Parachute Rigger

**Equipment Condition**

Removed from the M-2 cargo release assembly.

Disassembled.

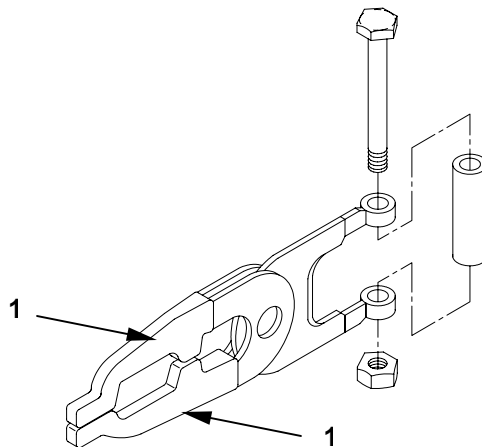
**References**

WP 0005 00

---

**INSPECT**

1. Inspect the parachute connector in accordance with WP 0005 00, using the procedures in Table 1.
2. Inspect the arm spacing.
  - a. Ensure that the arms **(1)** engage into the retainer clamp. If they do not, the thickness of the tips is too much.
  - b. The width of the tips of the arms should be between  $\frac{29}{32}$  and  $\frac{31}{32}$ -inches.
  - c. If the width is greater than  $\frac{31}{32}$ -inches, measure each arm individually. If either arm is larger than  $\frac{31}{64}$ -inches file the excess metal from the inside face of the arm to keep within allowable tolerances.
  - d. Place both arms together and check whether the total width is between  $\frac{29}{32}$  and  $\frac{31}{32}$ -inches. If they are not, repeat the procedure in step c., above.
  - e. Apply a coat of solid film lubricant to the exposed surfaces. Allow lubricant to dry for 24-hours before using connector.



**NOTE**

Do not touch exposed surfaces of metal with hands. Lubricant will not adhere to an oily surface.

**REPLACE**

Replace an unserviceable parachute connector with a serviceable one from stock.

**END OF WORK PACKAGE**

---

**UNIT MAINTENANCE  
ANCILLARY EQUIPMENT FOR LOW VELOCITY AIR DROP SYSTEMS (LVADS)  
TIMER DELAY ASSEMBLY**

---

**THIS TASK COVERS:**

- Inspect
  - Repair
  - Replace
- 

**Tools**

Screwdriver, Cross-Tip, No.1 (Item 27, WP 0064 00)  
Screwdriver, Flat-Tip,  $\frac{3}{16}$ -IN. (Item 30, WP 0064 00)

**Materials/Parts**

Crocus Cloth (Item 9, WP 0125 00)  
Timer Delay Assembly (Item 1, WP 0076 00)

**Personnel Required**

92R (10) Parachute Rigger

**Equipment Condition**

Removed from the M-2 cargo parachute release assembly.

**References**

WP 0005 00; WP 0079 00

---

**INSPECT**

1. Inspect the timer delay assembly in accordance with WP 0005 00, using the procedures in Table 1.
2. Check the timer delay.
  - a. With a screwdriver, turn stem **(1)**  $\frac{1}{4}$  turn to the right, as if arming in the release assembly, and let the time run down.

**NOTE**

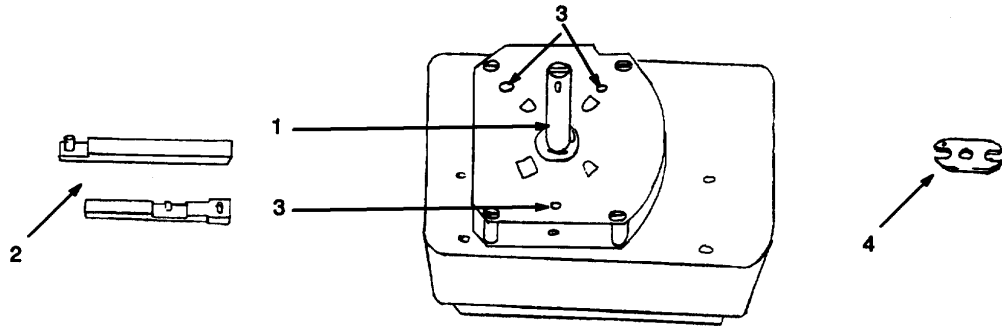
The interlock pin must be down before timer can be armed.

- b. If the time sequence is delayed in any way, check if the stem is binding on the mounting block. If so, loosen three screws and slightly move timer and stem assembly to remove binding. When free, retighten screws and recheck as in step a., above.
- c. Install mounting block with timer and stem assembly, making sure that the retraction pin goes into the hole in the key on the inside of the housing. (Ends of keys **(2)** must be retracted or even with the outside of the housing.) To check the retraction pin, again arm timer and stem assembly by turning the stem  $\frac{1}{4}$  turn to the right and checking if the keys extend from the housing on each end. Release the stem and allow the timer to run down, making sure that keys **(2)** retract when the timer runs down.

**REPAIR**

1. Disassemble timer delay assembly.

- a. Place timer delay on working area and remove the two screws holding mounting block to housing.



- b. Lift mounting block with timer and stem assembly out of housing.

**NOTE**

An internal interference problem with the timer delay assembly provided as a spare part component has been identified. The internal toggle makes contact with the key channel and prevents the timer from functioning properly and retracting the keys. The timer delay assembly can be identified by NSN 1670-01-099-2380, Part Number 11-1-894-1, Contract Number DAAJ09-83-C-B848, Cage Code 3N257, Hansen MFG. If found, dispose of IAW local procedures.

- c. Remove three screws (3) from outside holding timer assembly to mounting block.
- d. Lift damaged timing movement from timer block.
- e. Once identified, determine if there are signs of marks where the toggle has rubbed up against the channel in which the key slides. If found, the timer delay must be taken out of service and replaced.

2. Reassemble timer delay.

- a. Insert stem hole of new timer movement in mounting block. Rotate timer and stem assembly so three square sides are even with the top, end, and bottom sides of the mounting block.

**NOTE**

If the actuator pin (4) will not fit into the slot of the short key, clean the tip of the actuator pin with a crocus cloth.

- b. Insert mounting screws through three screw holes in mounting block into timer and stem.

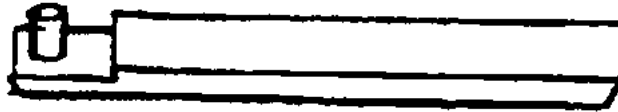
**NOTE**

The repair in step c. below, is an authorized expedient repair to enable continued use of the timer and stem assemblies in which the screw threads in the attachment plate have been damaged or stripped.

- c. Replace the mounting screws with screw NSN 5303-00-983-6730 and nut NSN 5310-00-811-6419. Place the new screws through the three screw holes in the mounting block through timer and stem attachment plate. Install nut on each screw and tighten until snug.
- d. Replace the two screws that hold the mounting block assembly to the housing. Re-inspect timer and stem assembly.

**REPLACE**

1. Replace damaged or missing time movement parts only as authorized by WP 0079 00.
2. Replace an unserviceable time movement with a serviceable item from stock.



**END OF WORK PACKAGE**





---

**UNIT MAINTENANCE**  
**ANCILLARY EQUIPMENT FOR LOW VELOCITY AIR DROP SYSTEMS (LVADS)**  
**TYPE IV SINGLE SUSPENSION LINK ASSEMBLY**

---

**THIS TASK COVERS:**

- Inspect
  - Replace
- 

**Tools**

None

**Personnel Required**

92R (10) Parachute Rigger

**Materials/Parts**

Link Assembly, Single Suspension, Type IV (Item 1, WP 0080 00)

**Equipment Condition**

Removed from the cargo parachute linkage.

**References**

WP 0005 00; WP 0007 00

---

**NOTE**

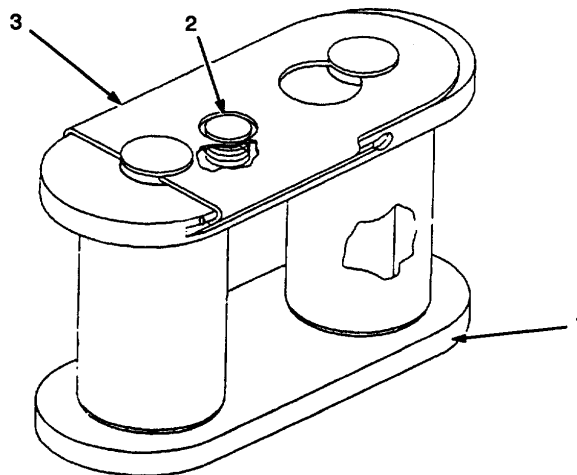
No longer authorized for LVAD after 31 December 2003.

**INSPECT**

Perform a technical/rigger-type inspection of the single suspension type IV link assembly in accordance with WP 0007 00 and WP 0005 00 using Table 1.

**REPLACE**

Replace an unserviceable single suspension type IV link with a serviceable item from stock.



**END OF WORK PACKAGE**



---

**UNIT MAINTENANCE**  
**ANCILLARY EQUIPMENT FOR LOW VELOCITY AIR DROP SYSTEMS (LVADS)**  
**HEAVY-DUTY LINK ASSEMBLY**

---

**THIS TASK COVERS:**

- Inspect
  - Replace
- 

**Tools**

Wrench, Open-End, 1 ½ and 1 ¾-IN. (Item 53, WP 0064 00)  
Wrench, Open-End, 1 7/16 and 1 5/8-IN. (Item 56, WP 0064 00)

**Materials/Parts**

Link Assembly, Heavy-Duty (Item 1, WP 0081 00)

**Personnel Required**

92R (10) Parachute Rigger

**Equipment Condition**

Removed from the cargo parachute linkage.

**References**

WP 0005 00; WP 0007 00;  
WP 0081 00

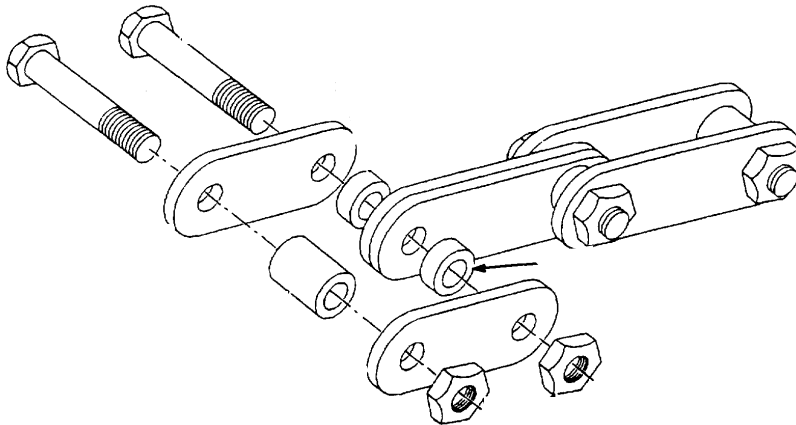
---

**INSPECT**

Perform a technical/rigger-type inspection of the heavy-duty link assembly in accordance with WP 0007 00 and Table 1, WP 0005 00.

**REPLACE**

1. Replace damaged or missing heavy-duty link assembly parts only as authorized by WP 0081 00.
2. Replace an unserviceable heavy-duty link assembly with a serviceable item from stock.



**END OF WORK PACKAGE**



---

**UNIT MAINTENANCE**  
**ANCILLARY EQUIPMENT FOR LOW VELOCITY AIR DROP SYSTEMS (LVADS)**  
**4-POINT LINK**

---

**THIS TASK COVERS:**

- Inspect
  - Replace
- 

**Tools**

Wrench, Open-End, 1 ½ and 1 ¾-IN. (Item 53, WP 0064 00)  
Wrench, Open-End, 1 7/16 and 1 5/8-IN. (Item 56, WP 0064 00)

**Materials/Parts**

Link, 4 Point (Item 1, WP 0082 00)

**Personnel Required**

92R (10) Parachute Rigger

**Equipment Condition**

Removed from the cargo parachute linkage.

**References**

WP 0005 00; WP 0007 00;  
WP 0082 00

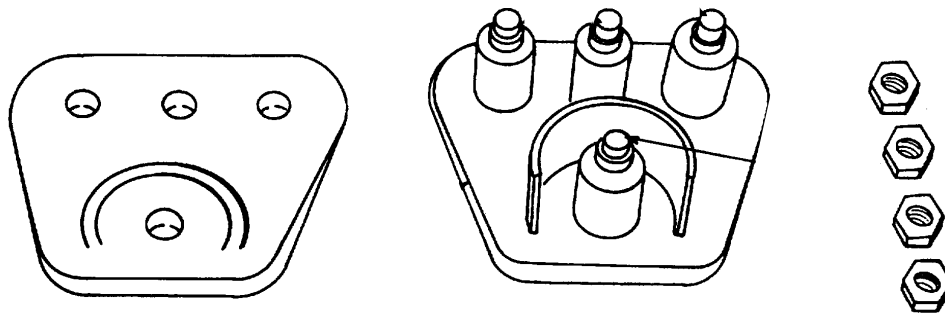
---

**INSPECT**

Perform a technical/rigger-type inspection of the four-point link in accordance with WP 0007 00 and Table 1, WP 0005 00.

**REPLACE**

1. Replace damaged or missing four-point link parts only as authorized by WP 0082 00.
2. Replace an unserviceable arm clustering assembly with a serviceable item from stock.



**END OF WORK PACKAGE**



---

**UNIT MAINTENANCE**  
**ANCILLARY EQUIPMENT FOR LOW VELOCITY AIR DROP SYSTEMS (LVADS)**  
**TYPE IV LINK COVER**

---

**THIS TASK COVERS:**

- Inspect
  - Replace
- 

**Materials/Parts**

Cord, Nylon, Type III (Item 7, WP 0125 00)  
Cover, Link, Type IV (Item 1, WP 0083 00)

**Equipment Condition**

Removed from the cargo parachute linkage.

**Tools**

Knife, Hot Metal (Item 18, WP 0064 00)  
Shears (Item 42, WP 0064 00)

**References**

WP 0005 00; WP 0007 00

**Personnel Required**

92R (10) Parachute Rigger

---

NOTE

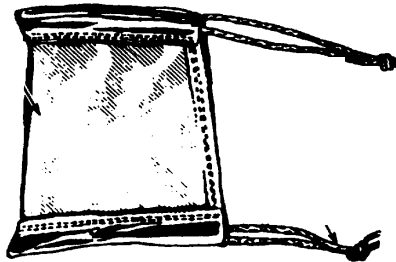
No longer authorized for LVAD after 31 December 2003.

**INSPECT**

Perform a technical/rigger-type inspection of the type IV link cover in accordance with WP 0007 00 and Table 1, WP 0005 00.

**REPLACE**

1. Replace a defective drawstring cord.
  - a. Cut the overhand knot on the defective cord.
  - b. Slide the damaged cord out of the sewn channel.
  - c. Cut a 24- or 28-inch length of type III nylon cord as applicable and sear both ends. Make sure that the seared edge is not sharp or lumpy.
  - d. Insert one end of the replacement cord into the sewn channel. Make sure that the ends are even.
  - e. Tie the loose ends of the cord together with an overhand knot.
2. Replace an unserviceable type IV link cover with a serviceable item from stock.



**END OF WORK PACKAGE**





---

**UNIT MAINTENANCE**  
**ANCILLARY EQUIPMENT FOR LOW VELOCITY AIR DROP SYSTEMS (LVADS)**  
**AERIAL DELIVERY CLEVIS**

---

**THIS TASK COVERS:**

- Inspect
  - Replace
- 

**Tools**

Wrench, Open-End, 1 ¼ and 1 5/16-IN. (Item 52, WP 0064 00)  
Wrench, Open-End, 1 ½ and 1 ¾-IN. (Item 53, WP 0064 00)  
Wrench, Open-End, 1 5/16 and 1-IN. (Item 59, WP 0064 00)

**Materials/Parts**

Clevis, Aerial Delivery (Item 1, WP 0084 00)

**Personnel Required**

92R (10) Parachute Rigger

**Equipment Condition**

Removed from the cargo parachute linkage

**References**

WP 0005 00; WP 0007 00;  
WP 0084 00

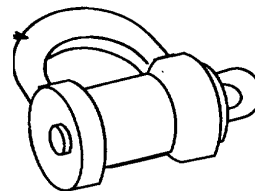
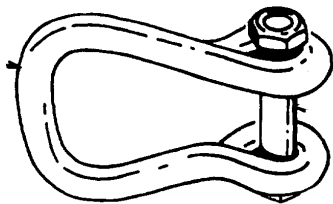
---

**INSPECT**

Perform a technical/rigger-type inspection of the aerial delivery clevis in accordance with WP 0007 00 and Table 1, WP 0005 00.

**REPLACE**

1. Replace damaged or missing aerial delivery clevis parts only as authorized by WP 0084 00.
2. Replace an unserviceable aerial delivery clevis with a serviceable item from stock.



**END OF WORK PACKAGE**



---

**UNIT MAINTENANCE**  
**ANCILLARY EQUIPMENT FOR LOW VELOCITY AIR DROP SYSTEMS (LVADS)**  
**CLEVIS COVER**

---

**THIS TASK COVERS:**

- Inspect
  - Replace
- 

**Tools**

Grommet Punch (Item 11, WP 0064 00)

**Materials/Parts**

Cover, Clevis (Item 2, WP 0085 00)

**Personnel Required**

92R (10) Parachute Rigger

**Equipment Condition**

Removed from the cargo parachute linkage.

**References**

WP 0005 00; WP 0007 00

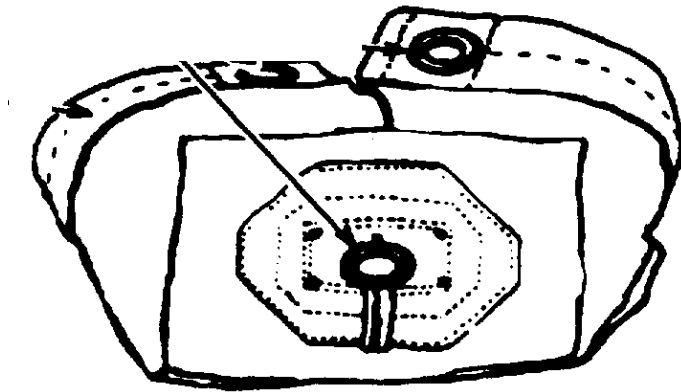
---

**INSPECT**

Perform a technical/rigger-type inspection of the clevis cover in accordance with WP 0007 00 and Table 1, WP 0005 00.

**REPLACE**

Replace an unserviceable clevis cover with a serviceable item from stock.



**END OF WORK PACKAGE**



---

**UNIT MAINTENANCE**  
**ANCILLARY EQUIPMENT FOR LOW VELOCITY AIR DROP SYSTEMS (LVADS)**  
**SINGLE KNIFE PARACHUTE RELEASE STRAP**

---

**THIS TASK COVERS:**

- Inspect
  - Replace
- 

**Tools**

Stone, Sharpening, Round (Item 44, WP 00??64 00)

**Personnel Required**

92R (10) Parachute Rigger

**Materials/Parts**

Strap, Parachute Release, Single Knife (Item 1, WP 0086 00)

**Equipment Condition**

Removed from the cargo parachute linkage.

**References**

WP 0005 00; WP 0007 00

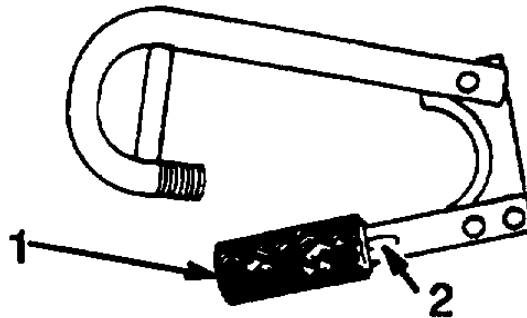
---

**INSPECT**

1. Perform a technical/rigger-type inspection of the single knife parachute strap in accordance with WP 0007 00 and Table 1, WP 0005 00.

NOTE

When the ferrule (1) of a guillotine knife had been unscrewed to the full open position, the safety hole (2) should be covered. If the aperture is not covered, the item is unserviceable.



2. Sharpen a dull knife blade with a round sharpening stone.

**REPLACE**

Replace an unserviceable single knife parachute strap with a serviceable item from stock.

**END OF WORK PACKAGE**



---

**UNIT MAINTENANCE**  
**ANCILLARY EQUIPMENT FOR LOW VELOCITY AIR DROP SYSTEMS (LVADS)**  
**MULTI-KNIFE PARACHUTE RELEASE STRAP**

---

**THIS TASK COVERS:**

- Inspect
  - Replace
- 

**Tools**

Stone, Sharpening, Round (Item 44, WP 0064 00)

**Materials/Parts**

Strap, Parachute Release, Multi-Knife (Item 1, WP 0087 00)

**Personnel Required**

92R (10) Parachute Rigger

**Equipment Condition**

Removed from the cargo parachute linkage.

**References**

WP 0005 00; WP 0007 00

---

**INSPECT**

1. Perform a technical/rigger-type inspection of the single knife parachute strap in accordance with WP 0007 00 and Table 1, WP 0005 00.

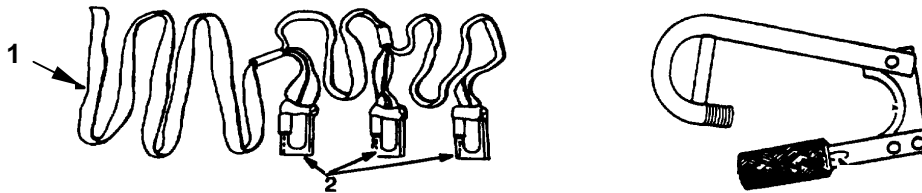
NOTE

When the ferrule (1) of a guillotine knife had been unscrewed to the full open position, the safety hole (2) should be covered. If the aperture is not covered, the item is unserviceable.

2. Sharpen a dull knife blade with a round sharpening stone.

**REPLACE**

Replace an unserviceable multi-knife parachute strap with a serviceable item from stock.



**END OF WORK PACKAGE**





---

**UNIT MAINTENANCE**  
**ANCILLARY EQUIPMENT FOR LOW VELOCITY AIR DROP SYSTEMS (LVADS)**  
**3-POINT COUPLING LINK ASSEMBLY COUPLING**

---

**THIS TASK COVERS:**

- Inspect
  - Replace
- 

**Tools**

Wrench, Open-End, 1 ½ and 1 ¾-IN. (Item 53, WP 0064 00)  
Wrench, Open-End, 1 7/16 and 1 5/8-IN. (Item 56, WP 0064 00)

**Materials/Parts**

Link Assembly, Coupling, 3-Point (Item 1, WP 0088 00)

**Personnel Required**

92R (10) Parachute Rigger

**Equipment Condition**

Removed from the cargo parachute linkage.

**References**

WP 0005 00; WP 0007 00;  
WP 0088 00

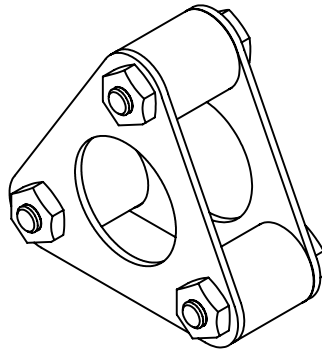
---

**INSPECT**

Perform a technical/rigger-type inspection of the three-point link assembly in accordance with WP 0007 00 and Table 1, WP 0005 00.

**REPLACE**

1. Replace damaged or missing three-point link assembly parts only as authorized by WP 0088 00.
2. Replace an unserviceable three-point link assembly with a serviceable item from stock.



**END OF WORK PACKAGE**



---

**UNIT MAINTENANCE**  
**ANCILLARY EQUIPMENT FOR LOW VELOCITY AIR DROP SYSTEMS (LVADS)**  
**M-35 SUSPENSION BRACKET**

---

**THIS TASK COVERS:**

- Inspect
  - Replace
- 

**Tools**

None

**Materials/Parts**

Bracket, Suspension (Item 1, WP 0089 00)

**Personnel Required**

92R (10) Parachute Rigger

**Equipment Condition**

Removed from the cargo parachute linkage

**References**

WP 0005 00; WP 0007 00

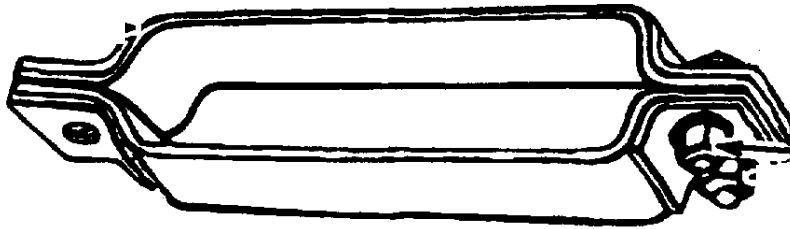
---

**INSPECT**

Perform a technical/rigger-type inspection of the M-35 suspension bracket in accordance with WP 0007 00 and Table 1, WP 0005 00.

**REPLACE**

Replace an unserviceable M-35 suspension bracket with a serviceable item from stock.



**END OF WORK PACKAGE**



---

**UNIT MAINTENANCE**  
**ANCILLARY EQUIPMENT FOR LOW VELOCITY AIR DROP SYSTEMS (LVADS)**  
**M-59 SUSPENSION BRACKET**

---

**THIS TASK COVERS:**

- Inspect
  - Replace
- 

**Tools**

None

**Materials/Parts**

Bracket, Suspension (Item 1, WP 0090 00)

**Personnel Required**

92R (10) Parachute Rigger

**Equipment Condition**

Removed from the cargo parachute linkage

**References**

WP 0005 00; WP 0007 00

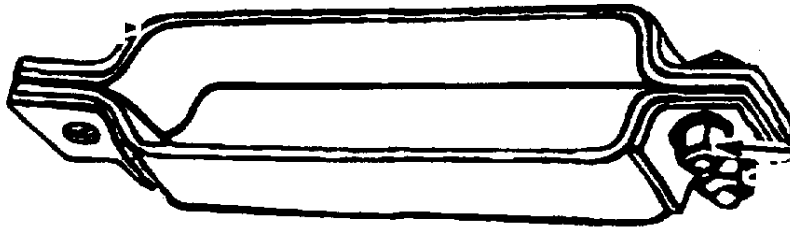
---

**INSPECT**

Perform a technical/rigger-type inspection of the M-59 suspension bracket in accordance with WP 0007 00 and Table 1, WP 0005 00.

**REPLACE**

Replace an unserviceable M-59 suspension bracket with a serviceable item from stock.



**END OF WORK PACKAGE**



---

**UNIT MAINTENANCE  
ANCILLARY EQUIPMENT FOR LOW VELOCITY AIR DROP SYSTEMS (LVADS)  
SUSPENSION PLATE**

---

**THIS TASK COVERS:**

- Inspect
  - Replace
- 

**Tools**

None

**Materials/Parts**

Plate, Suspension (Item 1, WP 0091 00)

**Personnel Required**

92R (10) Parachute Rigger

**Equipment Condition**

Removed from the cargo parachute linkage.

**References**

WP 0007 00

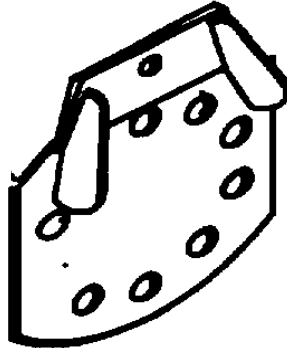
---

**INSPECT**

Perform a technical/rigger-type inspection of the suspension plate in accordance with WP 0007 00.

**REPLACE**

Replace an unserviceable suspension plate with a serviceable item from stock.



**END OF WORK PACKAGE**





---

**UNIT MAINTENANCE  
ANCILLARY EQUIPMENT FOR LOW VELOCITY AIR DROP SYSTEMS (LVADS)  
10K CARGO TIE-DOWN**

---

**THIS TASK COVERS:**

- Inspect
  - Replace
- 

**Materials/Parts**

Tie-down, Cargo, 10K (Item 1, WP 0092 00)

**Personnel Required**

92R (10) Parachute Rigger

**References**

WP 0005 00; WP 0007 00; WP 0092 00

**Equipment Condition**Removed from the cargo parachute linkage.

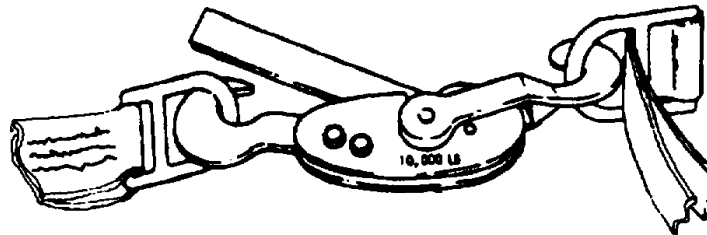
---

**INSPECT**

Perform a technical/rigger-type inspection of the 10K cargo tie-down in accordance with WP 0007 00 and Table 1, WP 0005 00.

**REPLACE**

1. Replace damaged or missing 10K cargo tie-down parts only as authorized by WP 0092 00.
2. Replace an unserviceable 10K cargo tie-down with a serviceable item from stock.

**END OF WORK PACKAGE**



---

**UNIT MAINTENANCE**  
**ANCILLARY EQUIPMENT FOR LOW VELOCITY AIR DROP SYSTEMS (LVADS)**  
**QUICK-RELEASE CARGO TIE-DOWN**

---

**THIS TASK COVERS:**

- Inspect
  - Replace
- 

**Tools**

None

**Materials/Parts**

Tie-down, Cargo, Quick-Release (Item 1, WP 0093 00)

**Personnel Required**

92R (10) Parachute Rigger

**Equipment Condition**

Removed from the cargo parachute linkage.

**References**

WP 0005 00; WP 0007 00

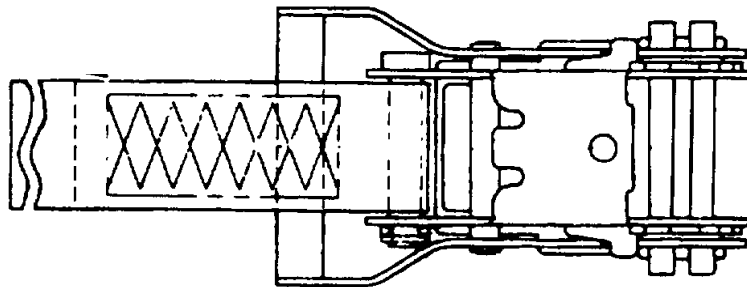
---

**INSPECT**

Perform a technical/rigger-type inspection of the quick-release cargo tie-down in accordance with WP 0007 00 and Table 1, WP 0005 00.

**REPLACE**

Replace an unserviceable quick-release cargo tie-down with a serviceable item from stock.



**END OF WORK PACKAGE**



---

**UNIT MAINTENANCE  
ANCILLARY EQUIPMENT FOR LOW VELOCITY AIR DROP SYSTEMS (LVADS)  
TYPE IV DRIVE OFF AID**

---

**THIS TASK COVERS:**

- Inspect
  - Replace
- 

**Tools**

None

**Personnel Required**

92R (10) Parachute Rigger

**Materials/Parts**

Drive Off Aid, Type IV (Item 1, WP 0094 00)

**Equipment Condition**

Fully assembled.

**References**

WP 0005 00; WP 0007 00

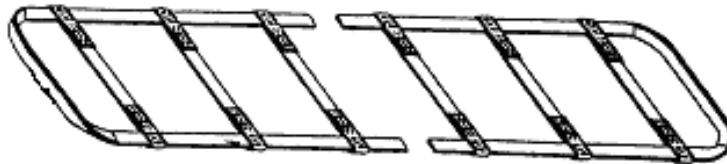
---

**INSPECT**

Perform a technical/rigger-type inspection of the type IV drive-off aid in accordance with WP 0007 00 and Table 1, WP 0005 00.

**REPLACE**

Replace an unserviceable drive-off aid with a serviceable item from stock.



**END OF WORK PACKAGE**



---

**UNIT MAINTENANCE**  
**ANCILLARY EQUIPMENT FOR LOW VELOCITY AIR DROP SYSTEMS (LVADS)**  
**AIRCRAFT CARGO TIE-DOWN**

---

**THIS TASK COVERS:**

- Inspect
  - Replace
- 

**Tools**

None

**Materials/Parts**

Tie-down, Cargo, Aircraft (Item 1, WP 0095 00)

**Personnel Required**

92R (10) Parachute Rigger

**Equipment Condition**

Fully assembled.

**References**WP 0005 00; WP 0007 00;  
WP 0095 00

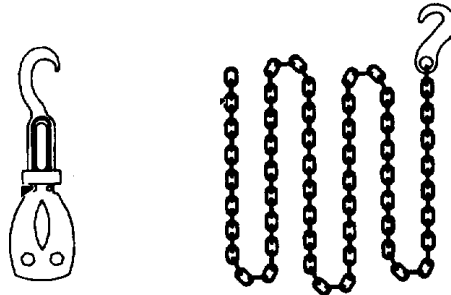
---

**INSPECT**

Perform a technical/rigger-type inspection of the 10K cargo tie-down in accordance with WP 0007 00 and Table 1, WP 0005 00.

**REPLACE**

1. Replace damaged or missing aircraft cargo tie-down parts only as authorized by WP 0095 00.
2. Replace an unserviceable aircraft cargo tie-down with a serviceable item from stock.

**END OF WORK PACKAGE**





---

**UNIT MAINTENANCE**  
**ANCILLARY EQUIPMENT FOR LOW VELOCITY AIR DROP SYSTEMS (LVADS)**  
**3 3/4-INCH, 2-POINT LINK**

---

**THIS TASK COVERS:**

- Inspect
  - Replace
- 

**Tools**

Wrench, Open End, 1-IN. and 1 1/8-IN. (Item 57, WP 0064 00)

**Personnel Required**

92R (10) Parachute Rigger

**Materials/Parts**

None

**References**

WP 0005 00; WP 0007 00;  
WP 0096 00

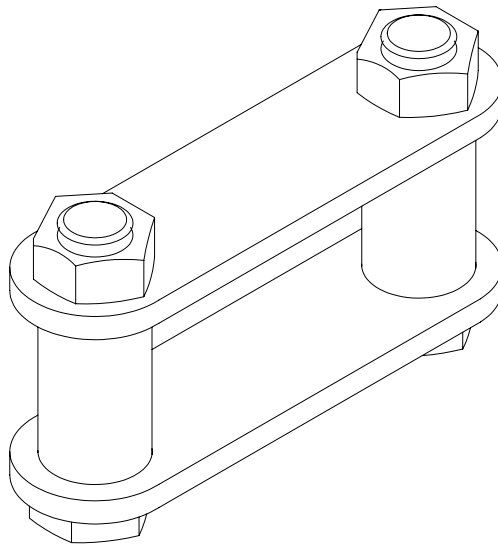
---

**INSPECT**

Perform a technical/rigger-type inspection of the 3 3/4-inch 2-point link in accordance with WP 0007 00 and Table 1, WP 0005 00.

**REPLACE**

1. Replace damaged or missing 3 3/4-inch, 2-point link parts only as authorized by WP 0096 00.
2. Replace an unserviceable 3 3/4-inch, 2-point link with a serviceable item from stock.



**END OF WORK PACKAGE**



---

**UNIT MAINTENANCE**  
**ANCILLARY EQUIPMENT FOR LOW VELOCITY AIR DROP SYSTEMS (LVADS)**  
**5 ½-INCH, 2-POINT LINK**

---

**THIS TASK COVERS:**

- Inspect
  - Replace
- 

**Tools**

Wrench, Open End, 1-IN. and 1 ⅛-IN. (Item 57, WP 0064 00)

**Materials/Parts**

None

**Personnel Required**

92R (10) Parachute Rigger

**References**

WP 0005 00; WP 0007 00;  
WP 0097 00

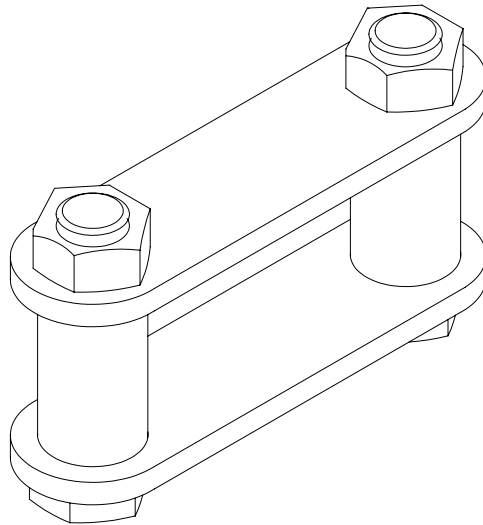
---

**INSPECT**

Perform a technical/rigger-type inspection of the 5 ½-inch, 2-point link in accordance with WP 0007 00 and Table 1, WP 0005 00.

**REPLACE**

1. Replace damaged or missing 5 ½-inch, 2-point link parts only as authorized by WP 0097 00.
2. Replace an unserviceable 5 ½-inch, 2-point link with a serviceable item from stock.



**END OF WORK PACKAGE**



---

**UNIT MAINTENANCE  
ANCILLARY EQUIPMENT FOR LOW VELOCITY AIR DROP SYSTEMS (LVADS)  
RELEASE AWAY STATIC LINE ASSEMBLY**

---

**THIS TASK COVERS:**

- Inspect
  - Replace
- 

**Tools**

Knife, Pocket (Item 19, WP 0064 00)  
Screwdriver, Cross-Tip, No. 2 (Item 28, WP 0064 00)

**Materials/Parts**

None

**Personnel Required**

92R (10) Parachute Rigger

**References**

WP 0005 00; WP 0007 00;  
WP 0098 00

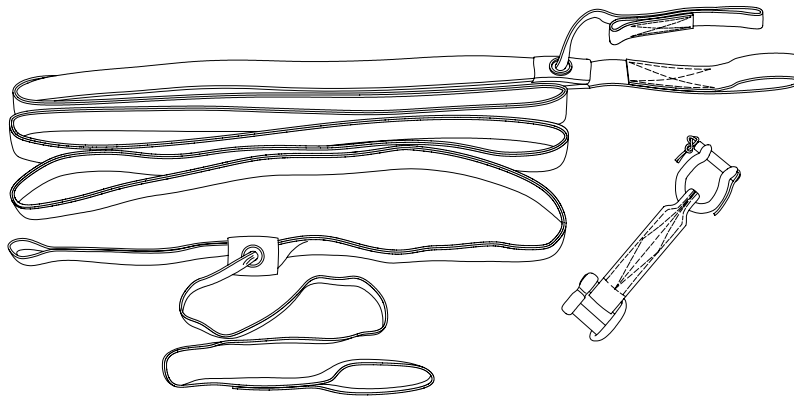
---

**INSPECT**

Perform a technical/rigger-type inspection of the release away static line assembly in accordance with WP 0007 00 and Table 1, WP 0005 00.

**REPLACE**

1. Replace damaged or missing release away static line assembly parts only as authorized by WP 0098 00.
2. Replace an unserviceable release away static line assembly with a serviceable item from stock.



**END OF WORK PACKAGE**



**UNIT MAINTENANCE  
 ANCILLARY EQUIPMENT FOR LOW VELOCITY AIR DROP SYSTEMS (LVADS)  
 EXTRACTION PARACHUTE JETTISON SYSTEM (EPJS)**

**THIS TASK COVERS:**

- Inspect
- Assemble
- Test
- Disassemble

**Tools**

Power Supply, 28 VDC (Item 25, WP 0064 00)  
 Simulator, Initiator (Item 43, WP 0064 00)

**Personnel Required**

92R (10) Parachute Rigger

**Materials/Parts**

None

**References**

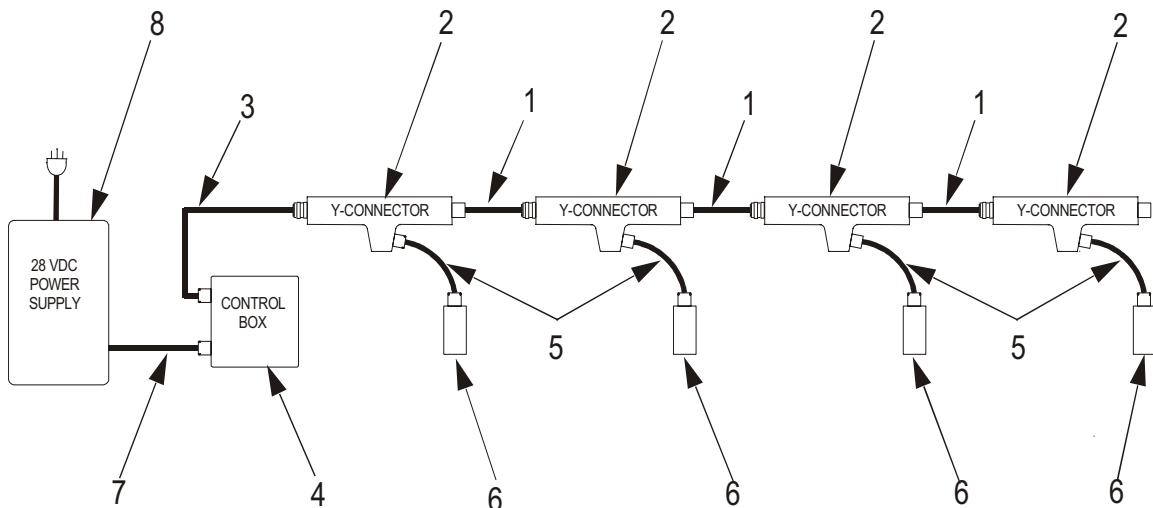
WP 0005 00; WP 0007 00

**INSPECT**

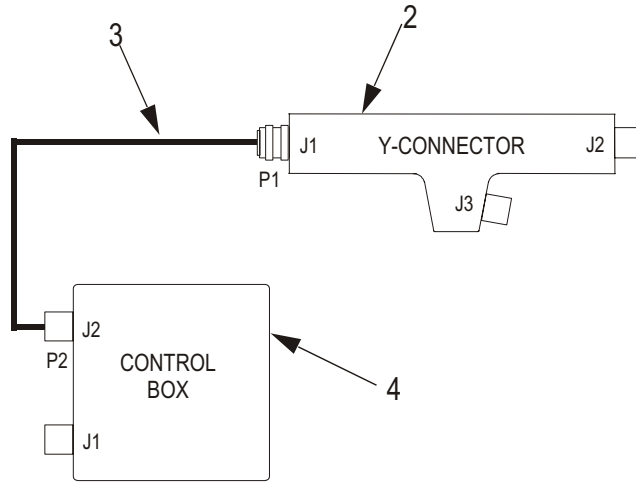
Perform a technical/rigger type inspection of the EPJS in accordance with WP 0007 00 and WP 0005 00, Table 1.

**ASSEMBLE**

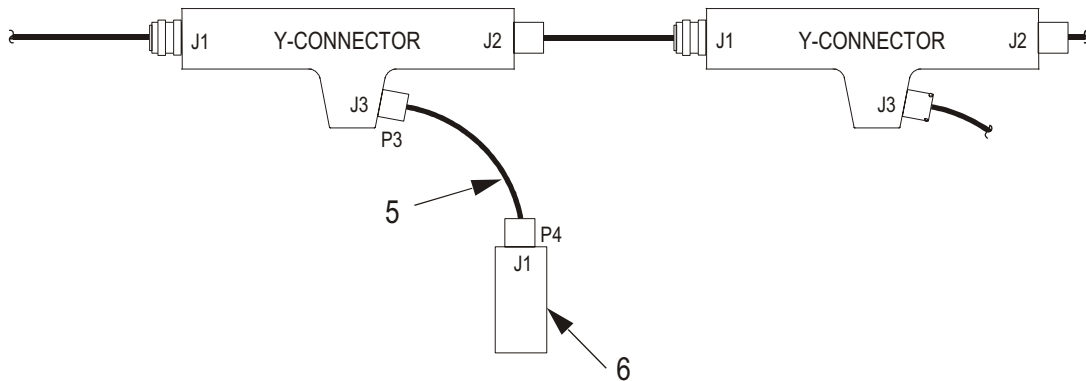
1. Remove all cables from kit bag (not shown).
2. Remove Y-connectors (2) and Y-connector mounting boxes (not shown) from kit bag.
3. Remove control box (4) from kit bag.
4. In a suitable area, layout Y-connector mounting boxes, with Y-connectors (2) installed.
5. Ensure all Y-connector mounting boxes are facing the same direction as indicated by the FWD arrows stenciled on the Y-connector mounting boxes.
6. Install interconnect cables (1) to Y-connectors (2) (P1 connects to J1; and P2 connects to J2).



7. Install the 50-foot main cable (3) between the first Y-connector (2) and control box (4) (P1 connects to J1 on Y-connector; P2 connects to control box TO LOADS J2 connector).



8. Retrieve and connect four platform cables (5) to initiator simulators (6) (P3 on platform cable connects to J3 on Y-connector; P4 on platform cable connects to J1 on initiator simulator).



**NOTE**

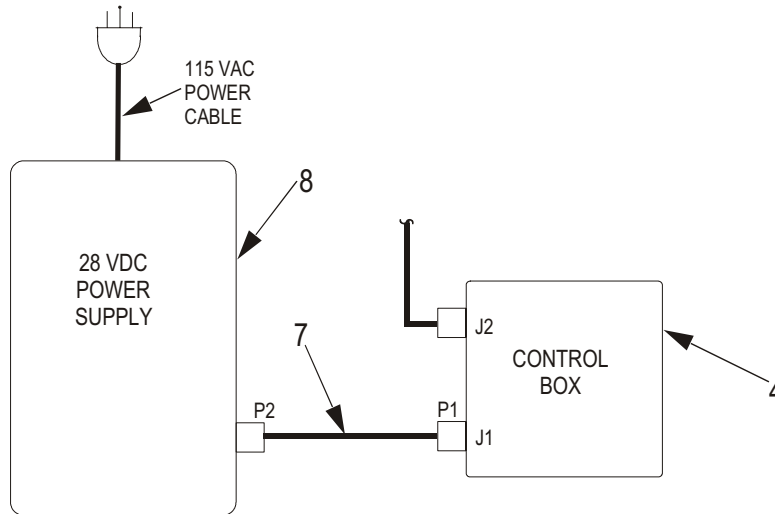
Ensure 28 VDC power supply is turned OFF and unplugged prior to connecting to EPJS.

**NOTE**

Initiator simulators will be used in place of squibs to functionally test the system. Each initiator simulator uses two 1-AMP circuit breakers to simulator the dual bridge wire in the squib.



9. Install power cable (7) between control box (4) and 28 VDC power supply (8) (P1 connects to 28 VDC power input J1; P2 connects to 28 VDC POWER SUPPLY).



## TEST

1. Set control box POWER and JETTISON switches to OFF.
2. Ensure control box circuit breaker is set (pushed in).
3. Rotate DIMMER control to full on position.
4. Plug 28 VDC power supply into 115 VAC power.
5. Set all initiator simulator circuit breakers to ON.
6. Set 28 VDC POWER switch to ON.
7. Set control box POWER switch to ON. Verify that all four LEDs on control box are illuminated. Verify that the LED on each Y-connector is illuminated. If conditions are not met, proceed to subsets a. through d. If conditions are met, proceed to step 8.
  - a. Verify LED is operable by pressing appropriate LAMP TEST switch.
  - b. Verify cabling is properly connected.
  - c. Verify initiator simulator circuit breakers are set to ON.
  - d. If necessary, replace suspected initiator simulator, platform cable and/or Y-connector.
8. Set JETTISON SWITCH, on control box to JETTISON. Verify that all breakers on initiator simulators have tripped (OFF position). If no breaker on any initiator trips, the control box is defective and must be replaced. If the breaker(s) on only one initiator simulator does not trip, the associated Y-connector of the initiator simulator is defective and must be replaced. Proceed as follows:



---

**UNIT MAINTENANCE**  
**ANCILLARY EQUIPMENT FOR LOW VELOCITY AIR DROP SYSTEMS (LVADS)**  
**EXTRACTION PARACHUTE JETTISON DEVICE (EPJD), SQUIB, AND SQUIB CABLE**

---

**THIS TASK COVERS:**

- Inspect
- Test
- Replace

---

**Tools**

Initiator Simulator (Item 1, WP 0118 00)  
Kit, Tool, Refurbish, EPJD (Item 1, WP 0122 00)  
Tester, Squib (Item 1, WP 0119 00)

**Materials/Parts**

Cap, Safety (Item 1, WP 0117 00)  
Dishwashing Compound (Item 10, WP 0064 00)  
Kit, Refurbish (Item 15, WP 0064 00)  
Lube, O-Ring (Item 19, WP 0064 00)  
Protective Cover (Item 1, WP 0111 00)  
Rag, Wiping (Item 25, WP 0064 00)  
Squib Assembly (Item 1, WP 0105 00)

**Personnel Required**

92R (10) Parachute Rigger

**References**

WP 0005 00; WP 0007 00;  
WP 0059 00

---

**INSPECT**

Perform a technical/rigger type inspection of EPJD, squib, and squib cable in accordance with WP 0007 00 and WP 0005 00, Table 1.

**TEST**

1. Test Squib Tester.
  - a. Test squib tester in accordance with procedures in WP 0059 00.
  - b. Place squib tester POWER switch in the OFF position.
  - c. Place squib tester CIRCUIT SELECT switch in the A-B position.
2. Test Squib Cable.
  - a. Retrieve squib cable **(3)** to be tested.
  - b. Inspect squib cable **(3)** in accordance with WP 005 00.
  - c. Attach squib cable **(3)** J5 connector end to port J2 on initiator simulator. Ensure that initiator simulator circuit breaker switches are in the ON position.
  - d. Attach squib tester to squib cable **(3)** end J4.
  - e. Place squib tester CIRCUIT SELECT switch in the ON position. Observe LED lights.
    - (1) If any squib tester LED lights come on, replace squib cable.
    - (2) If any squib tester LED lights go off and on or flash with movement of cable, replace the squib cable.
    - (3) If squib tester LED lights stay off proceed to next step.

- f. Place squib tester CIRCUIT SELECT switch in the C-D position.

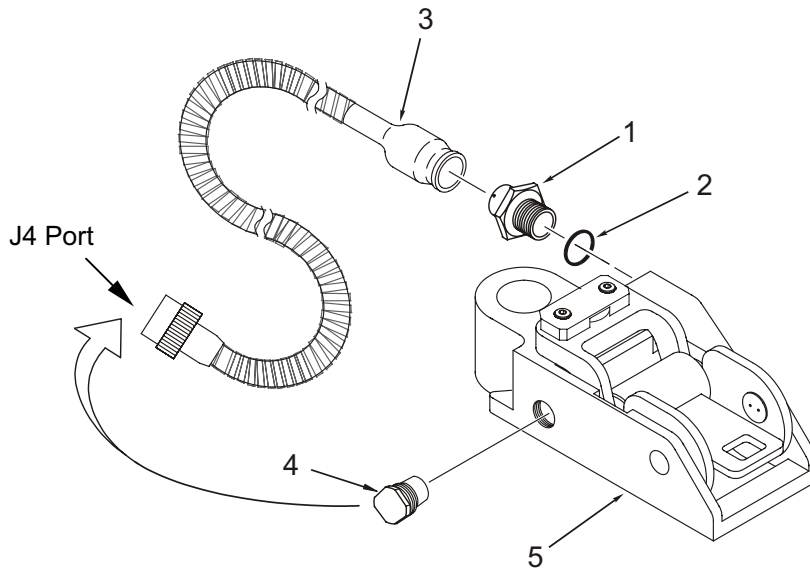
**NOTE**

When moving the squib tester CIRCUIT SELECT switch to another position the squib tester LED lights may flash briefly.

- (1) If any squib tester LED lights come on, replace squib cable.
  - (2) If any squib tester LED lights come on or flash with movement, replace squib cable.
  - (3) If squib tester LED lights stay off proceed to next step.
- g. Place squib tester CIRCUIT SELECT switch in A-B position.
- h. Place squib tester POWER switch in OFF position.
- i. Disconnect squib tester from squib cable **(3)** and install safety cap **(4)** on squib cable J4 port.

**NOTE**

Match alignment keys on the cable to the alignment slots on the safety cap.



- j. Disconnect squib cable **(3)** from initiator simulator.

### 3. Test Squib and Squib Cable Assembly.

#### WARNING

The squib is a pyrotechnic device. When not installed in aircraft, and all cabling and equipment is not installed, then squib cable safety cap must be installed on squib cable. Use care when handling the squib to prevent accidental firing of the device. Avoid dropping or jarring the squib and avoid static electricity. Failure to follow precautions can result in injury to personnel.

#### WARNING

Wear safety goggles when handling the squib.

- a. In an area away from electrical equipment, remove squib **(1)** from storage container. Examine squib for evidence of damage.
- b. Remove squib packaging and two plastic caps.
- c. Apply a light coating of O-ring lube to O-ring **(2)**.
- d. Remove shorting clip from male pin side of squib **(1)**. Inspect to ensure that the stainless steel covering on threaded end of squib is present and is free of damage.
- e. Ensure safety cap is in place on squib cable J4 port. Attach squib **(1)** to squib cable **(3)** end J5.

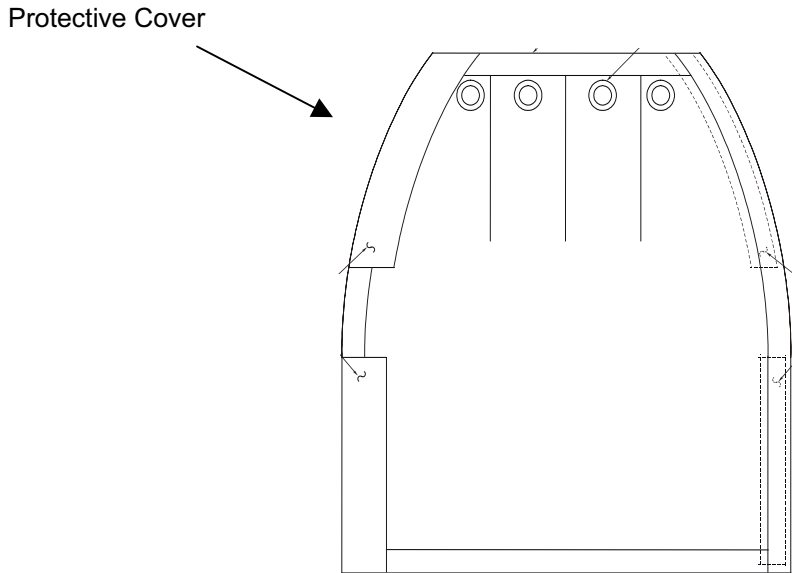
#### WARNING

Before squib is installed in EPJD housing, ensure that the latch on EPJD is retained by latch retainer.

#### WARNING

Squib must be installed with Squib Cable **(3)** and Safety Cap **(4)** installed. **DO NOT SEPARATE SQUIB CABLE WITH SAFETY CAP FROM SQUIB.** Failure to follow precautions can result in injury to personnel.

- f. Install squib **(1)** into EPJD housing **(5)**. Snug squib **(1)** in place with a 1-inch open end wrench.
- g. Place the protective cover over EPJD allowing for access to end of squib cable **(3)**.



**WARNING**

After the squib has been installed in the EPJD, handle the EPJD from the bottom only. Failure to do so can result in injury to personnel. Ensure the protective cover is around the EPJD.

- h. Ensure the squib tester CIRUIT SELECT switch is in the A-B position. Ensure the squib tester POWER switch is in the OFF position.
- i. Remove the safety cap **(4)** from the squib cable **(3)**.
- j. Attach squib tester to the squib cable **(3)**.
- k. Observe LED lights.
  - (1) If any squib tester LED lights come on, replace squib **(1)**.
  - (2) If any squib tester LED lights come on or flashes with movement, replace the squib **(1)**.
  - (3) If squib tester LED lights stay off, proceed to the next step.
- l. Place the squib tester CIRUIT SELECT switch in the C-D position.

NOTE

When moving the squib tester CIRCUIT SELECT switch to another position the squib tester LED lights may flash briefly.

- m. Observe LED lights.
  - (1) If any squib tester LED lights come on, replace squib (1).
  - (2) If any squib tester LED lights come on or flash with movement, replace squib (1).
  - (3) If squib tester LED lights stay off, squib and squib cable assembly is acceptable for use.
- n. Place squib tester CIRCUIT SELECT switch in A-B position.
- o. Place squib tester POWER switch in OFF position.
- p. Disconnect squib tester from squib cable (3).
- q. Replace safety cap (4) onto squib cable (3) end J4.

## REPAIR

After a squib has been fired, refurbish prior to next use as follows:

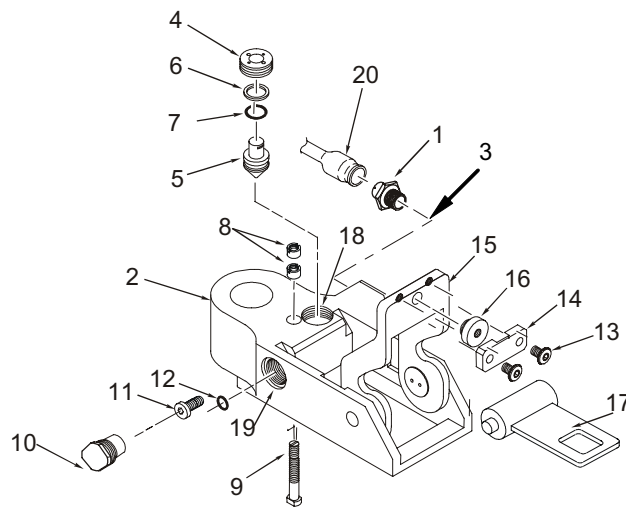
1. Disassemble.
  - a. If installed, remove squib cable (20) from squib (1).
  - b. Using 1-inch wrench, remove squib (1) from housing (2). Remove and discard preformed packing (3).
  - c. Using piston stop/shear bolt retainer wrench, remove piston stop (4) and piston (5). Remove and discard backup ring (6) and preformed packing (7).
  - d. Using piston stop/shear bolt retainer wrench, remove the two shear bolt retainers (8) and shear bolt (9) (shear bolt is removed from the bottom of the EPJD).
  - e. Remove safety cap (10).
  - f. Using T-handled hex driver, remove cross hole plug (11). Remove and discard preformed packing (12).
  - g. Remove screws (13) and retainer clamp (14) from latch (15).
  - h. Remove latch retainer (16) from latch (15) and discard. If installed, remove keeper (17) from latch.

## 2. Clean.

- a. Clean the inside bores (18) of housing (2) that contained the piston (5), and the squib (1). Use warm water, mild liquid detergent, and large diameter bristle brush.
- b. Clean small diameter bore (19) used for cross hole plug (11). Use warm water, a mild liquid detergent, and small diameter bristle brush.
- c. Rinse with clean water and dry thoroughly with a clean, lint-free cloth.

## 3. Assemble.

- a. Apply a light coating of O-ring lube to new preformed packing (7) and backup ring (6). Install backup ring, then preformed packing onto piston (5).



- b. Place piston (5) in top bore (18) and screw in piston stop (4) by hand. Rotate latch (15) closed and apply pressure on latch to seat piston into bore (18). Using piston stop/shear bolt retainer wrench, tighten piston stop (4).
- c. Install new shear bolt (9) and retainers (8) into housing (2). Shear bolt should be installed from the bottom of the EPJD. Retainers should be placed on bolt, notch side up, and installed one at a time. Make sure each retainer is snug. Use piston stop/shear bolt retainer to facilitate installation of retainers and shear bolt.
- d. Install latch retainer (16) and keeper (17) onto latch.
- e. Rotate latch (15) onto housing (2) and screw latch retainer (16) onto shear bolt (9).
- f. Apply a light coating of O-ring lube to new preformed packing (12) and install on cross hole plug (11).
- g. Using T-handle hex driver, thread cross hole plug (11) into side bore (19). Do not tighten at this time.
- h. Torque cross hole plug (11) to 72-inch pounds.
- i. Install retainer clamp (14) in place over latch retainer (16), and secure with two screws (13)



- 
- j. Test squib in accordance with the TEST procedures detailed in this WP.

**WARNING**

Squib must be installed with squib cable and safety cap installed. DO NOT SEPARATE SQUIB CABLE WITH SAFETY CAP FROM SQUIB. Failure to follow precautions can result in injury to personnel.

4. If squib **(1)** is not installed in EPJD, without removing squib cable **(20)** and safety cap **(10)**, thread squib into housing **(2)**.
5. Apply a light coating of O-ring lube to a new preformed packing for squib.

**WARNING**

After the squib has been installed in the EPJD, handle EPJD from the bottom only. Failure to do so can result in injury to personnel.

6. If storing EPJD with squib installed, install EPJD and squib cable **(20)** in cover. Ensure velcro closures are on the bottom of the EPJD.

**REPLACE**

1. Replace squib cable helical wrap.
  - a. Carefully remove damaged wrap from cable.
  - b. Inspect cable for damage IAW WP 0005 00. If cable is in good working condition continue to step c., below. If cable is unserviceable, replace with a serviceable item from stock.
  - c. Cut suitable length of helical wrap.
  - d. Open one end of wrap and rewrap cable ensuring helical wrap covers entire length of squib cable.
2. If cable is unserviceable, replace squib cable with a serviceable item from stock.

**END OF WORK PACKAGE**



---

**UNIT MAINTENANCE**  
**ANCILLARY EQUIPMENT FOR LOW VELOCITY AIR DROP SYSTEMS (LVADS)**  
**Y-CONNECTOR**

---

**THIS TASK COVERS:**

- Inspect
  - Test
  - Repair
  - Replace
- 

**Tools**

Power Supply, 28 VDC (Item 25, WP 0064 00)  
Simulator, Initiator (Item 43, WP 0064 00)

**Materials/Parts**

Box, Control (Item 1, WP 0104 00)  
Cable, Power, 20-Foot (Item 1, WP 0110 00)  
LED (Item 16/17, WP 0125 00)  
Y-Connector (Item 1, WP 0101 00)

**Personnel Required**

92R (10) Parachute Rigger

**Equipment Condition**

Separated from the Y-connector mounting box.

**References**

WP 0005 00; WP 0007 00

---

**INSPECT**

Inspect the Y-connector in accordance with WP 0007 00 and WP 0005 00, Table 1.

**TEST**

Test the LED.

1. Ensure the POWER and JETTISON switches of a serviceable control box are both OFF. Connect J1 of the Y-connector to J2 of the control box. Connect the P1 plug of a serviceable power cable to the J1 receptacle of the control box.
2. Connect the P2 plug of the power cable to the 27 VDC power supply.
3. Plug the 28 VDC power supply cord into the 115 VAC power source.
4. Turn the power supply ON. Ensure the control box circuit breaker is pushed in. Set the POWER switch of the control box to the ON position.
5. Rotate the DIMMER adjust knob on the control box fully clockwise.
6. Press the LAMP TEST switch on the Y-connector. If the LED does not light, set the control box POWER switch to the OFF position and replace LED. If the LED does light, set the control box POWER switch to the OFF position and continue with steps 7 through 9.
7. Ensure the circuit breaker switches of the initiator simulator are in the ON position. Connect the J1 connector (quick disconnect) of the initiator simulator to the J3 receptacle of the Y-connector.
8. Set the control box POWER switch to the ON position and activate the JETTISON SWITCH on the control box. The circuit breaker switches should trip to the OFF position. If they do not, replace the Y-connector. If they do, return Y-connector to service.
9. Turn 28 VDC power supply OFF and disconnect from 115 VAC power source. Disconnect initiator simulator from Y-connector; disconnect Y-connector from control box; disconnect 20-foot power cable from control box and 28 VDC power supply.
10. Return pieces and parts to proper storage location.

**REPAIR**

Repair Defective LED.

1. Remove the four thumbscrews, the five pan head screws, and the cover of the Y-connector.
2. Remove and discard the defective LED from its socket.

**CAUTION**

Make sure that the flat on the flange of the LED lines up with the flat that is marked on the socket. Improper installation may damage LED.

3. Install the new LED so the flat base of the LED matches the flat of the circle on the circuit board.
4. Reinstall the cover, pan head screws, and thumbscrews.
5. Ensure the circuit breaker switches of the initiator simulator are in the ON position. Connect the J1 connector (quick disconnect) of the initiator simulator to the J3 receptacle of the Y-connector.
6. Set the control box POWER switch to the ON position and activate the JETTISON SWITCH on the control box. The circuit breaker switches should trip to the OFF position. If they do not, replace the Y-connector. If they do, return Y-connector to service.
7. Turn 28 VDC power supply OFF and disconnect from 115 VAC power source. Disconnect initiator simulator from Y-connector; disconnect Y-connector from control box; disconnect 20-foot power cable from control box and 28 VDC power supply.
8. Return pieces and parts to proper storage location.

**REPLACE**

Replace an unserviceable Y-connector with a serviceable item from stock.

**END OF WORK PACKAGE**

**UNIT MAINTENANCE  
 ANCILLARY EQUIPMENT FOR LOW VELOCITY AIR DROP SYSTEMS (LVADS)  
 Y-CONNECTOR MOUNTING BOX (C-130, C-141, C-17, C-5)**

**THIS TASK COVERS:**

- Inspect
- Replace

**Tools**  
 None

**Personnel Required**  
 92R (10) Parachute Rigger

**Materials/Parts**  
 None

**Equipment Condition**  
 N/A

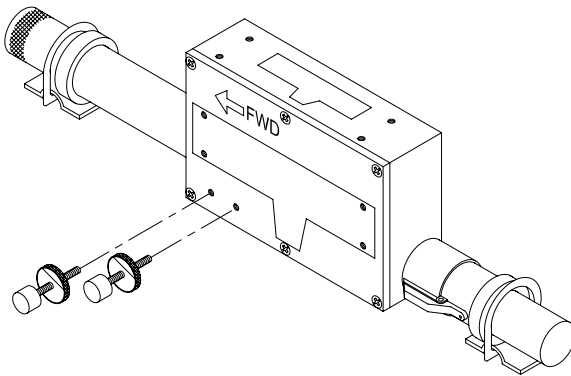
**References**  
 WP 0005 00; WP 0007 00

**INSPECT**

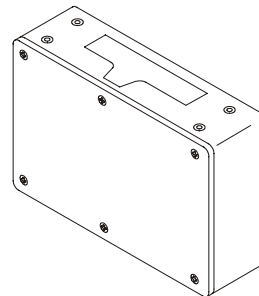
Inspect the Y-connector mounting box in accordance with WP 0007 00 and WP 0005 00, Table 1.

**REPLACE**

Replace an unserviceable Y-connector mounting box with a serviceable item from stock.



**(C-130, C-141, C-17)**



**(C-5)**

**END OF WORK PACKAGE**



---

**UNIT MAINTENANCE  
ANCILLARY EQUIPMENT FOR LOW VELOCITY AIR DROP SYSTEMS (LVADS)  
CONTROL BOX**

---

**THIS TASK COVERS:**

- Inspect
  - Test
  - Repair
  - Replace
- 

**Tools**

Nut Driver,  $\frac{3}{16}$  -IN. (Item 22, WP 0064 00)  
Power Supply, 28 VDC (Item 25, WP 0064 00)  
Screwdriver, Cross-Tip, No. 1 (Item 27, WP 0064 00)

**Materials/Parts**

Cable, Power, 20-Foot (Item 1, WP 0110 00)  
LED (Item 16/17, WP 0125 00)

**Personnel Required**

92R (10) Parachute Rigger

**Equipment Condition**

Removed from system.  
POWER switch in OFF position.  
JETTISON SWITCH in OFF position.

**References**

WP 0005 00; WP 0007 00

---

**INSPECT**

Inspect the control box in accordance with WP007 00 AND WP005 00 and Table 1.

**TEST**

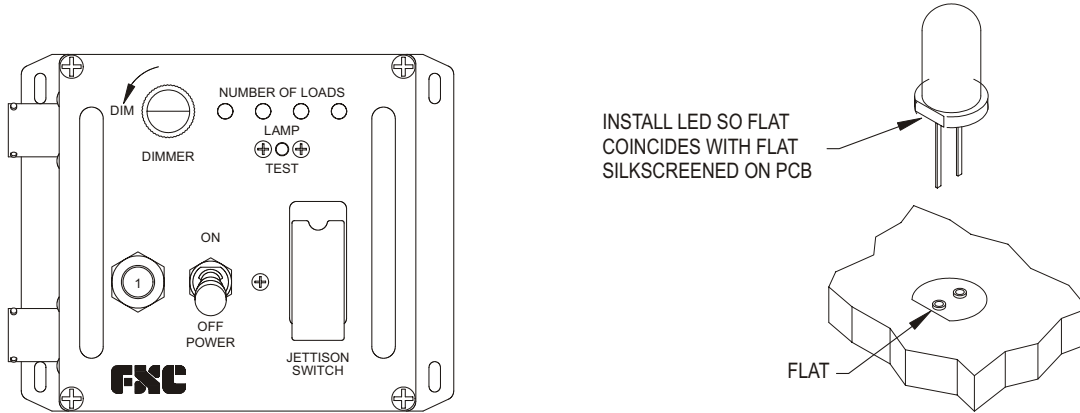
Test the LED(s).

1. Connect the P1 plug of a serviceable power cable to the J1 receptacle of the control box.
2. Connect the P2 plug of the power cable to the 28 VDC power supply.
3. Plug 28 VDC power supply cord into 115 VAC power source.
4. Turn the power supply ON. Ensure that the control box circuit breaker is pushed in.
5. Set the POWER switch of the control box to the ON position.
6. Rotate the DIMMER adjust knob on the control box fully clockwise.
7. Press the LAMP TEST switch on the control box.
8. If all four LEDs light up, return control box to service. If all four LEDs do not light up, set POWER switch of control box to OFF and replace 20-foot power cable.
9. Repeat steps 4 through 6.
10. If one or more LEDs do not light, replace defective LED(s).

**REPAIR**

Repair Defective LED(s).

1. Set the POWER switch on the control box and 28 VDC power supply to OFF. Disconnect power cable from the control box.
2. Remove the four screws and the cover of the control box.
3. On the backside of the cover, using nut driver, remove the two nuts holding the printed circuit board (PCB) to the cover. Carefully remove the PCB from the cover.
4. Remove and discard the defective LED(s) from its socket.



**CAUTION**

Make sure that the flat on the flange of the LED lines up with the flat that is marked on the PCB. Improper installation may damage the LED.

5. Install the new LED(s) so the flat side of the LED base matches the flat side of circle on PCB.
6. Reinstall the PCB to the cover using the two (2) nuts.
7. Reinstall the cover of the control box using the four (4) screws.
8. Repeat the inspection procedure to ensure all LEDs light up.

**REPLACE**

Replace an unserviceable control box with a serviceable item from stock.

**END OF WORK PACKAGE**



---

**UNIT MAINTENANCE**  
**ANCILLARY EQUIPMENT FOR LOW VELOCITY AIR DROP SYSTEMS (LVADS)**  
**PLATFORM CABLE (ALL)/ 4-FOOT EXTENSION CABLE (C-5 and C-17 only)**

---

**THIS TASK COVERS:**

- Inspect
  - Test
  - Replace
- 

**Tools**

Power Supply, 28 VDC (Item 27, WP 0064 00)  
Simulator, Initiator (Item 43, WP 0064 00)

**Materials/Parts**

Box, Control (Item 1, WP 0104 00)  
Cable, Interconnect, 10-Foot (Item 1, WP 0108 00)  
Cable, Platform, 10-Foot (Item 1, WP 0107 00)  
Cable, Power, 20-Foot (Item 1, WP 0110 00)  
Y-Connector (Item 1, WP 0101 00)

**Personnel Required**

92R (10) Parachute Rigger

**Equipment Condition**

N/A

**References**

WP 0005 00; WP 0007 00

---

**INSPECT**

Inspect all platform cables and the 4-foot interconnect cables in accordance with WP 0007 00 and WP 0005 00, Table 1.

**TEST**

Test cable continuity.

1. Ensure the POWER and JETTISON switches of a serviceable control box are both OFF.
2. Connect the P13 connector of the 4-foot extension cable to the J3 connector of a serviceable Y-connector.
3. Connect the P1 plug of a serviceable interconnect cable to the J1 receptacle of a serviceable Y-connector.
4. Connect the P2 plug of the interconnect cable to the J2 receptacle of a serviceable control box.
5. Connect the P1 plug of a serviceable power cable to the J2 receptacle of the control box.
6. Connect the P2 plug of the power cable to the 28 VDC power supply.
7. Plug 28 VDC power supply cord into 115 VAC power source.
8. Connect the J1 receptacle of a serviceable initiator simulator to the J13 connector of the 4-foot extension cable. Make sure the two circuit breakers on the initiator simulator are set to ON.
9. Turn the power supply ON. Ensure the control box circuit breaker is pushed in.
10. Set POWER switch of the control box to ON.
11. Rotate the DIMMER adjust knob on the control box fully clockwise.
12. Check that one LED on the control box is lit, and the LED on the Y-connector is lit.

13. Lift the guard of the JETTISON SWITCH and place the JETTISON SWITCH in the ON position.
14. Turn 28 VDC power supply OFF and disconnect from 115 VAC power source. Disconnect 20-foot power cable from 28 VDC power supply and control box.
15. Return pieces and parts to proper storage location.

**REPLACE**

Replace an unserviceable platform cable or 4-foot extension cable with a serviceable item from stock.

**END OF WORK PACKAGE**

---

**UNIT MAINTENANCE**  
**ANCILLARY EQUIPMENT FOR LOW VELOCITY AIR DROP SYSTEMS (LVADS)**  
**10-FOOT INTERCONNECT CABLE**

---

**THIS TASK COVERS:**

- Inspect
  - Test
  - Replace
- 

**Tools**

Power Supply, 28 VDC (Item 27, WP 0064 00)

**Materials/Parts**

Box, Control (Item 1, WP 0104 00)  
Cable, Power, 20-Foot (Item 1, WP 0110 00)  
Y-Connector (Item 1, WP 0101 00)

**Personnel Required**

92R (10) Parachute Rigger

**Equipment Condition**

N/A

**References**

WP 0005 00; WP 0007 00

---

**INSPECT**

Inspect the 10-foot interconnect cable in accordance with WP 0007 00 and WP 0005 00, Table 1.

**TEST**

Test cable continuity.

1. Ensure the POWER and JETTISON switches of a serviceable control box are both OFF.
2. Connect the P1 plug of the 10-foot interconnect cable to the J1 receptacle of a serviceable Y-connector.
3. Connect the P2 plug of the 10-foot interconnect cable to the J2 receptacle of a serviceable control box.
4. Connect the P1 plug of a serviceable power cable to the J1 receptacle of the control box.
5. Connect the P2 plug of the power cable to the 28 VDC power supply.
6. Plug 28 VDC power supply cord into 115 VAC power source.
7. Turn the power supply ON. Ensure the control box circuit breaker is pushed in. Set the POWER switch of the control box to the ON position.
8. Rotate the DIMMER adjust knob on the control box fully clockwise.
9. Press the LAMP TEST switch on the Y-connector. If the LED(s) light up, the 10-foot interconnect cable is serviceable. If the LED(s) do not light, replace the 10-foot interconnect cable.
10. Turn 28 VDC power supply OFF and disconnect from 115 VAC power source. Disconnect 10-foot power cable from 28 VDC power supply and control box.
11. Return pieces and parts to proper storage location.

**REPLACE**

Replace an unserviceable 10-foot interconnect cable with a serviceable item from stock.

**END OF WORK PACKAGE**



---

**UNIT MAINTENANCE  
ANCILLARY EQUIPMENT FOR LOW VELOCITY AIR DROP SYSTEMS (LVADS)  
50-FOOT MAIN CABLE**

---

**THIS TASK COVERS:**

- Inspect
  - Test
  - Replace
- 

**Tools**

Power Supply, 28 VDC (Item 27, WP 0064 00)

**Materials/Parts**

Box, Control (Item 1, WP 0104 00)  
Cable, Power, 20-Foot (Item 1, WP 0110 00)  
Y-Connector (Item 1, WP 0101 00)

---

**Personnel Required**

92R (10) Parachute Rigger

**References**

WP 0005 00; WP 0007 00

---

**INSPECT**

Inspect the 50-foot main cable in accordance with WP 0007 00 and WP 0005 00, Table 1.

**TEST**

Test cable continuity.

1. Ensure the POWER and JETTISON switches of a serviceable control box are both OFF.
2. Connect the P1 plug of the main cable to the J1 receptacle of a serviceable Y-connector.
3. Connect the P2 plug of the main cable to the J2 receptacle of a serviceable control box.
4. Connect the P1 plug of a serviceable power cable to the J1 receptacle of the control box.
5. Connect the P2 plug of the power cable to the 28 VDC power supply.
6. Plug 28 VDC power supply cord into the 115 VAC power source.
7. Turn the power supply ON. Ensure the control box circuit breaker is pushed in. Set the POWER switch of the control box to the ON position.
8. Rotate the DIMMER adjust knob on the control box fully clockwise.
9. Press the LAMP TEST switch on the Y-connector. If the LED(s) do light up, the 50-foot main cable is serviceable. If the LED(s) do not light up, replace the 50-foot main cable.
10. Turn 28 VDC power supply OFF and disconnect from 115 VAC power source. Disconnect 20-foot power cable from 28 VDC power supply and control box.
11. Return pieces and parts to proper storage location.

**REPLACE**

Replace an unserviceable 50-foot main cable with a serviceable item from stock.

**END OF WORK PACKAGE**

**0050 00-1/(2 Blank)**



---

**UNIT MAINTENANCE**  
**ANCILLARY EQUIPMENT FOR LOW VELOCITY AIR DROP SYSTEMS (LVADS)**  
**20-FOOT POWER CABLE**

---

**THIS TASK COVERS:**

- Inspect
  - Test
  - Replace
- 

**Tools**

Power Supply, 28 VDC (Item 27, WP 0064 00)

**Personnel Required**

92R (10) Parachute Rigger

**Materials/Parts**

Box, Control (Item 1, WP 0104 00)

**References**WP 0005 00; WP 0007 00

---

**INSPECT**

Inspect the 20-foot power cable in accordance with WP 0007 00 and WP 0005 00, Table 1.

**TEST**

Test cable continuity.

1. Ensure the POWER and JETTISON switches of a serviceable control box are both OFF. Connect the P1 plug of the cable to the J1 receptacle of the control box.
2. Connect the P2 plug of the power cable to the 28 VDC power supply.
3. Plug the 28 VDC power supply cord into the 115 VAC power source.
4. Turn the power supply ON. Ensure that the control box circuit breaker is pushed in. Set the power switch of the control box to the ON position.
5. Rotate the DIMMER adjust knob on the control box fully clockwise.
6. Press the LAMP TEST switch on the control box. If the LED(s) do light up, the 20-foot cable is serviceable.
7. If the LED(s) do not light up, replace the 20-foot power cable.
8. Turn 28 VDC power supply OFF and disconnect from 115 VAC power source. Disconnect 20-foot power cable from 28 VDC power supply and control box.
9. Return pieces and parts to proper storage location.

**REPLACE**

Replace an unserviceable 20-foot power cable with a serviceable item from stock.

**END OF WORK PACKAGE**





---

**UNIT MAINTENANCE  
ANCILLARY EQUIPMENT FOR LOW VELOCITY AIR DROP SYSTEMS (LVADS)  
PROTECTIVE COVER**

---

**THIS TASK COVERS:**

- Inspect
  - Repair
  - Replace
- 

**Tools**

Die, Grommet Setting (Item 7, WP 0064 00)  
Grommet, Metallic, Spur, Die Set (Item 12, WP 0064 00)  
Mallet, Rawhide (Item 21, WP 0064 00)  
Set, Chuck and Die (Item 31, WP 0064 00)  
Sewing Machine, Darning (Item 32/33, WP 0064 00)  
Sewing Machine, General Sewing (Item 35, WP 0064 00)

**Materials/Parts**

Fastener Tape, Hook, Synthetic, 1 ½-IN. (Item 11, WP 0125 00)  
Fastener Tape, Pile, Synthetic, ¾-IN. (Item 12, WP 0125 00)  
Thread, Nylon, Size E, OD (Item 32, WP 0125 00)

**Personnel Required**

92R (10) Parachute Rigger

**Equipment Condition**

Cover removed from system.  
Unpacked. Canopy with defects recorded. Clean.

**References**

WP 0005 00; WP 0007 00

---

**INSPECT**

Perform a technical/rigger type inspection of the cover in accordance with WP 0007 00 and WP 0005 00, Table 1.

**REPAIR**

---

**NOTE**

---

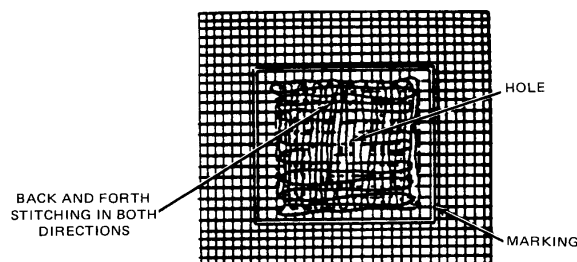
Sewing requirements will vary according to the type of item being repaired and the type of repair being made. The type of sewing machine, type of thread, the stitch range, and the stitch pattern (if applicable) required to accomplish a sewing procedure will be specified in the paragraph applicable to the item being repaired. All original stitching that is cut during the performance of a sewing procedure will be removed from the applicable item. Immediately after the accomplishment of a machine sewing procedure, trim thread ends to a point as close as possible to the material that has been sewn.

Table 2-3. Sewing Machine Code Symbols.

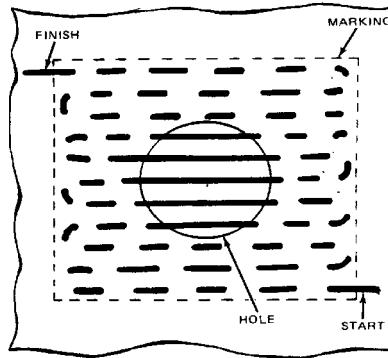
Code Symbol	Sewing Machine
LD	SEWING MACHINE, INDUSTRIAL: General Sewing; 301 Stitch; Light Duty; NSN 3530-01-177-8590.
MD ZZ	SEWING MACHINE, INDUSTRIAL: Zigzag; 308 Stitch; Medium-Duty; NSN 3530-01-181-1421.
LD ZZ	SEWING MACHINE, INDUSTRIAL: Zigzag; 308 Stitch; Light Duty; NSN 3530-01-181-1420.
HD	SEWING MACHINE, INDUSTRIAL: General Sewing; 301 Stitch; Heavy-Duty; NSN 3530-01-177-8588.
MD	SEWING MACHINE, INDUSTRIAL: General Sewing; 301 Stitch; Medium-Duty; NSN 3530-01-177-8591.
DN	SEWING MACHINE, INDUSTRIAL: Darning; Lock Stitch; NSN 3530-01-177-8589.
LHD	SEWING MACHINE, INDUSTRIAL: 301 Stitch; Light Heavy-Duty; NSN 3530-01-186-3079.
ND	SEWING MACHINE, INDUSTRIAL: 301 Stitch; Double Needle; NSN 3530-01-182-2873.
BT	SEWING MACHINE, INDUSTRIAL: Bartack (Local Purchase)

**Darning Repair.** Darning is a sewing procedure used to repair limited size holes, rips, and tears. A darning repair may be made either by hand or by sewing machine, depending upon the method preferred and the availability of equipment. However, a darning machine should be used to darn small holes and tears where fabric is missing. A darning repair will be performed using the following procedures, as appropriate:

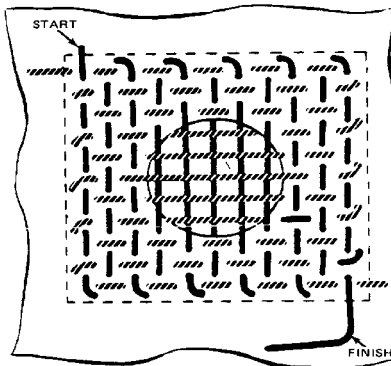
1. Machine darning. Proceed as follows:
  - a. Using an authorized marking aid of contrasting color, mark a square around the damaged area and ensure the marking is at least 1/4-inch back from each edge of the damaged area.
  - b. Darn the damaged area by sewing the material in a back and forth manner, using size A or E nylon thread.
  - c. Turn the material and stitch back and forth across the stitching made in b., above, until the hole or tears are completely darned.



2. Hand darning. When repair of a hole or tear is made by hand darning, the darn should match the original weave of the damaged material as closely as possible. Hand darning will be performed as follows:
  - a. Using an authorized marking aid of contrasting color, mark a square around the damaged area and ensure the marking is at least  $\frac{1}{4}$ -inch back from each edge of the damaged area.
  - b. Using a darning needle and a length of size A or E nylon thread, begin darning at one corner of the marked area. Working parallel with the marking, pass the needle and thread back and forth through the material until the opposite diagonal corner of the marked area is reached.



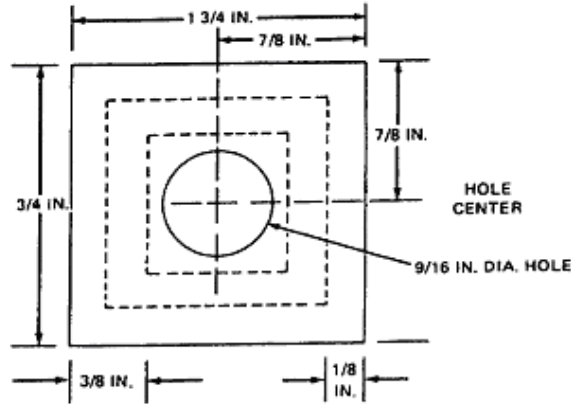
- c. Turn the material and weave the needle and thread back and forth across the stitching made in b., above, until the hole is completely darned.



### Grommet Repair.

1. Repair grommet as follows:
  - a. Remove burns, rough spots, rust, or corrosion from an installed grommet by filing with a file or by buffing with a crocus cloth.
  - b. Reseat a loose grommet using the procedures listed in step 2., following.

- c. If fabric area around original grommet has been damaged, repair area by darning using procedures in darning procedural steps detailed above. If darning does not provide an adequate repair, construct a 2 3/4- by 2 3/4-inch sized reinforcement cloth and fold under 1/2-inch on all sides. After removing original grommet, sew cloth to inside with a medium-duty sewing machine, size E nylon thread, 7 to 11 stitches per inch, one row of stitches 1/8-inch from inside edge and the second row 3/8-inch from outside edge.

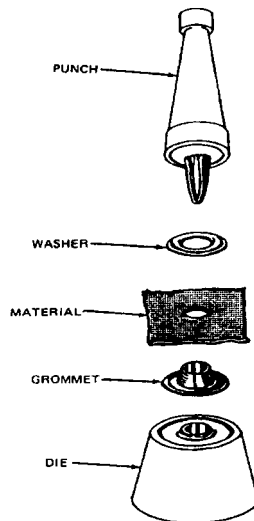


- 2. Replace grommet as follows:

**NOTE**

For grommet installation by the hand-held method, refer to steps c. through f., following. For grommet installation by hand-or foot-operated press, refer to steps g. through k.

- a. Using a suitable type tool, lift edge of original washer at one point.
- b. Grip lifted washer edge with lineman pliers and roll washer edge back to lift washer from original grommet. Remove original grommet from material.
- c. Insert barrel of replacement grommet through accommodating hole in material and ensure grommet flange is located on same side of material as original grommet.

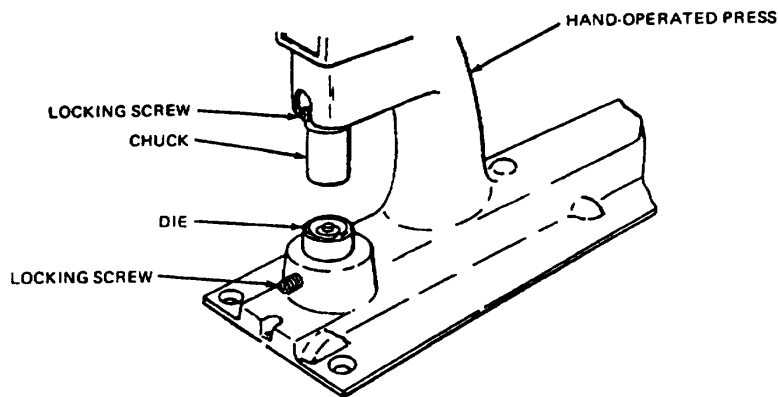


- d. Position grommet on die with barrel facing up, position material over grommet barrel, and place the washer over grommet barrel.

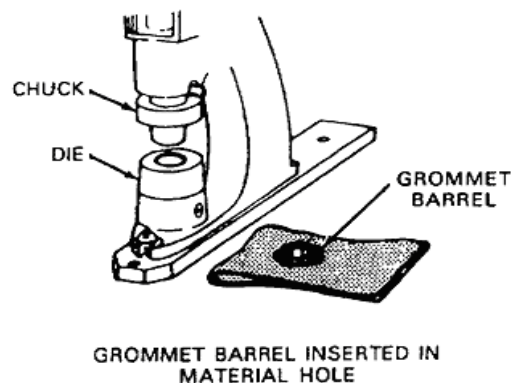
**NOTE**

When installing a flat grommet by the hand-held method, ensure the grommet barrel and washer are aligned to preclude off-center setting of the grommet.

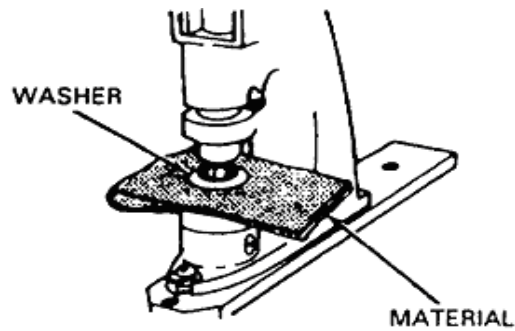
- e. Using a punch and rawhide mallet or other non-steel impact device, spread grommet barrel by hammering until barrel collar is rolled down smooth on washer. If grommet barrel splits during hammering process, remove and replace damaged grommet with a serviceable item from stock, repeating procedures in step d. and e., above.
- f. Check seating of grommet. If grommet can be turned by hand, repeat step e. until grommet is firmly seated.
- g. Install appropriate chuck or die in hand-operated press and secure locking screws with hex wrench or screwdriver.



- h. Insert barrel of replacement grommet through hole in material. Ensure grommet flange is on same side of material as original grommet (grommet barrel inserted in material hole).

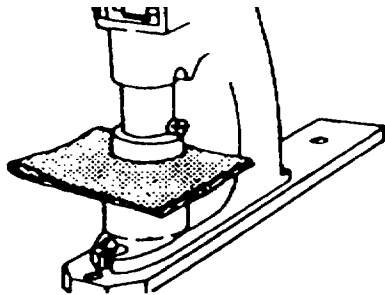


- i. Position grommet on die in press with barrel facing up and place replacement washer over barrel (washer placed over grommet barrel).

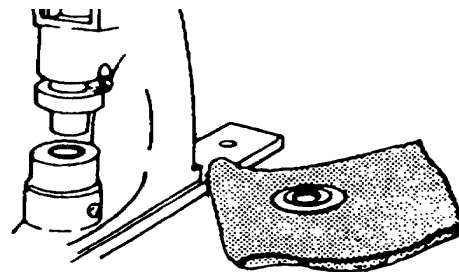


WASHER PLACED OVER GROMMET BARREL

- j. Depress handle or foot pedal, spreading grommet barrel until collar is rolled down smoothly on washer (press activated to seat the grommet).



PRESS ACTIVATED TO SEAT THE GROMMET



GROMMET INSTALLATION COMPLETED

- k. Check grommet for firm seating. If grommet can be turned by hand, repeat step j., above, until a firm seat is achieved (grommet installation completed).

**REPLACE**

Replace an unserviceable item with a serviceable item from stock.

**END OF WORK PACKAGE**

---

**UNIT MAINTENANCE  
ANCILLARY EQUIPMENT FOR LOW VELOCITY AIR DROP SYSTEMS (LVADS)  
KIT BAG**

---

**THIS TASK COVERS:**

- Inspect
  - Repair
  - Replace
- 

**Tools**

Sewing Machine, Darning (Item 32/33, WP 0064 00)  
Sewing Machine, Medium Duty (Item 35, WP 0064 00)

**Materials/Parts**

Thread, Nylon, Size E, OD (Item 32, WP 0125 00)

**Personnel Required**

92R (10) Parachute Rigger

**Equipment Condition**

N/A

**References**

WP 0005 00; WP 0007 00;  
WP 0010 00

---

**INSPECT**

Perform a technical/rigger type inspection of the cover in accordance with WP 0007 00 and WP 0005 00, Table 1.

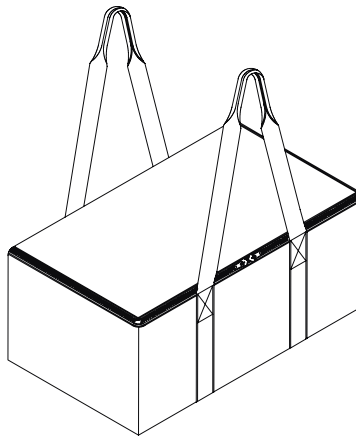
**REPAIR**

Darning Rips, Holes, and Tears.

1. Refer to darning procedures in WP 0010 00.
2. Repair damaged seams using a medium-duty sewing machine, in accordance with original construction, using size E nylon thread and 7 to 11 stitches per inch.

**REPLACE**

Replace an unserviceable item with a serviceable item from stock.



**END OF WORK PACKAGE**





---

**UNIT MAINTENANCE**  
**ANCILLARY EQUIPMENT FOR LOW VELOCITY AIR DROP SYSTEMS (LVADS)**  
**Y-CONNECTOR MOUNTING BOX TIE-DOWN BRACKET (C-5)**

---

**THIS TASK COVERS:**

- Inspect
  - Replace
- 

**Tools**

N/A

**Materials/Parts**

N/A

**Personnel Required**

92R (10) Parachute Rigger

**Equipment Condition**

N/A

**References**

WP 0005 00; WP 0007 00

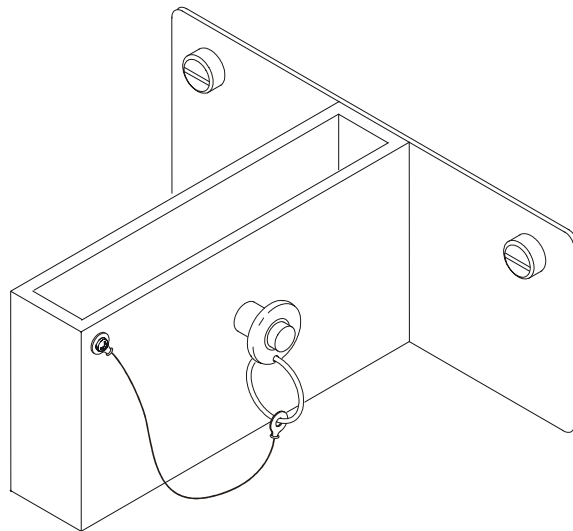
---

**INSPECT**

Inspect the tie-down bracket in accordance with WP 0007 00 and WP 0005 00, Table 1.

**REPLACE**

Replace an unserviceable tie-down bracket (C-5 only) with a serviceable item from stock.



**END OF WORK PACKAGE**



---

**UNIT MAINTENANCE**  
**ANCILLARY EQUIPMENT FOR LOW VELOCITY AIR DROP SYSTEMS (LVADS)**  
**20-FOOT POWER CABLE EXTENSION (C-17 only)**

---

**THIS TASK COVERS:**

- Inspect
  - Replace
- 

**Tools**

N/A

**Materials/Parts**

N/A

**Personnel Required**

92R (10) Parachute Rigger

**Equipment Condition**

N/A

**References**

WP 0005 00; WP 0007 00

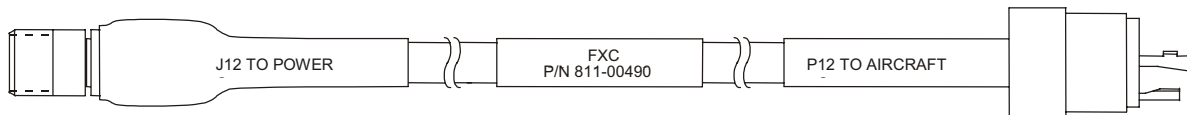
---

**INSPECT**

Inspect the 20-foot power cable extension in accordance with WP 0007 00 and WP 0005 00, Table 1.

**REPLACE**

Replace an unserviceable 20-foot power cable extension (C-17 only) with a serviceable item from stock.



**END OF WORK PACKAGE**



---

**UNIT MAINTENANCE**  
**ANCILLARY EQUIPMENT FOR LOW VELOCITY AIR DROP SYSTEMS (LVADS)**  
**1-FOOT POWER CABLE ADAPTER (C-5 only)**

---

**THIS TASK COVERS:**

- Inspect
  - Replace
- 

**Tools**

N/A

**Personnel Required**

92R (10) Parachute Rigger

**Materials/Parts**

1-Foot Power Cable Adapter (Item 1, WP 0116 00)

**Equipment Condition**

N/A

**References**

WP 0005 00; WP 0007 00

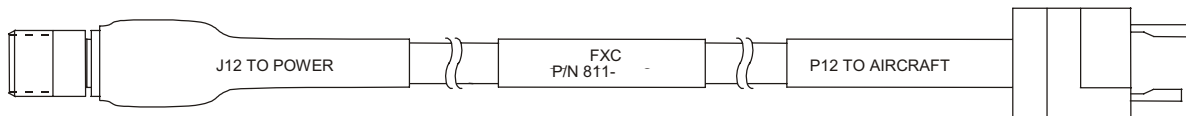
---

**INSPECT**

Inspect the power cable adapter in accordance with WP 0007 00 and WP 0005 00, Table 1.

**REPLACE**

Replace an unserviceable power cable adapter (C-5 only) with a serviceable item from stock.



**END OF WORK PACKAGE**



---

**UNIT MAINTENANCE**  
**ANCILLARY EQUIPMENT FOR LOW VELOCITY AIR DROP SYSTEMS (LVADS)**  
**SAFETY CAP**

---

**THIS TASK COVERS:**

- Inspect
  - Replace
- 

**Tools**

N/A

**Personnel Required**

92R (10) Parachute Rigger

**Materials/Parts**

Safety Cap (Item 1, WP 0117 00)

**Equipment Condition**

N/A

**References**

WP 0005 00; WP 0007 00

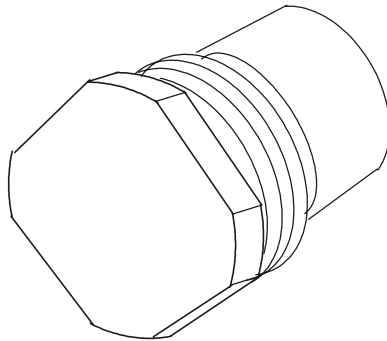
---

**INSPECT**

Inspect the safety cap in accordance with WP 0007 00 and WP 0005 00, Table 1.

**REPLACE**

Replace an unserviceable safety cap with a serviceable item from stock.



**END OF WORK PACKAGE**





---

**UNIT MAINTENANCE  
ANCILLARY EQUIPMENT FOR LOW VELOCITY AIR DROP SYSTEMS (LVADS)  
INITIATOR SIMULATOR**

---

**THIS TASK COVERS:**

- Inspect
  - Test
  - Replace
- 

**Tools**

Power Supply, 28 VDC (Item 25, WP 0064 00)

**Materials/Parts**

Y-Connector (Item 1, WP 0101 00)  
Box, Control (Item 1, WP 0104 00)  
Cable, Power, 20-Foot (Item 1, WP 0110 00)

**Personnel Required**

92R (10) Parachute Rigger

**Equipment Condition**

N/A

**References**

WP 0005 00; WP 0007 00

---

**INSPECT**

Perform a technical/rigger type inspection of the initiator simulator in accordance with WP 0007 00 and WP 0005 00, Table 1.

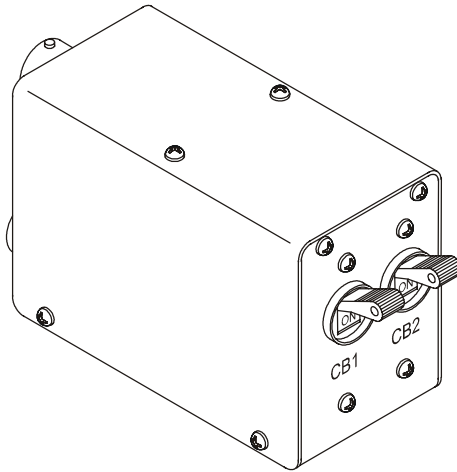
**TEST**

Testing the initiator simulator.

1. Ensure the POWER and JETTISON switches of a serviceable control box are OFF. Connect P1 plug of a serviceable 20-foot power cable to J1 receptacle of control box.
2. Connect the P2 plug of the power cable to the 28 VDC power supply.
3. Plug the 28 VDC power supply cord into the 115 VAC power source.
4. Turn the power supply ON. Ensure the control box circuit breaker is pushed in.
5. Connect J1 receptacle of initiator simulator directly into J3 receptacle of a serviceable Y-connector.
6. Connect J1 receptacle of Y-connector directly into J2 receptacle of control box.
7. Set circuit breakers on initiator simulator to ON.
8. Set POWER switch of control box to ON.
9. Set JETTISON SWITCH on control box to ON. If both circuit breakers on the initiator simulator are tripped to OFF, the initiator simulator is serviceable. If either one or both breakers do not trip, the initiator simulator is defective.

**REPLACE**

Replace an unserviceable initiator simulator with a serviceable item from stock.



**END OF WORK PACKAGE**

---

**UNIT MAINTENANCE**  
**ANCILLARY EQUIPMENT FOR LOW VELOCITY AIR DROP SYSTEMS (LVADS)**  
**SQUIB TESTER**

---

**THIS TASK COVERS:**

- Inspect
  - Test
  - Repair
  - Replace
- 

**Tools**

Power Supply, 28 VDC (Item 25, WP 0064 00)  
Screwdriver, Cross-Tip, No. 1 (Item 27, WP 0064 00)

**Materials/Parts**

Battery, AAA, 2 ea. (Item 2, WP 0125 00)  
LED, Red (Item 17, WP 0125 00)  
Wire, 20-gauge (Item 39, WP 0125 00)

---

**Personnel Required**

92R (10) Parachute Rigger

**References**

WP 0005 00; WP 0007 00

---

**INSPECT**

Perform a technical/rigger type inspection of the squib tester in accordance with WP 0007 00 and WP 0005 00, Table 1.

**TEST**

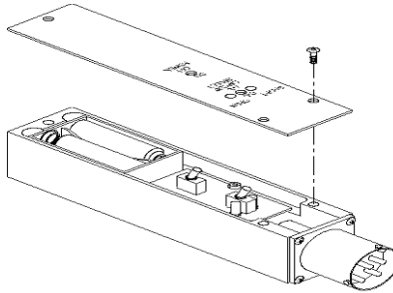
Testing batteries and LED.

1. Set CIRCUIT SELECT switch to A-B.
2. Set POWER switch to ON. OPEN LED should illuminate. If OPEN LED does not illuminate, skip to REPAIR procedures.
3. Set CIRCUIT SELECT switch to C-D. OPEN LED should illuminate. Replace squib tester if OPEN LED does not illuminate.
4. Using a suitable length of 20-gauge or smaller wire (paperclip is equivalent), connect receptacle pins C and D. SHORT LED should illuminate. If SHORT LED does not illuminate, skip to REPAIR procedure step 6.
5. Remove wire from pins C and D and connect receptacle pins A and B.
6. Set CIRCUIT SELECT to A-B. SHORT LED should illuminate. If SHORT LED does not illuminate, replace squib tester.
7. If LEDs illuminate properly, remove wire, turn POWER switch to OFF, and return squib tester to service.

**REPAIR**

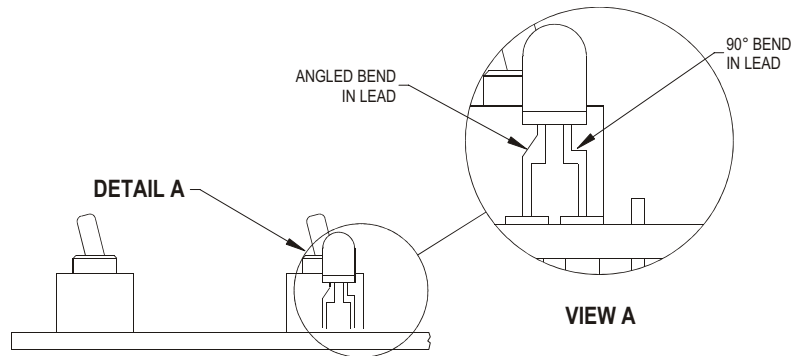
Replacing batteries and LEDs.

1. Remove three pan-head screws and cover from squib tester.

**NOTE**

When replacing batteries, always replace both batteries.

2. Replace batteries; make sure to orient battery (+) and (-) terminals as shown in battery holder.
3. Set POWER switch to ON. If OPEN LED illuminates, test is complete.
4. Replace LED D1. Orient LED as shown in following illustration.



5. If OPEN LED illuminates, proceed with WP 0047 00, CONTROL BOX. If OPEN LED does not illuminate, replace squib tester.
6. Replace LED D2. Orient LED as shown in previous illustration.
7. Verify receptacle pins C and D are connected. CIRCUIT SELECT switch is set to C-D and POWER switch is ON. SHORT LED should illuminate. If SHORT LED illuminates, proceed with WP 0047 00, CONTROL BOX. If SHORT LED does not illuminate, verify correct installation. If short LED still does not illuminate, replace squib tester.
8. Remove wire connecting receptacle pins A and B. Replace cover and three pan-head screws and return squib tester to service.

**END OF WORK PACKAGE**

---

**UNIT MAINTENANCE  
ANCILLARY EQUIPMENT FOR LOW VELOCITY AIR DROP SYSTEMS (LVADS)  
28 VDC POWER SUPPLY**

---

**THIS TASK COVERS:**

- Inspect
  - Replace
- 

**Tools**

None

**Personnel Required**

92R (10) Parachute Rigger

**Materials/Parts**

Power Supply, 28 VDC (Item 1, WP 0120 00)

**References**

WP 0005 00; WP 0007 00

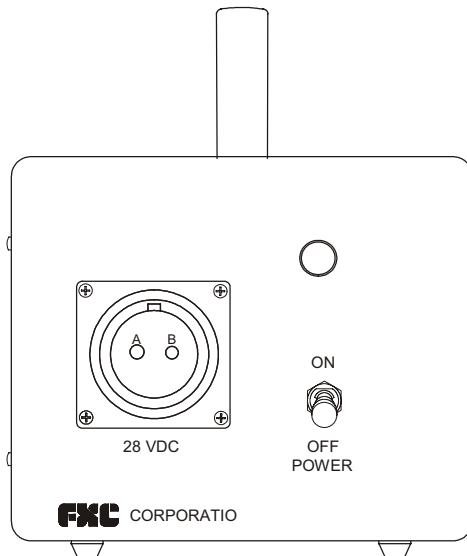
---

**INSPECT**

Perform a technical/rigger type inspection of the 28 VDC Power Supply in accordance with WP 0007 00 and WP 0005 00, Table 1.

**REPLACE**

Replace an unserviceable 28 VDC Power Supply with a serviceable item from stock.



**END OF WORK PACKAGE**



**CHAPTER 4**  
**SUPPORTING INFORMATION**  
**FOR**  
**ANCILLARY EQUIPMENT FOR**  
**LOW VELOCITY AIR DROP SYSTEMS (LVADS)**





---

**SUPPORTING INFORMATION**  
**ANCILLARY EQUIPMENT FOR LOW VELOCITY AIR DROP SYSTEMS (LVADS)**  
**PREPARATION FOR STORAGE**

---

**PREPARATION FOR STORAGE**

Prepare the LVADS ancillary equipment for shipment by packing components into original or similar containers in which they were received.

**ADMINISTRATIVE STORAGE**

Placement of LVADS ancillary equipment in administrative storage should be for brief periods when a maintenance resource shortage exists. Items should be in mission readiness within 24-hours or within the time factors as determined by the directing authority. During the short period, appropriate maintenance records will be kept.

Before placing the equipment in administrative storage, complete current preventive maintenance checks and services, correct shortcomings, deficiencies, and apply applicable Modification Work Orders (MWO).

**Storage Site Selection.** To maintain the serviceability of stored LVADS Ancillary Equipment, use the following procedures:

1. When available, store the LVADS ancillary equipment in a heated building.
2. LVADS Ancillary Equipment should be stored in a controlled temperature, dry, and well-ventilated environment and protected from theft, dampness, fire, dirt, insects, rodents, and direct sunlight.
3. Do not store the equipment where it would prevent ventilation or interfere with light fixtures, heating vents, fire fighting devices, cooling units, exits, or fire doors.
4. Do not store LVADS Ancillary Equipment when it is damaged, dirty, or damp.
5. All stored items will be marked, segregated, and located for accessibility and easy identification.
6. Do not store equipment in direct contact with any building floor or wall. Use bins, shelves, pallets, racks, or dunnage to provide airspace between the storage area floor and the equipment. If preconstructed shelving or other storage accommodations are not available, fabricate storage provisions using suitable lumber or wooden boxes.
7. All available materials-handling equipment should be used as much as possible in the handling of airdrop items.
8. Periodic rotation of stock, conservation of available space, proper housekeeping policies and strict adherence to all safety regulations will be practiced at all times.

**Inspection.** In addition to the unit PMCS procedures, inspect the equipment for rips, tears, dirt, and missing components.

**Cleaning and Drying.** Clean and dry ancillary equipment in accordance with procedures described in WP 0008 00.

**PRESERVATION**

If the LVADS ancillary equipment is stored without regular PMCS being performed, consult TM 38-230-2 for preservation requirements.

**END OF WORK PACKAGE**



---

**SUPPORTING INFORMATION  
ANCILLARY EQUIPMENT FOR LOW VELOCITY AIR DROP SYSTEMS (LVADS)  
PREPARATION FOR SHIPMENT**

---

**THIS WORKPACKAGE COVERS:**

- In-Storage Inspection
  - Shipment
- 

**INITIAL SETUP:****Personnel Required**

92R(10) Parachute Rigger

**Equipment Condition**

Unpacked.

---

**IN-STORAGE INSPECTION**

**General Information.** An in-storage inspection is a physical check conducted on a random sample of airdrop equipment that is located in storage. Authorized rigger personnel (MOS 92R(20)) will conduct this inspection.

**Intervals.** Equipment in storage will be inspected at least semiannually and at more frequent intervals if prescribed by the local parachute maintenance officer.

**Inspection.** Inspect to ensure the equipment is ready for issue.

1. If necessary, check for proper identification.
2. Check that no damage or deterioration has been occurred.
3. Ensure that all modifications, or similar requirements, have been completed.
4. Check the adequacy of the storage facilities, efforts taken to control pests and rodents, and protection against unfavorable climatic conditions.

**SHIPMENT**

**Initial Shipment.** The initial packaging and shipping of equipment is the responsibility of item manufacturers, who are required to comply with federal and military packing specifications, as stipulated in contractual agreements. Equipment is normally shipped to depot activities, by domestic freight or parcel post, and packed to comply with overseas shipping requirements. Except for those pieces of equipment that are unpackaged and subjected to random inspections or testing by depot activity, equipment received by a using unit will be contained in the original packaging materials.

**END OF WORK PACKAGE**



---

**SUPPORTING INFORMATION  
ANCILLARY EQUIPMENT FOR LOW VELOCITY AIR DROP SYSTEMS (LVADS)  
REFERENCES**

---

**THIS WORKPACKAGE COVERS:**

- Scope
  - Publication Indexes
  - Pamphlets
  - Technical Manuals
  - Field Manuals
  - Miscellaneous
  - Army Regulations
  - Technical Bulletins
  - Forms
  - Air Force Technical Orders
  - Air Force Technical Order Forms
  - Marine Corps Forms
- 

**SCOPE**

This appendix lists all forms, technical manuals, and miscellaneous publications referenced in this manual.

**PUBLICATION INDEXES**

The following publication indexes should be consulted frequently for the latest changes or revisions of references given in this work package, and for new publications relating to the material covered in this manual:

**PAMPHLETS**

Consolidated Index of Army Publications and Blank Forms	DA PAM 25-30
Functional Users Manual for The Army Maintenance Management System (TAMMS)	DA PAM 738-750
Functional Users Manual for The Army Maintenance Management System (Aviation) (TAMMSA)	DA PAM 738-751

**TECHNICAL MANUALS**

General Maintenance of Parachutes and Other Airdrop Equipment	TM 10-1670-201-23/ T.O. 13C-1-41/ NAVAIR 13-1-17
Packaging of Material: Preservation (vol.1)	TM 38-230-1
Packaging of Material: Packing (vol.2)	TM 38-230-2
Procedures for the Destruction of Air Delivery Equipment to Prevent Enemy Use	TM 43-0002-1/ T.O. 13C3-1-10/ NAVAIR 13-1-19
Administrative Storage of Equipment	TM 740-90-1
Airdrop of Supplies and Equipment, General	TM 10-500
Procedures for Destruction of Equipment to Prevent Enemy Use	TM 750-244-3
Repair of Canvas and Webbing	TM 10-269
Storage and Materials Handling	TM 743-200-1
Technical Training of Parachutists	TM 57-220

**FIELD MANUALS**

Airdrop of Supplies and Equipment: Rigging Airdrop Platform	FM 4.20.120 (FM 10-500-2)
First Aid for Soldiers	FM 4-25.11 (FM 21-11)

**MISCELLANEOUS**

Abbreviations for Use on Drawings, and in Specifications, Standards, and Technical Documents	MIL-STD-12
Accounting for Lost, Damaged, and Destroyed Property	AR 735-11
Airdrop, Parachute Recovery and Aircraft Personnel Escape Systems	AR 750-32
Consolidated Index of Army Publications and Blank Forms	DA PAM 25-30
Functional User's Manual for the Army Maintenance Management System Aviation	DA PAM 738-751
Maintenance Expenditure Limits for FSC Group 16, Classes 1610, 1615, 1620, 1630, 1650, 1670, and 1680	TB 43-0002-4
Maintenance Expenditure Limits for FSC Group 16, Classes 1670	TB 43-0002-43
Army Material Maintenance Policy and Retail Maintenance Operations	AR 750-1
Military Standard Transportation and Movement Procedures (MILSTAMP)	AR 55-45
Packing of Army Material of Shipment and Storage	AR 746-1
Packaging of Material	AR 700-15
Reporting Unsatisfactory Newly Procured and Contractor Maintained Material	AR 702-1
The Army Maintenance Management System	DA PAM 738-750

**ARMY REGULATIONS**

Dictionary of United States Army Terms	AR 310-25
Authorized Abbreviations and Brevity Codes	AR 310-50
Packaging of Material	AR 700-15
Army Material Maintenance Policy and Retail Maintenance Operations	AR 750-1
Air Drop, Parachute Recovery and Aircraft Personnel Escape Systems	AR 750-32
Reporting of Supply Discrepancies	AR 735-11-2
Reporting of Transportation Discrepancies in Shipments	AR 55-38

---

**TECHNICAL BULLETINS**

Maintenance Expenditure Limits for FSC Group 16, FSC Class 1670 TB 43-0002-43

**FORMS**

Equipment Inspection & Maintenance Worksheet DA Form 2404

Equipment Log Assembly (Records)

Equipment Modification Record

Exchange Tag DA Form 2402

Forms. Recommended Changed to Publications and Blank Forms DA Form 2028

Maintenance Request DA Form 5504

Product Quality Deficiency Report SF 368

Recommended Changes to Equipment Technical Publications DA Form 2028-2

Report of Discrepancy SF 364

Transportation Discrepancy Report SF 361

**AIR FORCE TECHNICAL ORDERS**

Cleaning of Parachute Assemblies T.O. 14D1-1-2

Parachute Logs and Records T.O. DO-25-241

**AIR FORCE TECHNICAL ORDER FORMS**

Parachute Log AFTO 391

Parachute Repack Inspection and Component Card AFTO 392

**MARINE CORPS FORMS**

Marine Corps Military Incentive Awards Program MCO 1650.17F

Parachute History Record NAV WPN CEN or NAV  
WPNS CL 13512/11

Product Quality Deficiency Report (PQDR) MCO 4855.10B

Recommended Changes to Technical Publications NAVMC 10772





---

**SUPPORTING INFORMATION  
ANCILLARY EQUIPMENT FOR LOW VELOCITY AIR DROP SYSTEMS (LVADS)  
MAINTENANCE ALLOCATION CHART (MAC)**

---

**THIS WORK PACKAGE COVERS:**

- Introduction
  - Maintenance Functions
  - Explanation of Columns in the MAC
  - Explanation of Columns in Tool and Test Equipment Requirements
  - Explanation of Column in Remarks
- 

**INTRODUCTION****The Army Maintenance System MAC**

This introduction provides a general explanation of all maintenance and repair functions authorized at various maintenance levels under the standard Army Maintenance System concept.

The MAC (immediately following the introduction) designates overall authority and responsibility for the performance of maintenance functions on the identified end item or component. The application of the maintenance functions to the end item or component shall be consistent with the capacities and capabilities of the designated maintenance levels, which are shown on the MAC in column (4) as:

Unit — includes two subcolumns, C (operator/crew) and O (unit) maintenance.

Direct Support — includes an F subcolumn.

General Support — includes an H subcolumn.

Depot — includes a D subcolumn.

The tools and test equipment requirements (immediately following the MAC) list the tools and test equipment (both special tools and common tool sets) required for each maintenance function as referenced from the MAC.

The remarks (immediately following the tools and test equipment requirements) contain supplemental instructions and explanatory notes for a particular maintenance function.

**Maintenance Functions**

Maintenance functions are limited to and defined as follows:

1. Inspect. To determine the serviceability of an item by comparing its physical, mechanical, and/or electrical characteristics with established standards through examination (e.g., by sight, sound, or feel). This includes scheduled inspection and gagings and evaluation of cannon tubes.
2. Test. To verify serviceability by measuring the mechanical, pneumatic, hydraulic, or electrical characteristics of an item and comparing those characteristics with prescribed standards on a scheduled basis, i.e., load testing of lift devices and hydrostatic testing of pressure hoses.
3. Service. Operations required periodically to keep an item in proper operating condition; e.g., to clean (includes decontaminate, when required), to preserve, to drain, to paint, or to replenish fuel, lubricants, chemical fluids, or gases. This includes scheduled exercising and purging of recoil mechanisms.

4. Adjust. To maintain or regulate, within prescribed limits, by bringing into proper position, or by setting the operating characteristics to specified parameters.
5. Align. To adjust specified variable elements of an item to bring about optimum or desired performance.
6. Calibrate. To determine and cause corrections to be made or to be adjusted on instruments of test, measuring, and diagnostic equipment used in precision measurement. Consists of comparisons of two instruments, one of which is a certified standard of known accuracy, to detect and adjust any discrepancy in the accuracy of the instrument being compared.
7. Remove/Install. To remove and install the same item when required to perform service or other maintenance functions. Install may be the act of emplacing, seating, or fixing into position a spare, repair part, or module (component or assembly) in a manner to allow the proper functioning of an equipment or system.
8. Replace. To remove an unserviceable item and install a serviceable counterpart in its place. "Replace" is authorized by the MAC and assigned maintenance level is shown as the third position code of the Source, Maintenance and Recoverability (SMR) code.
9. Repair. The application of maintenance services, including fault location/troubleshooting, removal/installation, disassembly/assembly procedures, and maintenance actions to identify troubles and restore serviceability to an item by correcting specific damage, fault, malfunction, or failure in a part, subassembly, module (component or assembly), end item, or system.

#### NOTE

The following definitions are applicable to the "repair" maintenance function:

Services — Inspect, test, service, adjust, align, calibrate, and/or replace.

Fault location/troubleshooting — The process of investigating and detecting the cause of equipment malfunctioning; the act of isolating a fault within a system or Unit Under Test (UUT).

Disassembly/assembly — The step-by-step breakdown (taking apart) of a spare/functional group coded item to the level of its least component, that is assigned an SMR code for the level of maintenance under consideration (i.e., identified as maintenance significant).

Actions — Welding, grinding, riveting, straightening, facing, machining, and/or resurfacing.

10. Overhaul. That maintenance effort (service/action) prescribed to restore an item to a completely serviceable/operational condition as required by maintenance standards in appropriate technical publications. Overhaul is normally the highest degree of maintenance performed by the Army. Overhaul does not normally return an item to like new condition.
11. Rebuild. Consists of those services/actions necessary for the restoration of unserviceable equipment to a like new condition in accordance with original manufacturing standards. Rebuild is the highest degree of materiel maintenance applied to Army equipment. The rebuild operation includes the act of returning to zero those age measurements (e.g., hours/miles) considered in classifying Army equipment/components.

## Explanation of Columns in the MAC

Column (1) — Group Number. Column (1) lists FGC numbers, the purpose of which is to identify maintenance significant components, assemblies, subassemblies, and modules with the Next Higher Assembly (NHA).

Column (2) — Component/Assembly. Column (2) contains the item names of components, assemblies, subassemblies, and modules for which maintenance is authorized.

Column (3) — Maintenance Function. Column (3) lists the functions to be performed on the item listed in column (2). (For a detailed explanation of these functions refer to "Maintenance Functions" outlined above.)

Column (4) — Maintenance Level. Column (4) specifies each level of maintenance authorized to perform each function listed in column (3), by indicating work time required (expressed as man-hours in whole hours

or decimals) in the appropriate subcolumn. This work time figure represents the active time required to perform that maintenance function at the indicated level of maintenance. If the number or complexity of the tasks within the listed maintenance function varies at different maintenance levels, appropriate work time figures are to be shown for each level. The work time figure represents the average time required to restore an item (assembly, subassembly, component, module, end item, or system) to a serviceable condition under typical field operating conditions. This time includes preparation time (including any necessary disassembly/assembly time), troubleshooting/fault location time, and quality assurance time in addition to the time required to perform the specific tasks identified for the maintenance functions authorized in the MAC. The symbol designations for the various maintenance levels are as follows:

C — Operator or crew maintenance

O — Unit maintenance

F — Direct support maintenance

L — Specialized repair activity (SRA)

H — General support maintenance

D — Depot maintenance

### NOTE

The "L" maintenance level is not included in column (4) of the MAC. Functions to this level of maintenance are identified by a work time figure in the "H" column of column (4), and an associated reference code is used in the REMARKS column (6). This code is keyed to the remarks and the SRA complete repair application is explained there.

Column (5) — Tools and Equipment Reference Code. Column (5) specifies, by code, those common tool sets (not individual tools), common Test, Measurement and Diagnostic Equipment (TMDE), and special tools, special TMDE and special support equipment required to perform the designated function. Codes are keyed to the entries in the tools and test equipment table.

Column (6) — Remarks Code. When applicable, this column contains a letter code, in alphabetical order, which is keyed to the remarks table entries.

**Explanation of Columns in the Tools and Test Equipment Requirements**

Column (1) — Tool or Test Equipment Reference Code. The tool or test equipment reference code correlates with a code used in column (5) of the MAC.

Column (2) — Maintenance Level. The lowest level of maintenance authorized to use the tool or test equipment.

Column (3) — Nomenclature. Name or identification of the tool or test equipment.

Column (4) — National Stock Number (NSN). The NSN of the tool or test equipment.

Column (5) — Tool Number. The manufacturer's part number, model number, or type number.

**Explanation of Columns in the Remarks**

Column (1) — Remarks Code. The code recorded in column (6) of the MAC.

Column (2) — Remarks. This column lists information pertinent to the maintenance function being performed as indicated in the MAC.

**Table 1. Maintenance Allocation Chart For Ancillary Equipment for Low Velocity Air Drop System (LVADS)**

(1) GROUP NUMBER	(2) COMPONENT/ ASSEMBLY	(3) MAINTENANCE FUNCTION	(4) MAINTENANCE LEVEL					(5) TOOLS AND EQUIPMENT REFERENCE CODE	(6) REMARKS CODE
			UNIT		INTERMEDIATE	DEPOT			
			C	O	F	H	D		
01	Multi-Loop Line	Inspect Repair Replace		0.2 0.4 0.2				19, 41	A
02	Extraction Force Transfer Coupling	Inspect Repair Replace		0.5 1.0 0.1				2, 8, 9, 17, 45, 46, 50, 52, 54,56	A
0201	EFTC Adapter Link Assembly	Inspect Replace		0.1 0.1				56	A
0202	EFTC 3-Point Link Assembly	Inspect Replace		0.1 0.1				56	A
0203	EFTC Connector Latch Assembly	Inspect Replace		0.2 0.1				27, 57	A
0204	EFTC Latch Assembly Coupling	Inspect Replace		0.2 0.1				4, 14, 15, 21, 23, 26, 29, 49, 50	A
0205	EFTC Cable Assembly	Inspect Replace		0.3 0.1					A
0206	EFTC Actuator Assembly	Inspect Replace		0.2 0.1				45, 56	A

**Table 1. Maintenance Allocation Chart For  
Ancillary Equipment for Low Velocity Air Drop System (LVADS) - continued**

(1) GROUP NUMBER	(2) COMPONENT/ ASSEMBLY	(3) MAINTENANCE FUNCTION	(4) MAINTENANCE LEVEL					(5) TOOLS AND EQUIPMENT REFERENCE CODE	(6) REMARKS CODE
			UNIT		INTERMEDIATE		DEPOT		
			C	O	F	H	D		
03	M-1 Cargo Parachute Release	Inspect Repair Replace		0.3 0.6 0.1				2, 8, 9, 18, 19, 28, 30, 39, 40, 41, 52, 53, 58, 60	A
0301	Parachute Connector	Inspect Replace		0.1 0.1				5, 8, 9	A
0302	Timer Delay Assembly	Inspect Repair Replace		0.3 0.3 0.1				27, 30	A
04	M-2 Cargo Parachute Release	Inspect Repair Replace		0.3 0.6 0.1				2, 51, 58, 59	A
0401	Parachute Connector	Inspect Replace		0.1 0.1				5, 8, 9	A
0402	Timer Delay Assembly	Inspect Repair Replace		0.3 0.3 0.1				27, 30	A
05	Type IV Single Suspension Link Assembly	Inspect Replace		0.2 0.1					A
0501	Heavy-Duty Link Assembly	Inspect Replace		0.2 0.1				53, 56	A
0502	4-Point Link	Inspect Replace		0.2 0.1				53, 56	A
0503	Type IV Link Cover	Inspect Replace		0.1 0.1				18, 42	A
0504	Aerial Delivery Clevis	Inspect Replace		0.1 0.1				52, 53, 59	A
0505	Clevis Cover	Inspect Replace		0.1 0.1				11	A
0506	Single Knife Parachute Release Strap	Inspect Replace		0.1 0.1				44	A

**Table 1. Maintenance Allocation Chart For Ancillary Equipment for Low Velocity Air Drop System (LVADS) - continued**

(1) GROUP NUMBER	(2) COMPONENT/ ASSEMBLY	(3) MAINTENANCE FUNCTION	(4) MAINTENANCE LEVEL					(5) TOOLS AND EQUIPMENT REFERENCE CODE	(6) REMARKS CODE
			UNIT		INTERMEDIATE		DEPOT		
			C	O	F	H	D		
0507	Multi-Knife Parachute Release Strap	Inspect Replace		0.1 0.1				44	A
0508	3-Point Coupling Link Assembly	Inspect Replace		0.2 0.1				53, 56	A
0509	M-35 Suspension Bracket	Inspect Replace		0.1 0.1					A
0510	M-59 Suspension Bracket	Inspect Replace		0.1 0.1					A
0511	Suspension Plate	Inspect Replace		0.1 0.1					A
0512	10k Cargo Tie-down	Inspect Replace		0.1 0.1					A
0513	Quick Release Cargo Tie-down	Inspect Replace		0.1 0.1					A
0514	Type IV Drive-Off Aid	Inspect Replace		0.1 0.1					A
0515	Aircraft Cargo Tie-down	Inspect Replace		0.1 0.1					A
0516	3 ¾-IN., 2-Point Link	Inspect Replace		0.1 0.1				57	A
0517	5 ½-IN., 2-Point Link	Inspect Replace		0.1 0.1				57	A
0518	Release Away Static Line Assembly	Inspect Replace		0.2 0.1				19, 28	A
06	Extraction Parachute Jettison System (EPJS)	Inspect Assemble Test Disassemble		0.5 0.3 0.5 0.1				25, 43	A
0601	Extraction Parachute Jettison Device (EPJD), Squib, Squib Cable	Inspect Test Replace		0.2 0.1 0.4				16, 47, 62	A

**Table 1. Maintenance Allocation Chart For Ancillary Equipment for Low Velocity Air Drop System (LVADS) - continued**

(1) GROUP NUMBER	(2) COMPONENT/ ASSEMBLY	(3) MAINTENANCE FUNCTION	(4) MAINTENANCE LEVEL					(5) TOOLS AND EQUIPMENT REFERENCE CODE	(6) REMARKS CODE
			UNIT		INTERMEDIATE		DEPOT		
			C	O	F	H	D		
0602	Y-Connector	Inspect Test Repair Replace		0.1 0.2 0.3 0.1				25, 43	A
0603	Y-Connector Mounting Box (C-130, C-141, C-17)	Inspect Replace		0.1 0.1					A, B
0604	Y-Connector Mounting Box (C-5)	Inspect Replace		0.1 0.1					A, B
0605	Control Box	Inspect Test Repair Replace		0.2 0.2 0.3 0.1				22, 25, 27	A
0606	Squib Assembly	Inspect Test Repair		0.1 0.1 0.1					A, B
0607	EPJS Squib Cable	Inspect Test Replace		0.1 0.1 0.1					A
0608	10-Foot Platform Cable	Inspect Test Replace		0.1 0.3 0.1				27, 43	A, B
0609	10-Foot Interconnect Cable	Inspect Test Replace		0.1 0.2 0.1				25	A, B
0610	50-Foot Main Cable	Inspect Test Replace		0.1 0.2 0.1				27	A, B
0611	20-Foot Power Cable	Inspect Test Replace		0.1 0.2 0.1				27	A, B
0612	Protective Cover	Inspect Repair Replace		0.1 0.3 0.1				7, 12, 21, 31, 32, 33, 35	A

**Table 1. Maintenance Allocation Chart For Ancillary Equipment for Low Velocity Air Drop System (LVADS) - continued**

(1) GROUP NUMBER	(2) COMPONENT/ ASSEMBLY	(3) MAINTENANCE FUNCTION	(4) MAINTENANCE LEVEL					(4) TOOLS AND EQUIPMENT REFERENCE CODE	(5) REMARKS CODE
			UNIT		INTERMEDIATE		DEPOT		
			C	O	F	H	D		
0613	Kit Bag	Inspect Repair Replace		0.1 0.3 0.1				32, 33, 35	A
0614	4-Foot Extension Cable (C-5 and C-17)	Inspect Test Replace		0.1 0.3 0.1				27, 43	A, B
0615	Y-Connector Mounting Box Tie-Down Bracket (C-5)	Inspect Replace		0.1 0.1					A, B
0616	20-Foot Power Cable Extension (C-17)	Inspect Replace		0.1 0.1					A, B
0617	1-Foot Power Cable Adapter (C-5)	Inspect Replace		0.1 0.1					A, B
0618	Safety Cap	Inspect Replace		0.1 0.1					A, B
0619	Initiator Simulator	Inspect Test Replace		0.1 0.1 0.1				25	A, B
0620	Squib Tester	Inspect Test Repair Replace		0.1 0.1 0.2 0.1				25, 27	A
0621	28 VDC Power Supply	Inspect Replace		0.1 0.1					A
07	Link, Parachute Connector	Inspect Replace		0.1 0.1					A
<b>END OF TABLE</b>									



**Table 2. Tool and Test Equipment Requirements for Ancillary Equipment  
For Low Velocity Air Drop System (LVADS)**

(1) TOOL OR TEST EQUIPMENT REFERENCE CODE	(2) MAINTENANCE LEVEL	(3) NOMENCLATURE	(4) NATIONAL STOCK NUMBER	(5) TOOL NUMBER
1	O	10-Ounce, Weight	Locally Manufactured	N/A
2	O	Brush, Scrub, Household	7920-00-282-2490	H-B-1490
3	O	Brush, Stenciling	7520-00-248-9285	H-B-621
4	O	Brush, Wire, Stainless Steel	7920-00-269-1259	20010
5	O	Calipers	5210-01-010-4522	599-579-2
6	O	Compressor, Air Hose	Locally Manufactured	N/A
7	O	Die, Grommet Setting	3460-00-329-3346	9766
8	O	File, Bastard, 10-IN.	5110-00-234-6539	GGG-F-325
9	O	File, Bastard, 12-IN.	5110-00-239-7770	GGG-F-325
10	O	File, Flat	5110-00-249-2848	GGG-F-325
11	O	Grommet Punch		
12	O	Grommet, Metallic, Spur, Die Set, No. 2	5120-00-221-1148	MIL-P-16208
13	O	Hammer, Ball Peen, 16-ounce	5120-01-114-5499	GGG-H-86
14	O	Hex Key, Set	5120-00-935-4641	41W2455
15	O	Impact, Socket Set, Manual	5120-00-724-2145	PIT 2230 B
16	O	Kit, Tool, Refurbishment	NSN PENDING	811-00469
17	O	Knife	5110-00-162-2205	MIL-K-818C
18	O	Knife, Hot Metal	3439-01-197-7656	4025
19	O	Knife, Pocket	5110-00-240-5943	GGG-K-484
20	O	Machine, Stencil Cutting	7490-00-164-0537	A-A-2722
21	O	Mallet, Rawhide	5120-00-293-3397	GGG-H-33

**Table 2. Tool and Test Equipment Requirements for Ancillary Equipment  
For Low Velocity Air Drop System (LVADS) - continued**

(1) TOOL OR TEST EQUIPMENT REFERENCE CODE	(2) MAINTENANCE LEVEL	(3) NOMENCLATURE	(4) NATIONAL STOCK NUMBER	(5) TOOL NUMBER
22	O	Nut Driver, $\frac{3}{16}$ -IN.	5120-00-596-1263	A-A-2382
23	O	Pliers, Slip Joint (straight nose)	5120-00-224-2534	GGG-W-641
24	O	Pot, Melting, Electric	5120-00-924-5213	L-115
25	O	Power Supply, 28 VDC	6130-01-494-8726	611-00189
26	O	Punch, Hardened, 50 Rockwell, C Hardness or Higher, $\frac{3}{8}$ -IN. Diameter Point	5120-00-197-9490	GGG-P-831
27	O	Screwdriver, Cross-Tip, No. 1	5120-01-335-6883	A-A-2711
28	O	Screwdriver, Cross-Tip, No. 2	5120-01-335-6886	A-A-2711
29	O	Screwdriver, Cross-Tip, No. 3	5120-00-234-8912	19943
30	O	Screwdriver, Flat-Tip, $\frac{3}{16}$ -IN.	5120-00-277-7356	A-A-2711
31	O	Set, Chuck and Die	5120-00-694-5153	7540756
32	O	Sewing Machine, Darning, Industrial	3530-01-177-8589	00-5-00256/16
33	O	Sewing Machine, Darning, Industrial, Lock Stitch	3530-01-177-8589	00-S-00256/16
34	O	Sewing Machine, General Sewing, Industrial, 301 Stitch, Heavy-Duty	3530-01-177-8588	00-S-00256/13
35	O	Sewing Machine, General Sewing, Industrial, 301 Stitch, Medium-Duty	3530-01-177-8591	00-S-00256/13
36	O	Sewing Machine, General Sewing, Industrial, 301 Stitch; Light-Duty	3530-01-177-8590	00-S-00256/13
37	O	Sewing Machine, Industrial, 301 Stitch, Double Needle	3530-01-182-2873	00-S-00256/13
38	O	Sewing Machine, Industrial, 301 Stitch, Light, Heavy-Duty	3530-01-186-3079	00-S-00256/13

**Table 2. Tool and Test Equipment Requirements for Ancillary Equipment  
For Low Velocity Air Drop System (LVADS) - continued**

(1) TOOL OR TEST EQUIPMENT REFERENCE CODE	(2) MAINTENANCE LEVEL	(3) NOMENCLATURE	(4) NATIONAL STOCK NUMBER	(5) TOOL NUMBER
39	O	Sewing Machine, Zig-zag, Industrial, 308 Stitch, Light-Duty	3530-01-181-1420	00-S-00256/14
40	O	Sewing Machine, Zig-zag, Industrial, 308 stitch, Medium- Duty	3530-01-181-1421	00-S-00256/14
41	O	Shear, Trimmer	5110-00-596-9703	GGG-S-278
42	O	Shears	5110-00-223-6370	GGG-S-278
43	O	Simulator, Initiator	1670-01-496-4748	811-00444
44	O	Stone Sharpening, Round	Local Purchase	N/A
45	O	Straight Edge, 2-IN.	6675-00-190-5850	A-A-843
46	O	Tape Measure, 25-FT	5210-01-139-7444	DLT-125H
47	O	Tester, Squib	6625-01-495-2015	811-00491
48	O	Timer, 15 Second	1670-00-400-2772	11-1-894-1
49	O	Wrench, Adjustable, 10-IN.	5120-00-449-8083	5385A14
50	O	Wrench, Open End, $\frac{7}{16}$ -IN.	5120-00-228-9505	1214
51	O	Wrench, Open-End, $\frac{3}{4}$ -IN. and $\frac{13}{16}$ -IN.	5120-00-187-7129	A-A-1356
52	O	Wrench, Open-End, 1 $\frac{1}{4}$ -IN. and 1 $\frac{5}{16}$ -IN.	5120-00-277-2321	A-A-1356
53	O	Wrench, Open-End, 1 $\frac{1}{2}$ -IN. and 1 $\frac{3}{4}$ -IN.	5120-00-277-9818	A-A-1356
54	O	Wrench, Open-End, 1 $\frac{1}{16}$ and 1 $\frac{1}{8}$ -IN.	5120-00-293-0190	A-A-1356
55	O	Wrench, Open-End, 1 $\frac{1}{8}$ -IN. and 1 $\frac{1}{4}$ -IN.	5120-00-277-2694	A-A-1356
56	O	Wrench, Open-End, 1 $\frac{7}{16}$ -IN. and 1 $\frac{5}{8}$ -IN.	5120-00-277-2326	A-A-1356
57	O	Wrench, Open-End, 1 and 1 $\frac{1}{8}$ - IN.	5120-00-187-7133	A-A-1356
58	O	Wrench, Open-End, $\frac{13}{16}$ -IN. and $\frac{7}{8}$ -IN.	5120-00-187-7130	A-A-1356

**Table 2. Tool and Test Equipment Requirements for Ancillary Equipment For Low Velocity Air Drop System (LVADS) - continued**

(1) TOOL OR TEST EQUIPMENT REFERENCE CODE	(2) MAINTENANCE LEVEL	(3) NOMENCLATURE	(4) NATIONAL STOCK NUMBER	(5) TOOL NUMBER
59	O	Wrench, Open-End, <sup>15</sup> / <sub>16</sub> -IN. and 1-IN.	5120-00-277-7025	A-A-1356
60	O	Wrench, Open-End, <sup>5</sup> / <sub>8</sub> -IN. and <sup>9</sup> / <sub>16</sub> -IN.	5120-00-187-7126	A-A-1356
61	O	Wrench, Open-End, <sup>7</sup> / <sub>16</sub> -IN. and <sup>1</sup> / <sub>2</sub> -IN.	5120-00-187-7123	A-A-1356
62	O	Wrench, Torque, 0-150-IN.-pounds, needle on dial	5120-01-396-5684	1502LDIN
63	O	Yardstick	5120-00-985-6610	GGG-Y-0035
<b>END OF TABLE</b>				

**Table 3. Remarks for Ancillary Equipment for the Low Velocity Airdrop System**

REMARKS CODE	REMARKS
A	Is a Technical/Rigger inspection.
B	Repair is limited to replacement of defective components.

END OF WORK PACKAGE

**SUPPORTING INFORMATION  
 ANCILLARY EQUIPMENT FOR LOW VELOCITY AIR DROP SYSTEM (LVADS)  
 REPAIR PARTS AND SPECIAL TOOLS LIST (RPSTL), INTRODUCTION**

**SCOPE**

This manual lists and authorizes spare and repair parts; special tools; special test, measurement, and diagnostic equipment (TMDE); and other special support equipment required for performance of organizational, direct support, and general support maintenance of the ancillary equipment. It authorizes the requisitioning, issue, and disposition of spares, repair parts and special tools, as indicated by the Source, Maintenance and Recoverability (SMR) codes.

**GENERAL**

In addition to the Introduction work package, this RPSTL is divided into the following work packages:

**Repair Parts List Work Packages.** Work packages containing lists of spares and repair parts authorized by this RPSTL for use in the performance of maintenance. These work packages also include parts that must be removed for replacement of the authorized parts. Parts lists are composed of functional groups in ascending alphanumeric sequence, with the parts in each group listed in ascending figure, and item number sequence. Sending units, brackets, filters, and bolts are listed with the component they mount on. Bulk materials are listed by item name in FIG. BULK at the end of the work packages. Repair parts kits are listed separately in their own functional group and work package. Repair parts for reparable special tools are also listed in a separate work package. Items listed are shown on the associated illustrations.

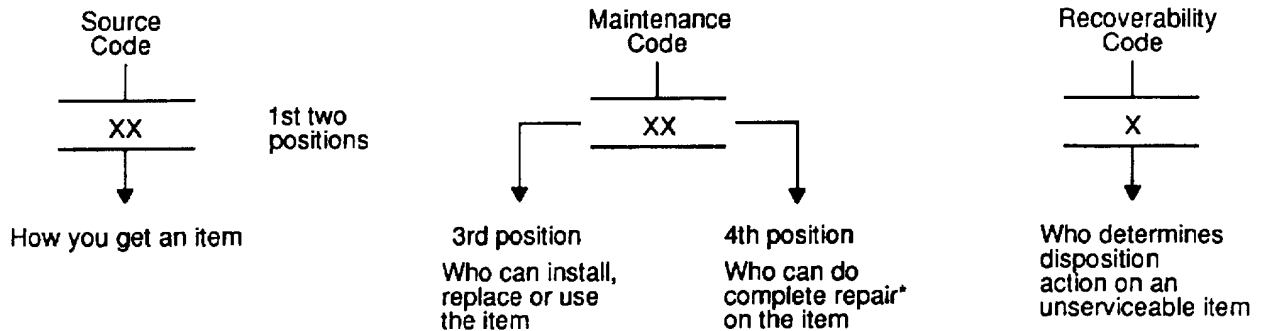
**Special Tools List Work Package.** Work packages containing lists of special tools, special TMDE, and special support equipment authorized by this RPSTL (as indicated by Basis of Issue (BOI) information in the DESCRIPTION AND USABLE ON CODE (UOC) column.) Tools that are components of common tool sets and/or Class VII are not listed.

**Cross Reference Indexes Work Package.** There are two cross-reference indexes work packages in this RPSTL: the National Stock Number (NSN) Index work package, and the Pat Number (P/N) Index work package. The National Stock Number Index work package refers you to the figure and item number. The Pat Number Index work package refers you to the figure and item number.

**EXPLANATION OF COLUMNS**

**Column 1, Item No.** Indicates the number used to identify items called out in the illustration.

**Column 2, SMR Code.** The Source, Maintenance, and Recoverability (SMR) code is a 5-position code containing supply/requisitioning information, maintenance category authorization criteria, and disposition instructions, as shown in the following breakout:



\*Complete Repair: Maintenance capacity, capability, and authority to perform all the corrective maintenance tasks of the REPAIR function in a use/user environment in order to restore serviceability to a failed item.

**Source Code.** The source code tells you how to get an item needed for maintenance, repair, or overhaul of an end item/equipment. Source codes are always the first and second positions of the SMR code. Explanations of source codes follow:

SOURCE CODE	EXPLANATION
PA	Stock items; use the applicable NSN to requisition/request items with these source codes. They are authorized to the level indicated by the code entered in the 3 <sup>rd</sup> position of the SMR code.
PB	
PC	
PD	
PE	
PF	
PG	
	<b>NOTE</b>
	Items coded PC are subject to deterioration.
	Items with these codes are not to be requested/requisitioned individually. They are part of a kit that is authorized to the maintenance level indicated in the 3 <sup>rd</sup> position of the SMR code. The complete kit must be requisitioned and applied.
	Items with these codes are not to be requisitioned/requested individually. They must be made from bulk material that is identified by the P/N in the DESCRIPTION and USABLE ON CODE (UOC) column and listed in the bulk material group work package of the RPSTL. If the item is authorized to you by the 3 <sup>rd</sup> position code of the SMR code, but the source code indicates it is made at a higher level, order the item from the higher level of maintenance.
MO – (Made at unit/AVUM Level)	
MF – (Made at DS/AVIM Level)	
MH – (Made at GS Level)	
ML – (Made at SRA)	
MD – (Made at Depot)	
AO – (Assembled by unit AVUM Level)	Items with these codes are not to be requested/requisitioned individually. The parts that make up the assembled item must be requisitioned or fabricated and assembled at the level of maintenance indicated by the source code. If the 3 <sup>rd</sup> position code of the SMR code authorizes you to replace the item, but the source code indicates the item is assembled at a higher level, order the item from the higher level of maintenance.
AF – (Assembled by DS/AVIM Level)	
AH – (Assembled by GS Level)	
AL – (Assembled by SRA)	
AD – (Assembled by Depot)	
XA -	Do not requisition an XA-coded item. Order the next higher assembly. (Refer to the NOTE below.)
XB -	If an item is not available from salvage, order it using the CAGEC and P/N.

**SOURCE CODE – continued**

**EXPLANATION - continued**

XC -	Installation drawings, diagrams, instruction sheets, field service drawings; identified by manufacturer's P/N.
XD -	Item is not stocked. Order an XD-coded item through normal supply channels using the CAGEC and P/N given, if no NSN is available.

NOTE

Cannibalization or controlled exchanged, when authorized, may be used as a source of supply for items with the above source codes, except for those source coded XA or those aircraft support items restricted by requirements of AR 750-1.

**Maintenance Code.** Maintenance codes tell you the level(s) of maintenance authorized to use and repair support items. The maintenance codes are entered in the third and fourth positions of the SMR Code as follow:

**Third position.** The maintenance code entered in the third position tells you the lowest maintenance level authorized to remove, replace, and use an item. The maintenance code entered in the third position will indicate authorization to one of the following levels of maintenance.

**MAINTENANCE CODE**

**APPLICATION/EXPLANATION**

C -	Crew or operator maintenance done within unit/AVUM maintenance.
O -	Unit level/AVUM maintenance can remove, replace, and use the item.
F -	Direct support/ AVIM maintenance can remove, replace, and use the item.
H -	General support maintenance can remove, replace, and use the item.
L -	Specialized repair activity can remove, replace, and use the item.
D -	Depot can remove, replace, and use the item.

**Fourth position.** The maintenance code entered in the fourth position tells you whether or not the item is to be repaired and identifies the lowest maintenance level with the capability to do complete repair (perform all authorized repair functions).

NOTE

Some limited repair may be done on the item at a lower level of maintenance, if authorized by the Maintenance Allocation Chart (MAC) and SMR code.

MAINTENANCE CODE	APPLICATION/ EXPLANATION
O -	Unit/AVUM is the lowest level that can do complete repair of the item.
F -	Direct support/AVIM is the lowest level that can do complete repair of the item.
H -	General support is the lowest level that can do complete repair of the item.
L -	Specialized repair activity (designate the specialized repair activity) is the lowest level that can do complete repair of the item.
D -	Depot is the lowest level that can do complete repair of the item.
Z -	Non-repairable. No repair is authorized.
B -	No repair is authorized. No parts or special tools are authorized for the maintenance of a B-coded item. However, the item may be reconditioned by adjusting, lubricating, etc., at the user level.

**Recoverability code.** Recoverability codes are assigned to items to indicate the disposition action on unserviceable items. The recoverability code is entered in the **fifth position** of the SMR code as follows:

RECOVERABILITY CODE	APPLICATION/EXPLANATION
Z -	Non-repairable item. When unserviceable, condemn and dispose of the item at the level of maintenance shown in the third position of the SMR Code.



**RECOVERABILITY CODE – continued**

**APPLICATION/EXPLANATION - continued**

O -	Repairable item. When uneconomically repairable, condemn and dispose of the item at the unit level.
F -	Repairable item. When uneconomically repairable, condemn and dispose of the item at the direct support level.
H -	Repairable item. When uneconomically repairable, condemn and dispose of the item at the general support level.
D -	Repairable item. When beyond the lower level repair capability, return to depot. Condemnation and disposal of item not authorized below depot level.
L -	Repairable item. Condemnation and disposal not authorized below Specialized Repair Activity (SRA).
A -	Item requires special handling or condemnation procedures because of specific reasons (such as, precious metal content, high dollar value, critical material or hazardous material). Refer to appropriate manuals/directives for specific instructions.

**Column 3, NSN.** The NSN for the item is listed in this column.

**Column 4, CAGEC.** The Commercial and Government Entity Code (CAGEC) is a five-digit numeric code that is used to identify the manufacturer, distributor, or Government agency that supplies the item.

**Column 5, Part Number.** Indicates the primary number used by the manufacturer (individual, company, firm, corporation, or Government activity), which controls the design and characteristics of the item by means of its engineering drawings, specifications, standards, and inspection requirements to identify an item or range of items.

NOTE

When you use an NSN to requisition an item, the item you receive may have a different P/N from the part ordered.

**Column 6, Description and Usable on Code (UOC).** This column includes the following information:

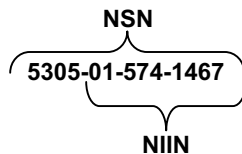
1. The federal item name and, when repaired, a minimum description to identify the item.
2. P/Ns for bulk materials are referenced in this column in the line entry for the to be manufactured or fabricated.
3. Hardness Critical Item (HCI). A support item that provides the equipment with special protection from electromagnetic pulse (EMP) damage during a nuclear attack.
4. The statement END OF FIGURE appears just below the last item description in column (6) for a given figure in both the repair parts list and special tools list work packages.

**Column 7, QTY.** The QTY (quantity per figure) column indicates the quantity of the item used in the breakout shown on the illustration/figure, which is prepared for a functional group, sub-functional group, or an assembly. A "V" appearing in the column instead of a quantity indicates that the quantity is variable and quantity may change from application to application.

## EXPLANATION OF COLUMNS

### 1. National Stock Number (NSN) Index Work Package.

**STOCK NUMBER Column.** This column lists the NSN by National Item Identification Number (NIIN) sequence. The NIIN consists of the last nine digits of the NSN, i.e.



When using this column to locate an item, ignore the first 4 digits of the NSN. However, the complete NSN should be used when ordering items by stock number.

**FIG. column.** This column lists the number of the figure where the item is identified/located. The figures are in numerical order in the repair parts list and special tools list work packages.

**ITEM column.** The item number identifies the item associated with the figure listed in the adjacent FIG. column. This item is also identified by the NSN listed on the same line.

### 2. Part Number (P/N) Index Work Package.

P/Ns in this index are listed in ascending alphanumeric sequence (vertical arrangement of letter and number combinations which places the first letter or digit of each group in order A through Z, followed by the numbers 0 through 9 and each following letter or digit in like order).

**PART NUMBER Column.** Indicates the P/N assigned to the item.

**FIG. Column.** This column lists the number of the figure where the item is identified/located in the repair parts list and special tools list work packages.

ITEM Column. The item number is the number assigned to the item as it appears in the figure referenced in the adjacent figure number column.

### SPECIAL INFORMATION

The Usable on Code title appears in the lower right corner of column (5), Description. Usable on codes are shown in the right-hand margin of the description column. Identification of the usable on codes used in the RPSTL are:

Code:	Used on:
N/A	N/A

Fabrication Instructions. Bulk materials required to manufacture items are listed in the bulk material functional group of this RPSTL. Part numbers for bulk material are also referenced in the Description Column of the line item entry for the item to be manufactured/fabricated. Detailed fabrication instructions for items source coded to be manufactured or fabricated are found in this TM.

Index Numbers. Items that have the word BULK in the figure column will have an index number shown in the item number column. This index number is a cross-reference between the NSN / P/N index work packages and the bulk material list in the repair parts list work package.

Illustration List. The illustrations in this RPSTL contain unit authorized items. Illustrations published in this TM that contain unit authorized items also appear in this RPSTL. The tabular list in the repair parts list work package contains only those parts coded "O" in the third position of the SMR code, therefore, there may be a break in the item number sequence.

### HOW TO LOCATE REPAIR PARTS

#### 1. When National Stock Number or Part Number is Not Known.

First. Using the table of contents, determine the assembly group or sub-functional group to which the item belongs. This is necessary since the figures are prepared for functional groups and sub-assembly groups, and lists are divided into the same groups.

Second. Find the item covering the figure covering the functional group or sub-functional group to which the item belongs.

Third. Identify the item on the figure and note the number(s).

Fourth. Look in the repair parts list work packages for the figure and item numbers. The NSNs and part numbers are on the same line as the associated item numbers.

#### 2. When NSN is Known.

First. If you have the NSN, look in the STOCK NUMBER column of the NSN index work package. The NSN is arranged in NIIN sequence. Note the figure and item number next to the NSN.

Second. Turn to the figure and locate the item number. Verify that it is the one you are looking for.

**3. When P/N is Known.**

First. If you have the P/N and not the NSN, look in the PART NUMBER column of the P/N index work package. Identify the figure and item number.

Second. Look up the item on the figure in the applicable repair parts list work package.

**END OF WORK PACKAGE**



GROUP 01 MULTI-LOOP LINE

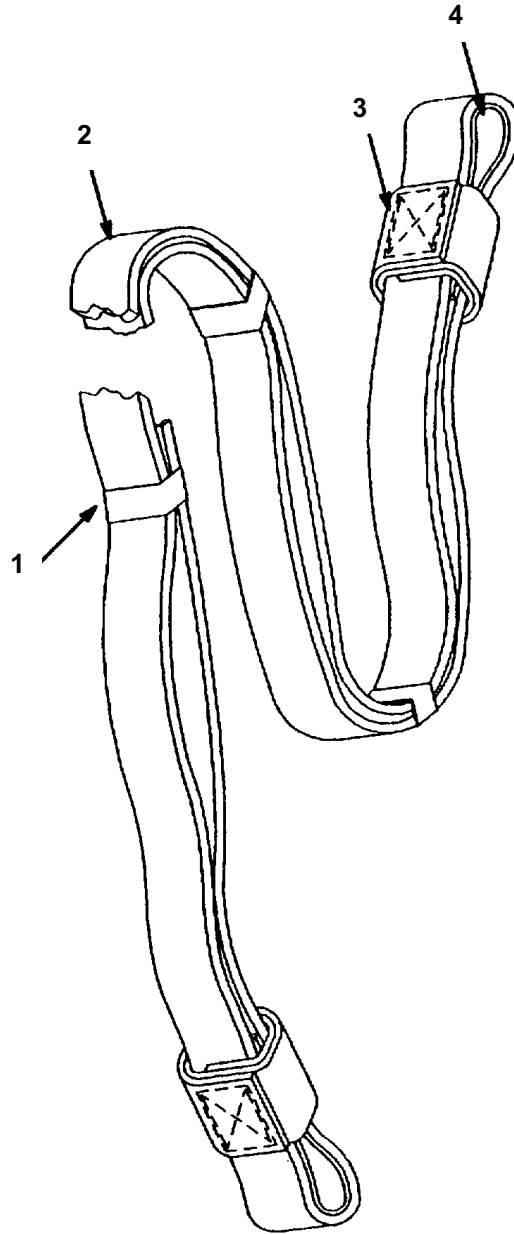


Figure 1. Typical Multi-Loop Line

**GROUP 01 MULTI-LOOP LINE**

(1) ITEM NO.	(2) SMR CODE	(3) NSN	(4) CAGEC	(5) PART NUMBER	(6) DESCRIPTION AND USABLE ON CODE (UOC)	(7) QTY
Group 01, Multi-Loop Line Figure 1, Typical Multi-Loop Line						
1	PAOZZ	7510-00-053-0942	81337	PPP-T-97 TY4	Keeper, Fixed	V
2	PAOOO	1670-01-062-6301 1670-01-062-6306 1670-01-062-6304 1670-01-062-6305 1670-01-063-7760 1670-01-062-6310 1670-01-062-6303 1670-01-062-6307 1670-01-063-7761 1670-01-062-6308 1670-01-062-6302 1670-01-064-4453 1670-01-062-6309 1670-01-064-4451 1670-01-064-4452	81337	68F217-48 68F217-52 68F217-49 68F217-53 68F217-58 68F217-59 68F217-50 68F217-54 68F217-22 68F217-55 68F217-51 68F217-56 68F217-57 68F217-47 68F217-45	Line, Multi-loop, 2-Loop, 3-FT Line, Multi-Loop, 4- Loop, 3-FT Line, Multi-Loop, 2- Loop, 9-FT Line, Multi-Loop, 4- Loop, 9-FT Line, Multi-Loop, 2- Loop, 11-FT Line, Multi-Loop, 4- Loop, 11-FT Line, Multi-Loop, 2- Loop, 12-FT Line, Multi-Loop, 4- Loop, 12-FT Line, Multi-Loop, 2- Loop, 16-FT Line, Multi-Loop, 4- Loop, 16-FT Line, Multi-Loop, 2- Loop, 20-FT Line, Multi-Loop, 4- Loop, 20-FT Line, Multi-Loop, 4- Loop, 28-FT Line, Multi-Loop, 1- Loop, 36-FT Line, Multi-Loop, 1- Loop, 60-FT	V

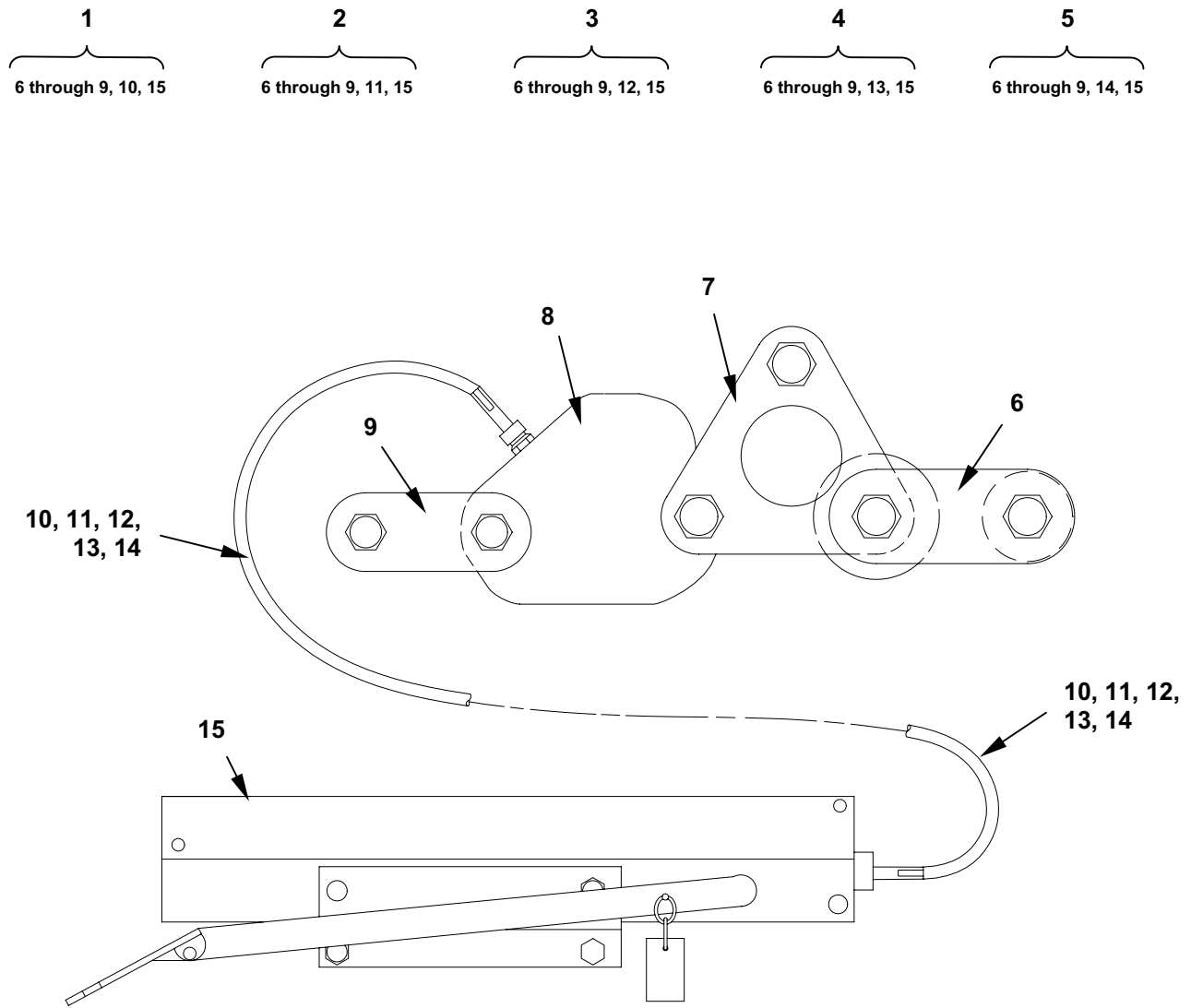
**GROUP 01 MULTI-LOOP LINE**

(1) ITEM NO.	(2) SMR CODE	(3) NSN	(4) CAGEC	(5) PART NUMBER	(6) DESCRIPTION AND USABLE ON CODE (UOC)	(7) QTY
2	PAOOO	1670-01-062-6313  1670-01-064-4454  1670-01-062-6311  1670-01-062-6312  1670-01-107-7651  1670-01-107-7652	81337	68F217-30  68F217-32  68F217-41  68F217-33  68F217-60  68F217-61	Line, Multi-Loop, 3- Loop, 60-FT  Line, Multi-Loop, 6- Loop, 60-FT  Line, Multi-Loop, 2- Loop, 120-FT  Line, Multi-Loop, 6- Loop, 120-FT  Line, Multi-Loop, 3- Loop, 140-FT  Line, Multi-Loop, 1- Loop, 160-FT	V
3	MOOZZ		81337	68F217-2	Keeper, Sliding	2
4	MOOZZ		81337	68F217-5	Buffer	2
<b>END OF FIGURE</b>						





**GROUP 02 EXTRACTION FORCE TRANSFER COUPLING**



**Figure 2. Extraction Force Transfer Coupling**

**GROUP 02 EXTRACTION FORCE TRANSFER COUPLING  
REPAIR PARTS LIST**

(1) ITEM NO.	(2) SMR CODE	(3) NSN	(4) CAGEC	(5) PART NUMBER	(6) DESCRIPTION AND USABLE ON CODE (UOC)	(7) QTY
Group 02, Extraction Force Transfer Coupling Figure 2, Extraction Force Transfer Coupling						
	XCOOO		81337	11-1-2060	Coupling, Extraction Force Transfer	V
1	PAOOO	1670-00-434-5783	81337	11-1-2060-1	Coupling Assembly, Airdrop, 12-FT	V
2	PAOOO	1670-00-434-5785	81337	11-1-2060-2	Coupling Assembly, Airdrop, 16-FT	V
3	PAOOO	1670-00-434-5787	81337	11-1-2060-3	Coupling Assembly, Airdrop, 20-FT	V
4	PAOOO	1670-00-434-5782	81337	11-1-2060-4	Coupling Assembly, Airdrop, 24-FT	V
5	PAOOO	1670-01-326-7309	81337	11-1-2060-5	Coupling Assembly, Airdrop, 28-FT	V
6	PAOOO	1670-00-162-4979	81337	11-1-1721	Adapter, Link Assembly	2
7	PAOOO	1670-00-162-4981	81337	11-1-1715-1	Link Assembly, Coupling	2
8	PAOOO	1670-01-470-3696	81337	11-1-1725	Latch Assembly, Coupling	1
9	PAOOO	1670-01-470-8333	81337	11-1-3924	Latch Assembly, Connector	2
10	PAOZZ	1670-00-434-5797	81337	11-1-2061-1	Cable Assembly, Coupling 12-FT	
11	PAOZZ	1670-00-434-5798	96906	11-1-2061-2	Cable Assembly, Coupling, 16-FT	2
12	PAOZZ	1670-00-434-5795	96906	11-1-2061-3	Cable Assembly, Coupling, 20-FT	2
13	PAOZZ	1620-01-434-5796	81337	11-1-2061-4	Cable Assembly, Coupling, 24-FT	1
14	PAOZZ	1670-00-157-6527	81337	11-1-2061-5	Cable Assembly, Coupling, 28-FT	2
15	PAOOO	1670-01-182-1979	81337	11-1-1737	Actuator Assembly	2
<b>END OF FIGURE</b>						





GROUP 0201 EXTRACTION FORCE TRANSFER COUPLING ADAPTER LINK ASSEMBLY

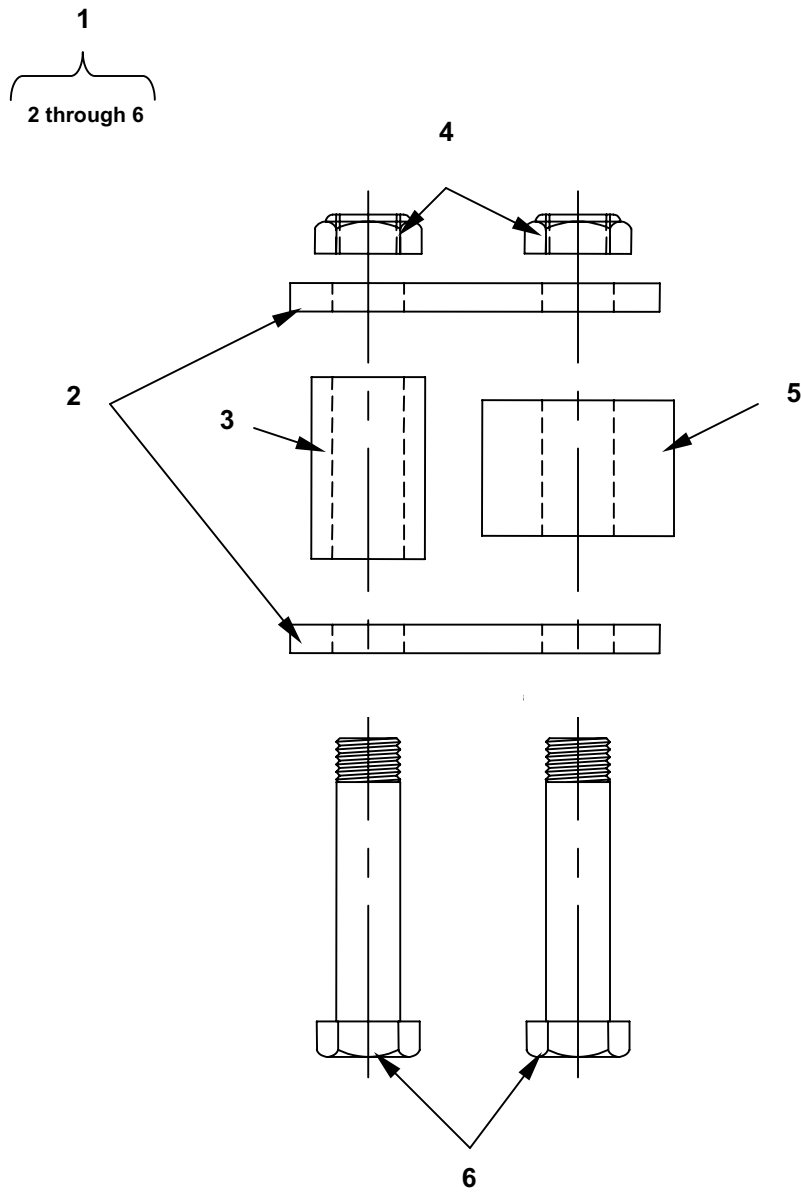


Figure 3. Link Assembly Adapter

**GROUP 0201 ADAPTER LINK ASSEMBLY  
REPAIR PARTS LIST**

(1) ITEM NO.	(2) SMR CODE	(3) NSN	(4) CAGEC	(5) PART NUMBER	(6) DESCRIPTION AND USABLE ON CODE (UOC)	(7) QTY
Group 03, Extraction Force Transfer Coupling Adapter Link Assembly Figure 3, Extraction Force Transfer Coupling Adapter Link Assembly						
1	PAOOO	1670-00-162-4979	81337	11-1-1721	Adapter, Link Assembly	1
2	PAOZZ	5365-01-354-8932	81337	11-1-1722	Spacer, Plate	2
3	PAOZZ	5365-00-180-5850	81337	11-1-1723	Spacer, Sleeve	1
4	PAOZZ	5310-00-776-1963	96906	MS21083/N16	Nut, Self-Locking, 1-IN., 1-UNJF-3B	2
5	XDOZZ		81337	11-1-1724	Spacer, Sleeve	1
6	PAOZZ	5306-01-471-5421	81337	11-1-3910-3	Screw, Cap, Hexagon	2
<b>END OF FIGURE</b>						







GROUP 0202 EFTC 3-POINT COUPLING LINK ASSEMBLY

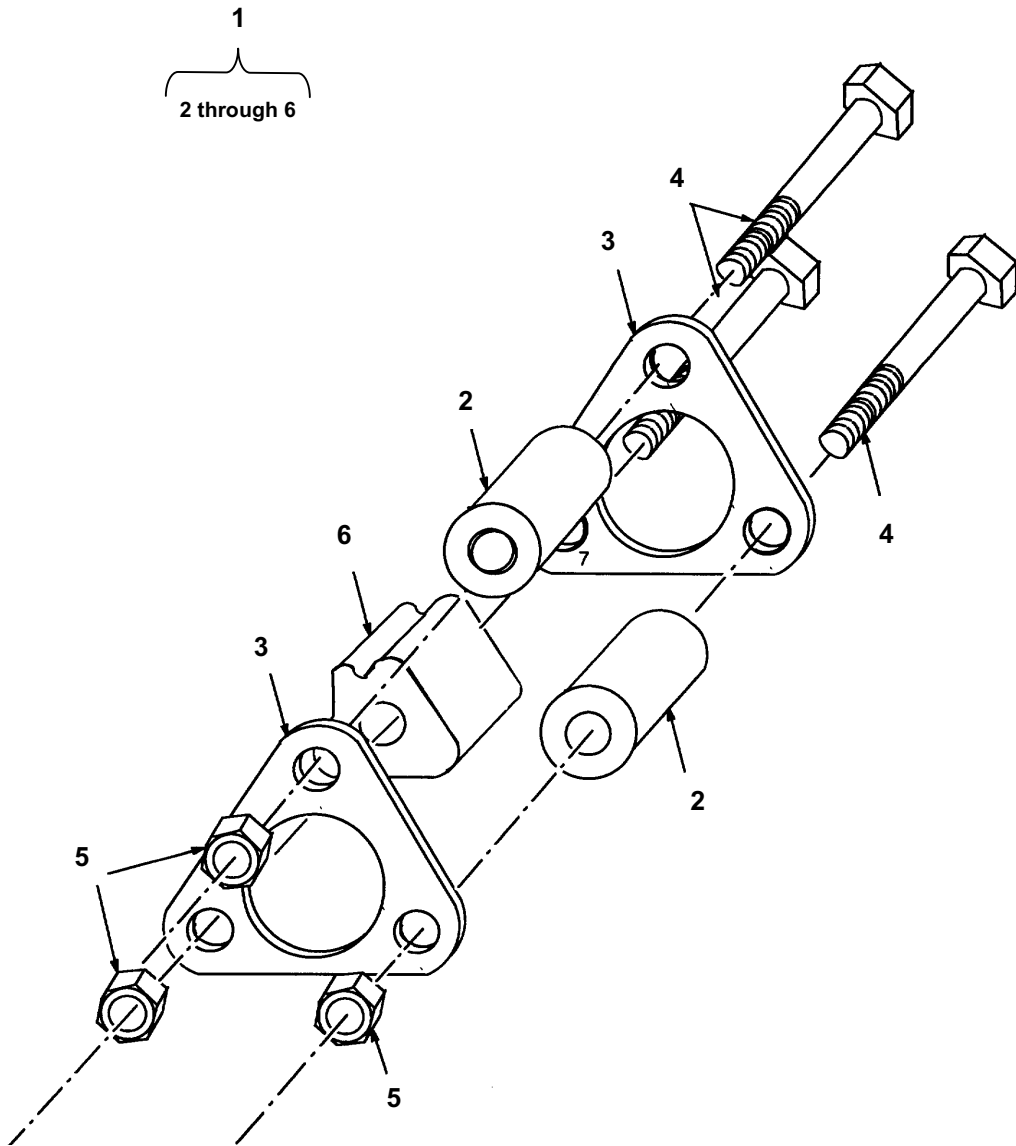


Figure 4. EFTC Coupling Link Assembly

**GROUP 0202 EFTC 3-POINT COUPLING LINK ASSEMBLY**

(1) ITEM NO.	(2) SMR CODE	(3) NSN	(4) CAGEC	(5) PART NUMBER	(6) DESCRIPTION AND USABLE ON CODE (UOC)	(7) QTY
Group 04, EFTC 3-Point Coupling Link Assembly Figure 4, EFTC 3-Point Coupling Link Assembly						
1	PAOOO	1670-00-162-4981	81337	11-1-1715-1	Link Assembly, Coupling	1
2	PAOZZ	5365-00-405-9293	81337	11-1-1718	Spacer, Sleeve	2
3	XAOZZ		81337	11-1-1717	Plate, Slide	2
4	PAOZZ	5306-01-471-5336	81337	11-1-3910-1	Screw, Cap, Hexagon	3
5	PAOZZ	5310-00-776-1963	96906	MS21083-N16	Nut, Self-Locking, 1-IN., 1-UNJF-3B	3
6	XAOZZ		81337	11-1-1716	Cam	1
<b>END OF FIGURE</b>						





GROUP 0203 EFTC CONNECTOR LATCH ASSEMBLY COUPLING

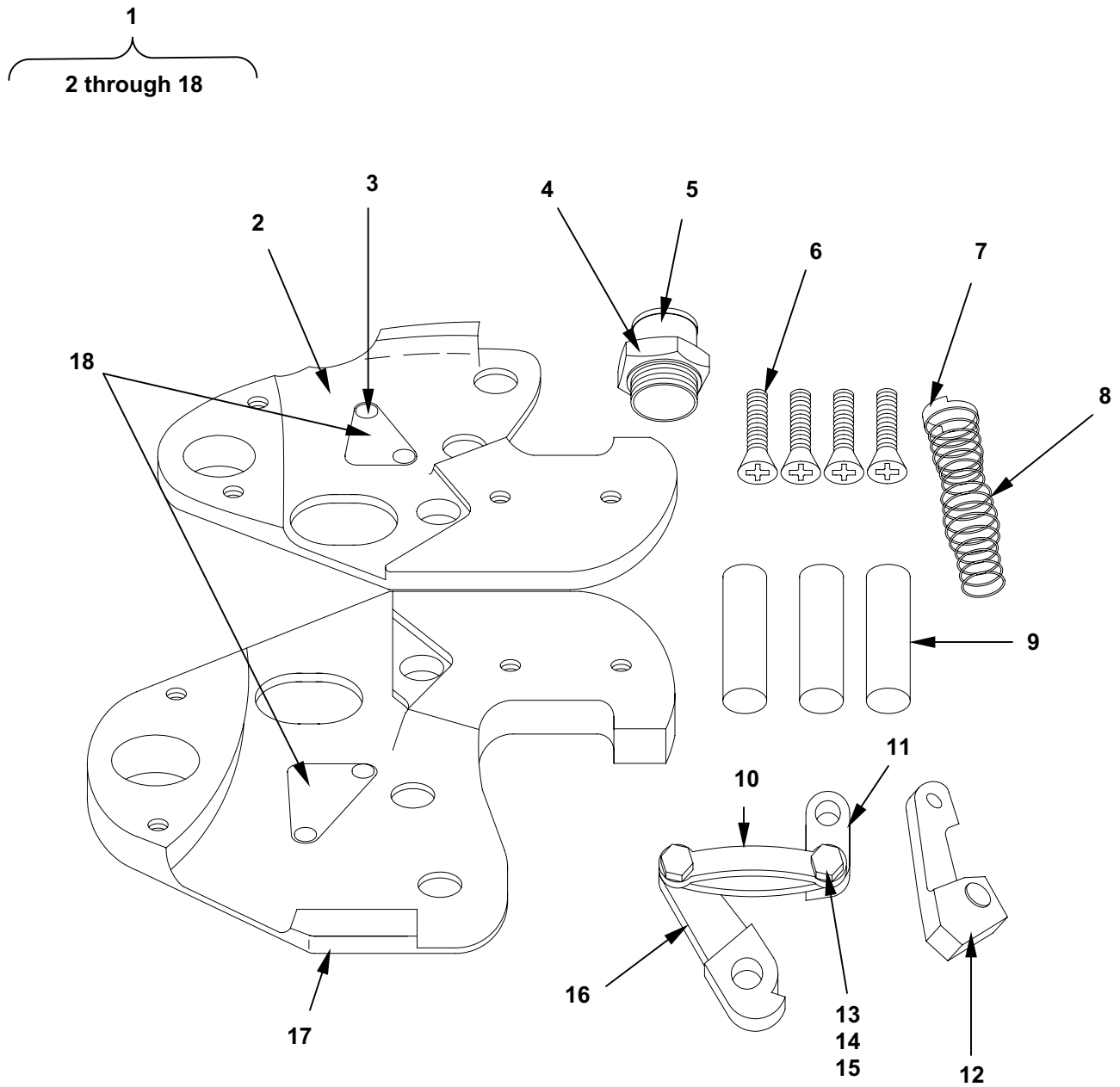


Figure 5. Latch Assembly Coupling

**GROUP 0203 LATCH ASSEMBLY COUPLING  
REPAIR PARTS LIST**

(1) ITEM NO.	(2) SMR CODE	(3) NSN	(4) CAGEC	(5) PART NUMBER	(6) DESCRIPTION AND USABLE ON CODE (UOC)	(7) QTY
Group 0203, EFTC Connector Latch Assembly Coupling Figure 5, Latch Assembly Coupling						
1	PAOOO	1670-01-470-3696	81337	11-1-1725	Latch Assembly, Coupling	1
2	XAOZZ		81337	11-1-1727-3	Plate, Side, Left	1
3	PAOZZ	5320-00-117-6829	96906	MS20470AD4-7	Rivet, Solid	4
4	PAOZZ	5310-00-939-0783	96906	MS21083-N12	Nut, Self-locking, 3/4- IN., 18-UNJF	1
5	XAOZZ		81337	11-1-1734	Retainer, Upper	1
6	PAOZZ	5305-00-058-4007	96906	MS24694S115	Screw, Machine, 1/4- IN., 28-UNF	4
7	XAOZZ		81337	11-1-1735	Retainer, Lower	1
8	XAOZZ		81337	11-1-1736	Spring, Catch	1
9	XAOZZ		81337	11-1-1731	Pin	3
10	XAOZZ		81337	11-1-1728	Link, Idler	1
11	XAOZZ		81337	11-1-1730	Link, Lock	1
12	XAOZZ		81337	11-1-1729	Catch	1
13	XAOZZ		81337	11-1-1732	Sleeve, Idler, Link	2
14	PAOZZ	5310-00-582-5965	96906	MS35338-44	Washer, Lock, 1/4-IN., 18-UNJF	2
15	PAOZZ	5305-00-267-8953	80204	B1821BH025F063N	Screw Cap, Hex HD, .250-28UNF-28UNF- 2AX .62LG, Type II	2
16	XAOZZ		81337	11-1-1726	Hook Retainer	1
17	XAOZZ		81337	11-1-1727-5	Plate, Side Right	1
18	XAOZZ		81337	11-1-1733	Pad, Friction	2
<b>END OF FIGURE</b>						







GROUP 0204 CONNECTOR LATCH ASSEMBLY

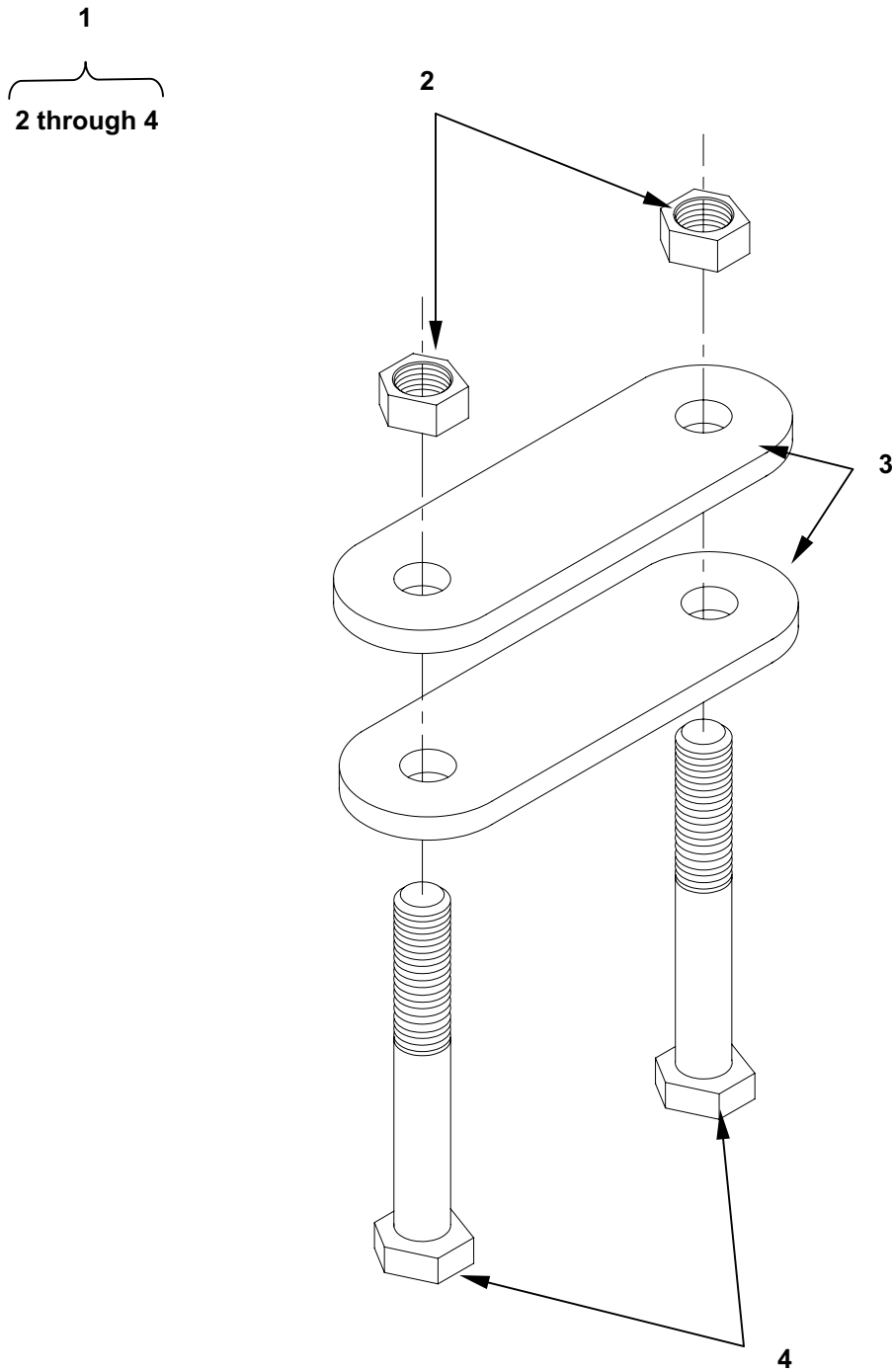


Figure 6. Connector Latch Assembly

**GROUP 0204 CONNECTOR LATCH ASSEMBLY  
REPAIR PARTS LIST**

(1) ITEM NO.	(2) SMR CODE	(3) NSN	(4) CAGE C	(5) PART NUMBER	(6) DESCRIPTION AND USABLE ON CODE (UOC)	(7) QTY
Group 0204, Connector Latch Assembly Figure 6, Connector Latch Assembly						
1	PAOOO	1670-01-470-8333	81337	11-1-3924	Latch Assembly, Connector	
2	XD000		80204	ANSI B18.2.2	Nut, Hex 1-12-UNF-2B, Steel, Carbon, Grade A, ASTM A563, Zinc Coat per ASTM B633, Type II, Class SC3	2
3	PAOOO	5365-01-354-8932	81337	11-1-1722	Plate, Side	2
4	PAOOO	5306-01-471-5419	81337	11-1-3910-2	Bolt, Link	2
<b>END OF FIGURE</b>						





---

GROUP 0205 COUPLING CABLE ASSEMBLY

---

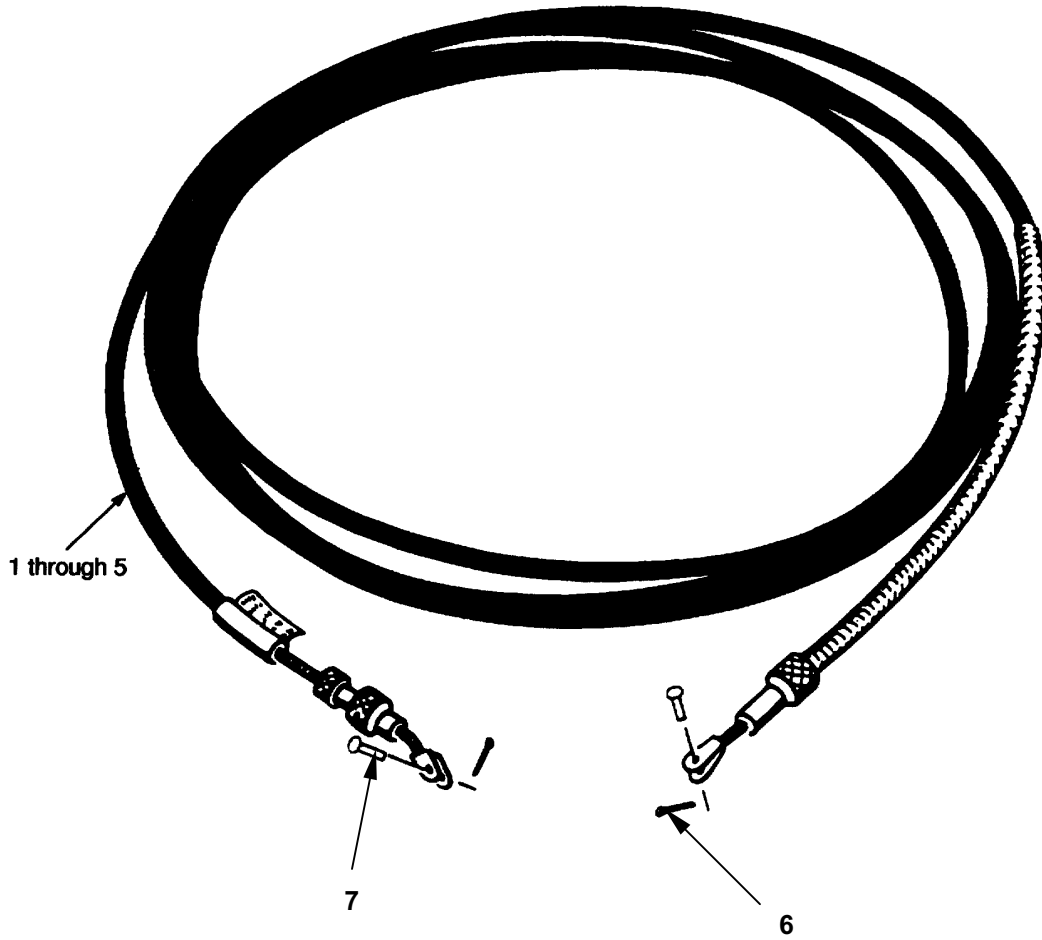


Figure 7. Coupling Cable Assembly

**GROUP 0205 COUPLING CABLE ASSEMBLY  
REPAIR PARTS LIST**

(1) ITEM NO.	(2) SMR CODE	(3) NSN	(4) CAGEC	(5) PART NUMBER	(6) DESCRIPTION AND USABLE ON CODE (UOC)	(7) QTY
Group 0205, Coupling Cable Assembly Figure 7, Coupling Cable Assembly						
1	PAOZZ	1670-00-434-5797	81337	11-1-2061-1	Cable Assembly, Coupling, 12-FT	1
2	PAOZZ	1670-00-434-5798	81337	11-1-2061-2	Cable Assembly, Coupling, 16-FT	1
3	PAOZZ	1670-00-434-5795	81337	11-1-2061-3	Cable Assembly, Coupling, 20-FT	1
4	PAOZZ	1670-00-434-5782	81337	11-1-2061-4	Cable Assembly, Coupling, 24-FT	1
5	PAOZZ	1670-00-157-6527	81337	11-1-2061-5	Cable Assembly, Coupling, 28-FT	1
6	PAOZZ	5315-00-839-2325	96906	ASME B18.8.1	Pin, Cotter	2
7	PAOOZ	5315-00-812-3766	96906	MS20392-2C15	Pin, Straight-head	2
<b>END OF FIGURE</b>						







GROUP 0206 ACTUATOR ASSEMBLY

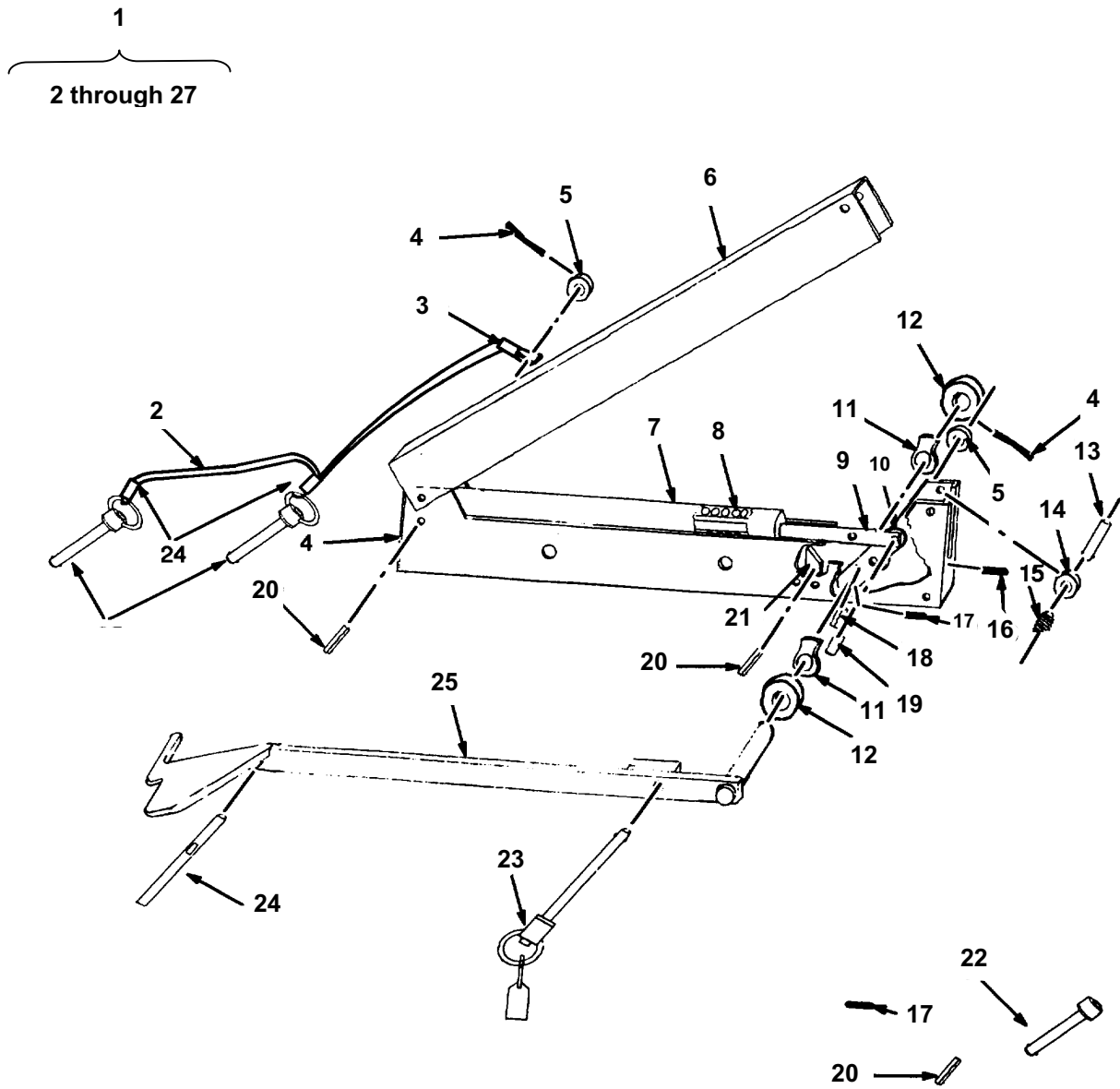


Figure 8. Actuator Assembly

**GROUP 0206 ACTUATOR ASSEMBLY  
REPAIR PARTS LIST**

(1) ITEM NO.	(2) SMR CODE	(3) NSN	(4) CAGEC	(5) PART NUMBER	(6) DESCRIPTION AND USABLE ON CODE (UOC)	(7) QTY
Group 0206, Actuator Assembly Figure 8, Actuator Assembly						
1	PAOOO	1670-01-182-1979	81337	11-1-1737	Actuator Assembly	1
2	PAOZZ	4010-01-216-6763	81349	MIL-W-5424	Cable, 7x7x <sup>1</sup> / <sub>16</sub>	1
3	PAOZZ	4030-00-452-2568	96906	MS51844-1	Swaging Sleeve, Wire	3
4	PAOZZ	5315-00-839-2325	96906	MS24665-132	Pin, Cotter	2
5	PAOZZ	5310-00-809-8546	96906	MS27183-8	Washer, Flat, <sup>7</sup> / <sub>32</sub> -IN.	2
6	XAOZZ		81337	11-1-1745	Cover, Housing	1
7	XAOZZ		81337	11-1-1739	Shell, Spring	1
8	PAOZZ	5360-01-320-0999	81337	11-1-1747	Spring, Helical, Compressed	1
9	PAOZZ	1670-01-315-7001	81337	11-1-1738	Rod, Spring Guide	1
10	XAOZZ		81337	11-1-1741	Actuator, Cable	1
11	XAOZZ		81337	11-1-1743	Cam, Locking	2
12	XAOZZ		81337	11-1-1744	Spacer	2
13	PAOZZ	5315-01-318-6886	81337	11-1-1750	Pin, Shoulder, Headless	1
14	PAOZZ	5365-01-320-8511	81337	11-1-1752	Ring, Retaining	1
15	PAOZZ	5360-01-322-3607	81337	11-1-1751	Spring, Helical, Compressed	1
16	PAOZZ	5315-00-058-9765	96906	MS16562-230	Pin, Spring	1
17	PAOZZ	5315-01-312-1188	96906	MS35675-26	Pin, Grooved, Headless	2
18	PAOZZ	5315-01-134-9400	96906	MS35678-30	Pin, Grooved, Headless	1
19	PAOZZ	5315-00-990-1338	96906	MS20392-2C19	Pin, Straight, Headless	1

---

**GROUP 0206 ACTUATOR ASSEMBLY  
REPAIR PARTS LIST**


---

(1) ITEM NO.	(2) SMR CODE	(3) NSN	(4) CAGEC	(5) PART NUMBER	(6) DESCRIPTION AND USABLE ON CODE (UOC)	(7) QTY
20	PAOZZ	5315-00-200-3183	96906	MS16562-240	Pin, Spring	3
21	XAOZZ		81337	11-1-1742	Block, Stop	1
22	PAOZZ	5315-00-812-3752	96906	MS20392-2C57	Pin, Straight, Headed	1
23	PAOZZ	5315-00-166-5441	81337	11-1-1749	Pin, Wire, Locking	1
24	PAOZZ	5315-01-357-8453	81337	11-1-1753	Pin, Shoulder, Headless	1
25	XAOZZ		81337	11-1-1746	Arm, Actuator	1
26	XAOZZ		81337	11-1-1740	Housing, Actuator	1
27	PAOZZ	5315-00-702-1301	96906	MS17985-620	Pin, Quick-Release	2
<b>END OF FIGURE</b>						



GROUP 03 M-1 CARGO PARACHUTE RELEASE

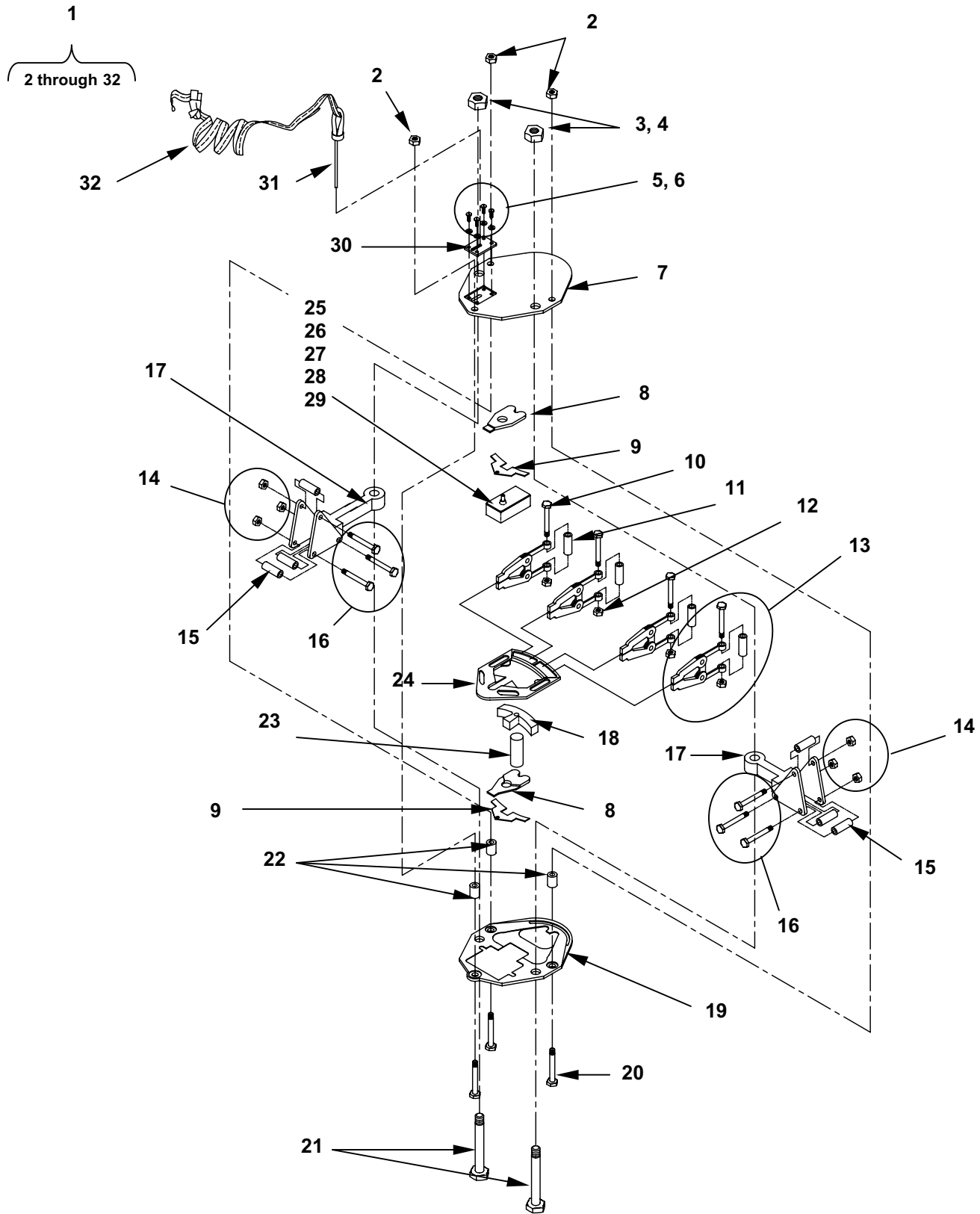


Figure 9. M-1 Cargo Parachute Release

**GROUP 03 M-1 CARGO PARACHUTE RELEASE  
REPAIR PARTS LIST**

(1) ITEM NO.	(2) SMR CODE	(3) NSN	(4) CAGEC	(5) PART NUMBER	(6) DESCRIPTION AND USABLE ON CODE (UOC)	(7) QTY
Group 03, M-1 Cargo Parachute Release Figure 9, M-1 Cargo Parachute Release						
1	PAOOO	1670-01-097-8816	81337	11-1-1487-2	Release, Cargo Parachute, M-1	1
2	PAOZZ	5310-00-926-1852	96906	MS21083N6	Nut, Self-Locking	3
3	PAOZZ	5310-01-408-2779	80205	NAS1149F1063P	Washer, Flat .640 ID, .063 THK	2
4	PAOZZ	5310-00-925-9642	81337	MS21083N10	Nut, Self-Locking	6
5	PAOZZ	5305-00-957-7811	96906	MS24693S272	Screw, Machine	4
6	XDOZZ		96906	MS35790N17	Washer, Lock	4
7	XAOZZ		81337	11-1-1500	Plate, Front	1
8	XAOZZ		81337	11-1-1491	Toggle, M-1	2
9	PAOZZ	5325-01-087-1605	81337	11-1-1492	Slide, Toggle Lock	2
10	PBOZZ	5306-00-451-1136	81337	11-1-3904-1	Bolt, Connector	3
11	PAOZZ	5365-00-139-4990	81337	11-1-3905-1	Sleeve, Connector	3
12	PAOZZ	5310-00-943-9897	96906	MS21083N9	Nut, Self-Locking	3
13	PAOOO	1670-00-400-2771	81337	11-1-3718-1	Connector, Assembly	3
14	PAOZZ	5310-00-925-9642	96906	MS21083N10	Nut, Self-Locking	6
15	PAOZZ	5365-00-451-8290	81337	11-1-1499	Spacer, Load Suspension	4
16	XDOZZ		81337	11-1-3907-1	Bolt, Machine, .625-18UNF .3A	6
17	XAOZZ		81337	11-1-1497	Link, Suspension, Lower	2
18	PAOZZ	1670-01-087-1604	81337	11-1-1490	Clamp, Retainer	1
19	XAOZZ		81337	11-1-1489	Plate, Back	1
20	PAOZZ	5306-00-207-8362	88044	11-1-4100	Bolt, Machine	3
21	XDOZZ		81337	11-1-3907-1	Bolt, Machine, .625-18UNF-3A	6
22	XAOZZ		81337	11-1-1494	Spacer	3

---

**GROUP 03 M-1 CARGO PARACHUTE RELEASE  
REPAIR PARTS LIST**


---

(1) ITEM NO.	(2) SMR CODE	(3) NSN	(4) CAGEC	(5) PART NUMBER	(6) DESCRIPTION AND USABLE ON CODE (UOC)	(7) QTY
23	XAOZZ		81337	11-1-1495	Shaft, Straight Toggle	1
24	XAOZZ		81337	11-1-1488	Link, Suspension, Upper	1
25	PAOOO	1670-00-400-2772	81337	11-1-894-1	Timer Delay Assembly	1
26	PAOZZ	6645-01-108-3457	81337	11-1-2614-1	Time Movement, Mechanical	1
27	PAOZZ	5315-01-102-8755	81337	11-1-2671	Key, Short	1
28	PAOZZ	5315-01-102-8754	81337	11-1-2670	Key, Long	1
29	PAOZZ	1670-01-102-8753	81337	11-1-2669	Toggle, Timer, Delay	1
30	XAOZZ		81337	11-1-1496	Guide, Arming Wire	1
31	PAOZZ	4010-00-431-8490	81337	11-1-493	Wire, Arming	1
32	MOOZZ		81337	11-1-488	Lanyard, Arming Wire	1
<b>END OF FIGURE</b>						





GROUP 0301 PARACHUTE CONNECTOR

1  
2 through 7

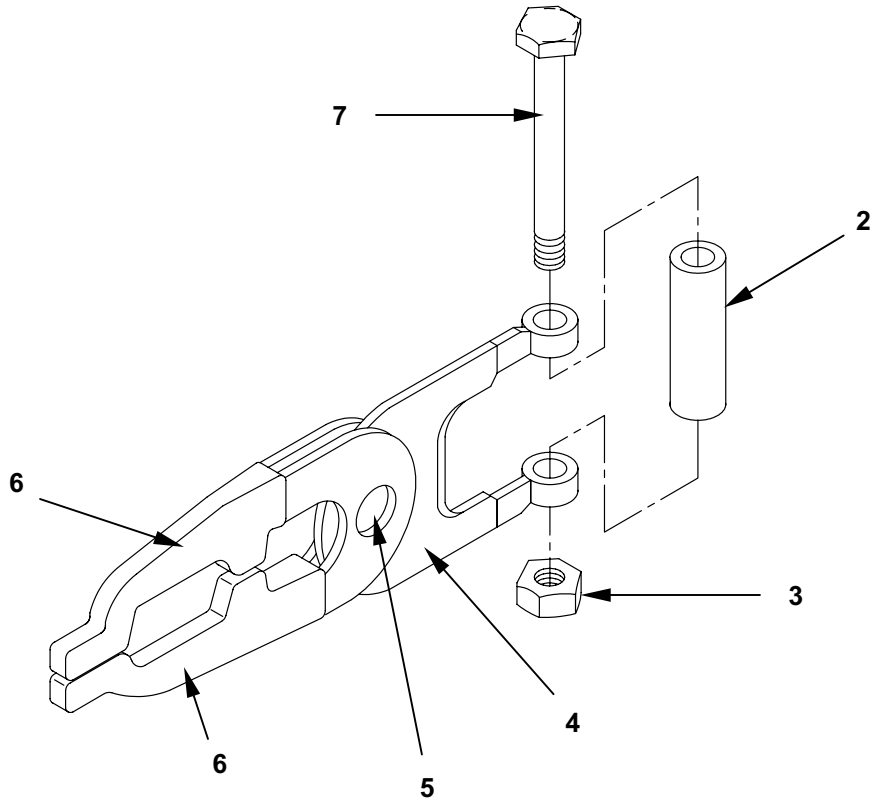


Figure 10. Parachute Connector

**GROUP 0301 PARACHUTE CONNECTOR  
REPAIR PARTS LIST**

(1) ITEM NO.	(2) SMR CODE	(3) NSN	(4) CAGEC	(5) PART NUMBER	(6) DESCRIPTION AND USABLE ON CODE (UOC)	(7) QTY
Group 0301, Parachute Connector Figure 10, Parachute Connector						
1	PAOZZ	1670-00-400-2771	81337	11-1-3718-1	Connector, Assembly	V
2	PAOZZ	5365-00-139-4990	81337	11-1-3905-1	Sleeve, Connector	1
3	PAOZZ	5310-00-943-9897	81337	MS21083N9	Nut, Self Locking, Hex, .562-18UNJF	
4	XAOZZ		81337	11-1-3719-1		Connector Body
5	XAOZZ		81337	11-1-3721-1	Pin, Connector	1
6	XAOZZ		81337	11-1-3720-1	Connector, Arm	2
7	PAOZZ	5306-00-451-1136	81337	11-1-3904-1	Bolt, Connector	1
<b>END OF FIGURE</b>						





GROUP 0302 TIMER DELAY ASSEMBLY

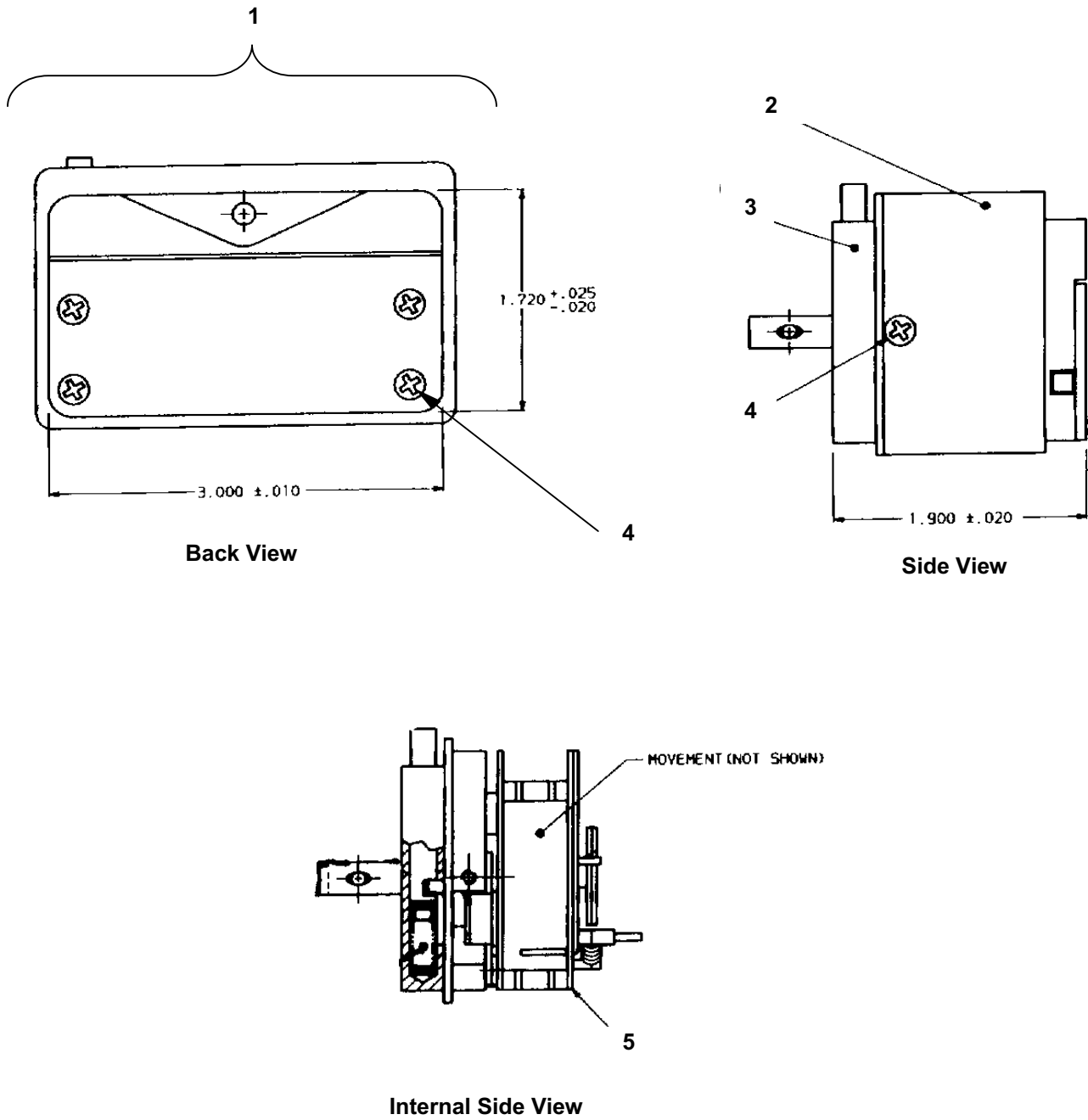


Figure 11. Timer Delay Assembly

**GROUP 0302 TIMER DELAY ASSEMBLY  
REPAIR PARTS LIST**

(1) ITEM NO.	(2) SMR CODE	(3) NSN	(4) CAGEC	(5) PART NUMBER	(6) DESCRIPTION AND USABLE ON CODE (UOC)	(7) QTY
Group 0302, Timer Delay Assembly Figure 11, Timer Delay Assembly						
1	PAOZZ	1670-00-400-2772	81337	11-1-894-1	Timer Delay Assembly	1
2	XAOZZ		81337	11-1-2666	Housing Assembly	1
3	PAOZZ	1670-01-098-4189	81337	11-1-2660	Mounting Block Assembly	1
4	XAOZZ		80204	ANSI B18.6.3	Screw, Machine, Countersunk, Type I, .112-40X.25L	6
5	PAOZZ	6645-01-017-9534	81337	11-1-2614-1	Timer and Stem Assembly	1
<b>END OF FIGURE</b>						







GROUP 04 M-2 CARGO PARACHUTE RELEASE

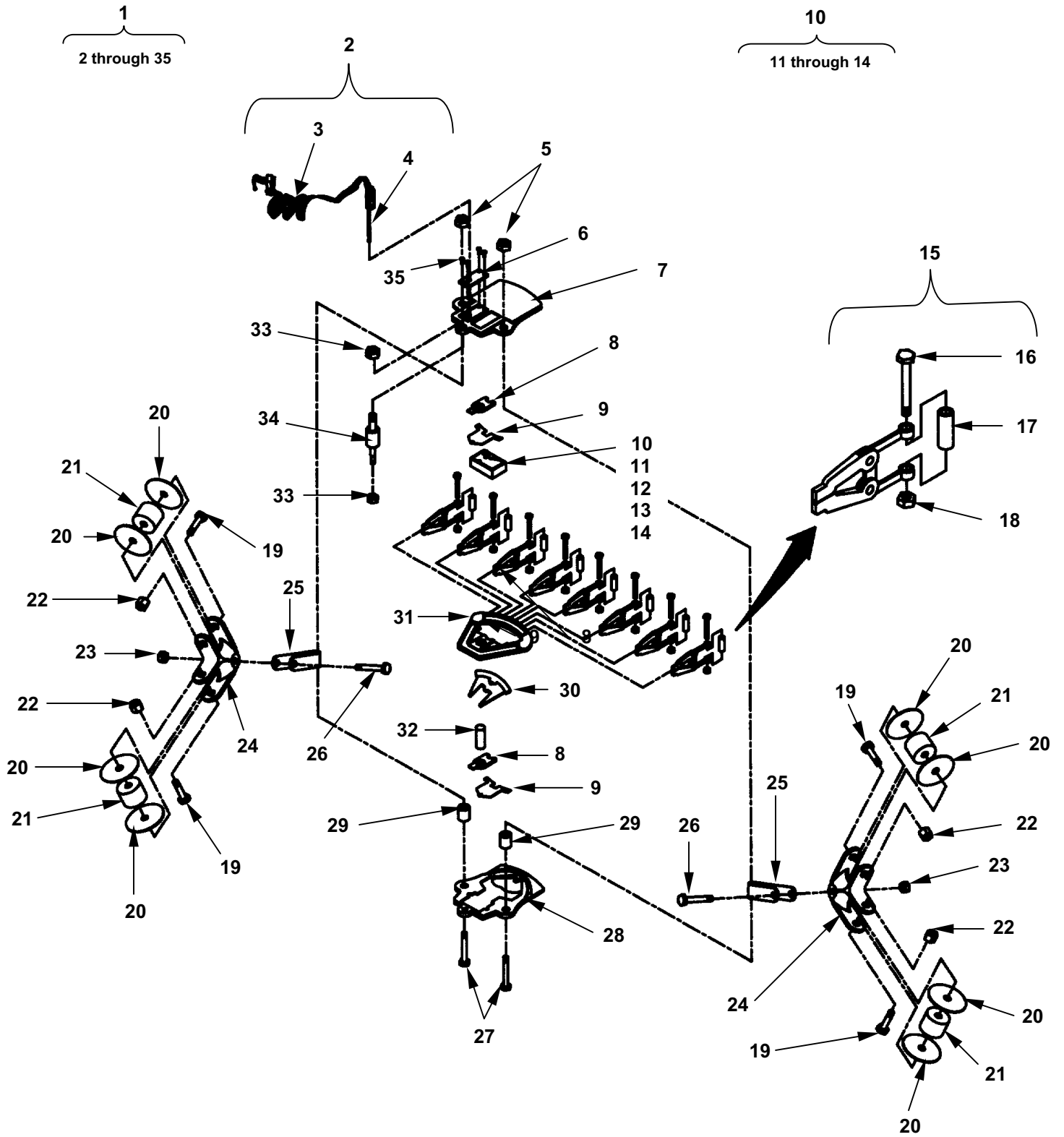


Figure 12. M-2 Cargo Parachute Release

**GROUP 04 M-2 CARGO PARACHUTE RELEASE  
REPAIR PARTS LIST**

(1) ITEM NO.	(2) SMR CODE	(3) NSN	(4) CAGEC	(5) PART NUMBER	(6) DESCRIPTION AND USABLE ON CODE (UOC)	(7) QTY
Group 04, M-2 Cargo Parachute Release Figure 12, M-2 Cargo Parachute Release						
1	PAOOO	1670-01-097-8817	81337	11-1-565-2	Release, Cargo Parachute, M-2	1
2	XCOZZ		81337	11-1-487	Lanyard & Arming Wire	1
3	MOOZZ		81337	11-1-488	Lanyard, Arming Wire	1
4	PAOZZ	4010-00-431-8490	81337	11-1-493	Wire, Arming	1
5	PAOZZ	5310-00-982-6809	96906	MS21044N10	Nut, Self-Locking	2
6	XDOZZ		81337	11-1-899	Guide, Arming Wire	1
7	XAOZZ		81337	11-1-513	Plate, Front	1
8	PAOZZ	1670-01-315-4562	81337	11-1-511	Toggle	2
9	PAOZZ	1670-01-307-0534	81337	11-1-567	Slide, Toggle Lock	2
10	PAOOO	1670-00-400-2772	81337	11-1-894-1	Timer Delay Assembly	1
11	PAOZZ	6645-01-108-3457	81337	11-1-2614-1	Timing Movement, Mechanical	1
12	PAOZZ	5315-01-102-8755	81337	11-1-2671	Key, Short	1
13	PAOZZ	5315-01-102-8754	81337	11-1-2670	Key, Machine, Long	1
14	PAOZZ	1670-01-102-8753	81337	11-1-2669	Toggle	1
15	PAOOO	1670-00-400-2771	81337	11-1-3718-1	Connector, Parachute	8
16	PAOZZ	5306-00-451-1136	81337	11-1-3904-1	Bolt, Connector	8
17	PAOZZ	5365-00-139-4990	96906	11-1-3905-1	Sleeve, Connector	8
18	PAOZZ	5310-00-943-9897	81337	MS21083N9	Nut, Self-Locking	8
19	PAOZZ	5306-01-320-1048	81337	11-1-3515	Bolt, Shoulder	4
20	PAOZZ	1670-01-333-1748	81337	11-1-3725	Guide, Sling	8
21	PAOZZ	5365-00-451-8290	81337	11-1-1499	Spacer, Sleeve	4

**GROUP 04 M-2 CARGO PARACHUTE RELEASE  
REPAIR PARTS LIST**

(1) ITEM NO.	(2) SMR CODE	(3) NSN	(4) CAGEC	(5) PART NUMBER	(6) DESCRIPTION AND USABLE ON CODE (UOC)	(7) QTY
22	PAOZZ	5365-01-321-2530	81337	11-1-3723	Sleeve, Suspension, Lower Link	
23	PAOZZ	5310-00-943-9897	96906	MS21083N9	Nut, Self-Locking	2
24	XAOZZ		81337	11-1-478	Link, Suspension, Lower	2
25	PAOZZ	5340-01-323-5678	81337	11-1-491	Clevis, Suspension Link	2
26	PAOZZ	5306-00-451-1138	81337	11-1-490	Bolt, Clevis	2
27	PAOZZ	5306-01-318-9533	81337	11-1-3514	Bolt, Sleeve, Clevis	2
28	XAOZZ		81337	11-1-566	Back, Plate	1
29	PAOZZ	5365-01-321-0603	81337	11-1-3441	Sleeve, Clevis	2
30	PAOZZ	5340-01-310-2323	81337	11-1-512	Clamp, Retaining	1
31	XAOZZ		81337	11-1-477	Link, Suspension, Upper	1
32	PAOZZ	3040-01-313-8016	81337	11-1-3724	Shaft, Straight, Toggle	1
33	PAOZZ	5310-00-920-9369	96906	MS21083N8	Nut, Self-Locking	2
34	PAOZZ	5307-01-320-7260	81337	11-1-562	Stud, Shouldered	1
35	PAOZZ	5305-00-983-7428	96906	ASME/ANSI B18.3	Screw, Cap	4
<b>END OF FIGURE</b>						



GROUP 0401 PARACHUTE CONNECTOR

1  
2 through 7

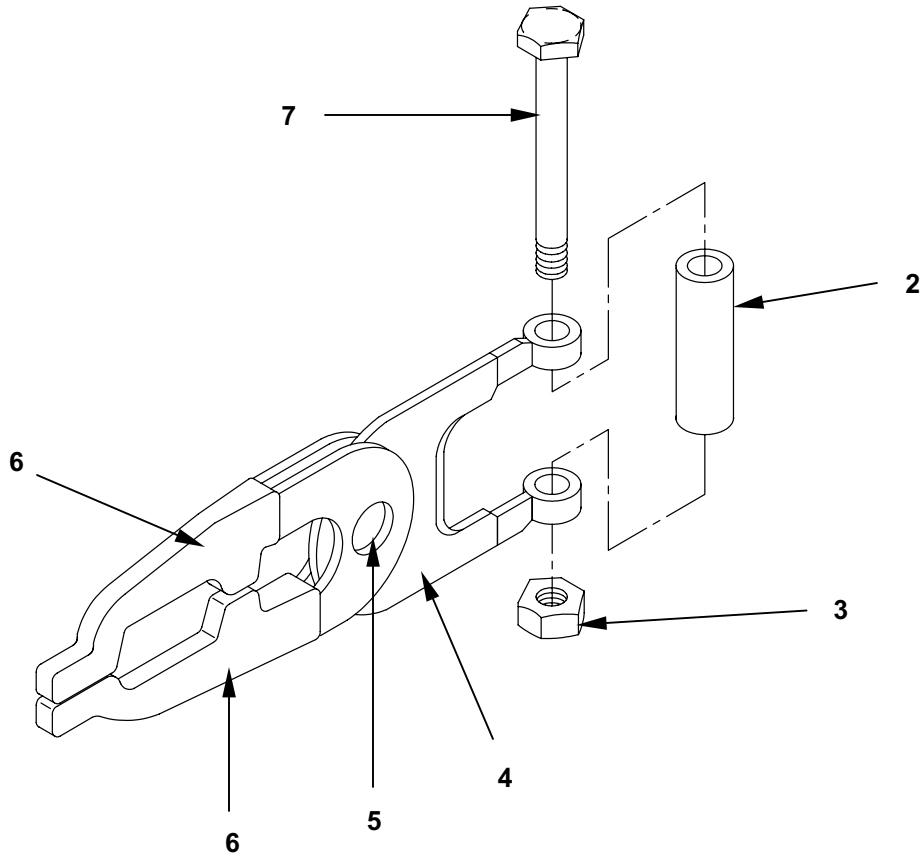


Figure 13. Parachute Connector

**GROUP 0301 PARACHUTE CONNECTOR  
REPAIR PARTS LIST**

(1) ITEM NO.	(2) SMR CODE	(3) NSN	(4) CAGEC	(5) PART NUMBER	(6) DESCRIPTION AND USABLE ON CODE (UOC)	(7) QTY
Group 0401, Parachute Connector Figure 13, Parachute Connector						
1	PAOZZ	1670-00-400-2771	81337	11-1-3718-1	Connector, Assembly	V
2	XAOZZ		81337	11-1-3905-1	Sleeve, Connector	1
3	PAOZZ	5310-00-943-9897	81337	MS21083N9	Nut, Self Locking, Hex, .562-18UNJF	
4	XAOZZ		81337	11-1-3719-1	Connector Body	1
5	XAOZZ		81337	11-1-3721-1	Pin, Connector	1
6	XAOZZ		81337	11-1-3720-1	Connector, Arm	2
7	XAOZZ		81337	11-1-3904-1	Bolt, Connector	1
<b>END OF FIGURE</b>						







GROUP 0402 TIMER DELAY ASSEMBLY

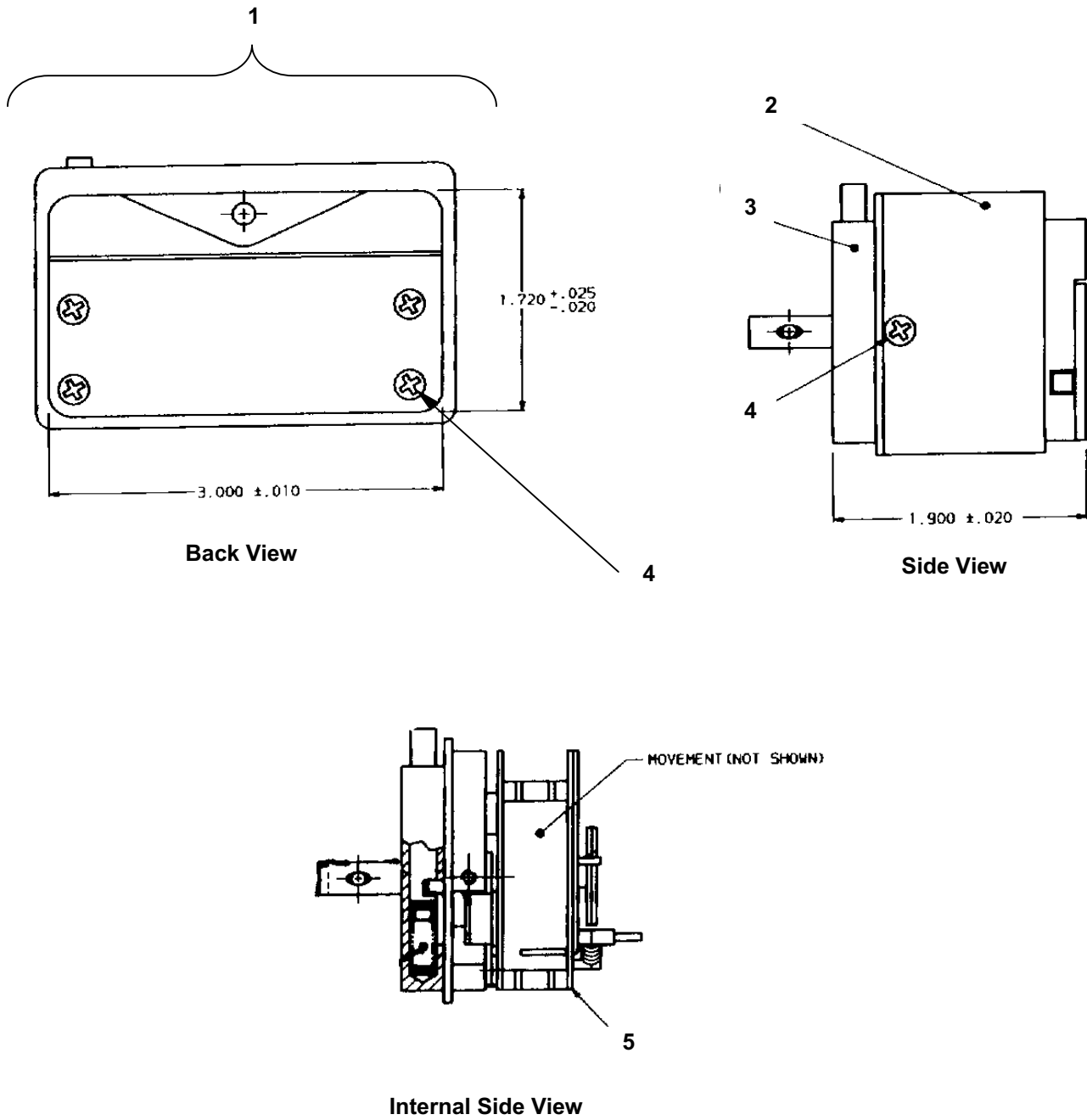


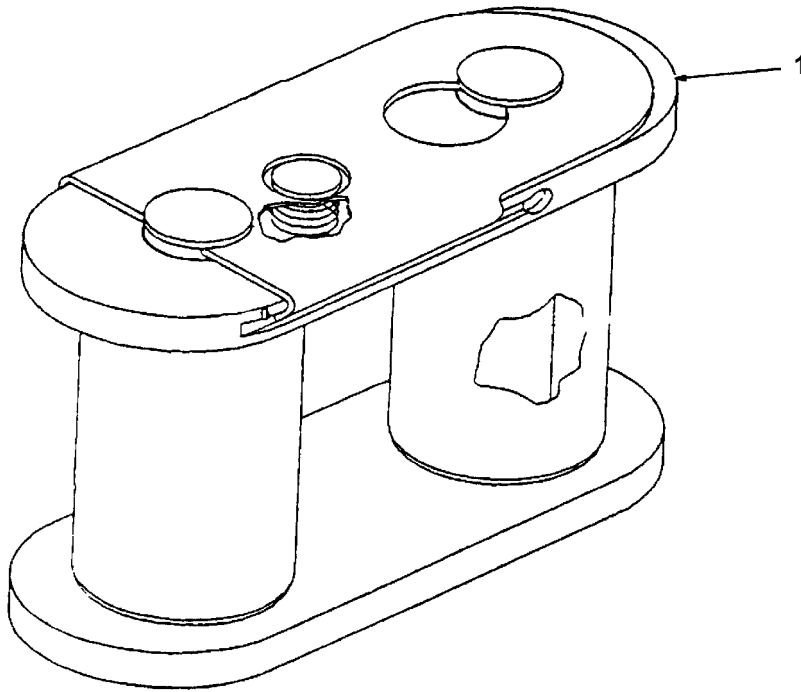
Figure 14. Timer Delay Assembly

**GROUP 0402 TIMER DELAY ASSEMBLY  
REPAIR PARTS LIST**

(1) ITEM NO.	(2) SMR CODE	(3) NSN	(4) CAGEC	(5) PART NUMBER	(6) DESCRIPTION AND USABLE ON CODE (UOC)	(7) QTY
Group 0402, Timer Delay Assembly Figure 14, Timer Delay Assembly						
1	PAOZZ	1670-00-400-2772	81337	11-1-894-1	Timer Delay Assembly	1
2	XAOZZ		81337	11-1-2666	Housing Assembly	1
3	PAOZZ	1670-01-098-4189	81337	11-1-2660	Mounting Block Assembly	1
4	XAOZZ		81337	ANSI B18.6.3	Screw, Machine, Countersunk, Type I, .112-40X.25L	6
5	PAOZZ	6645-01-017-9534	81337	11-1-2614	Timer and Stem Assembly	1
<b>END OF FIGURE</b>						



**GROUP 05 TYPE IV SINGLE SUSPENSION LINK ASSEMBLY**



**Figure 15. Type IV Single Suspension Link Assembly**

(1) ITEM NO.	(2) SMR CODE	(3) NSN	(4) CAGEC	(5) PART NUMBER	(6) DESCRIPTION AND USABLE ON CODE (UOC)	(7) QTY
Group 05, Type IV Single Suspension Link Assembly Figure 15, Type IV Single Suspension Link Assembly						
1	PAOZZ	1670-00-783-5988	81337	11-1-3359	Link Assembly, Single Suspension, Type IV	AR
<b>END OF FIGURE</b>						





GROUP 0501 HEAVY-DUTY LINK ASSEMBLY

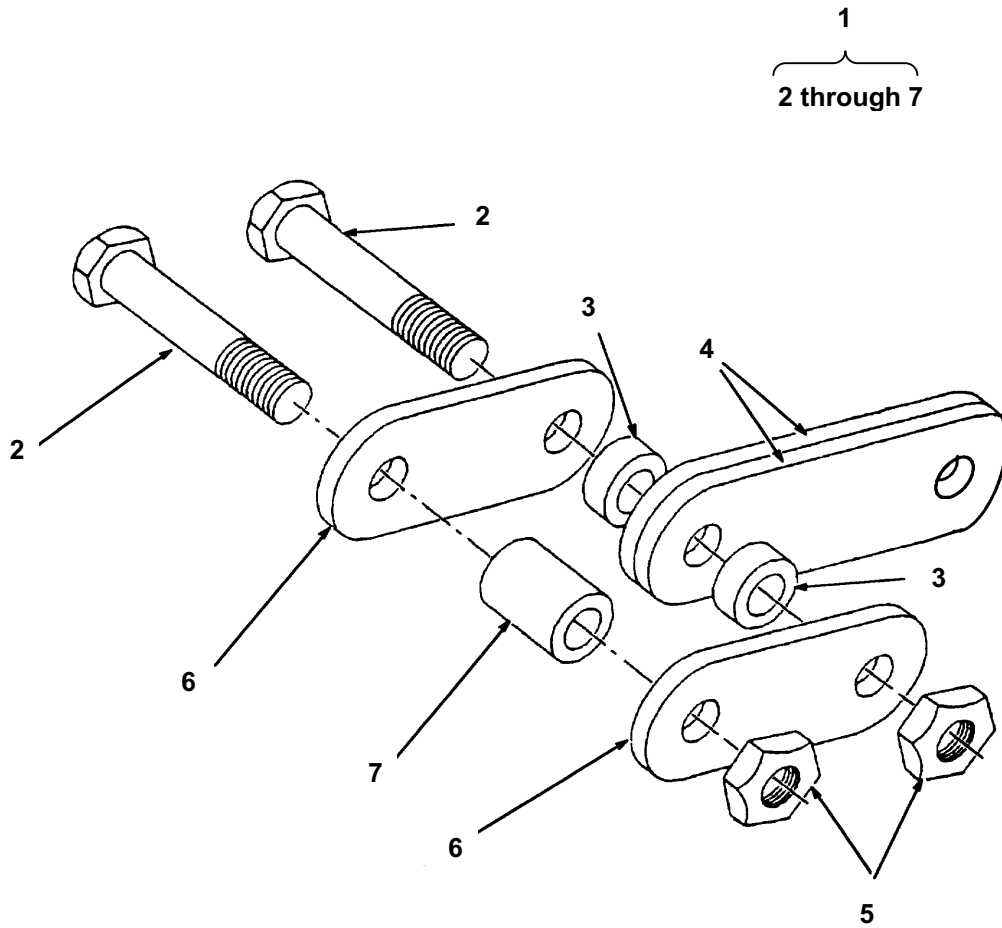


Figure 16. Heavy-Duty Link Assembly



**GROUP 0501 HEAVY-DUTY LINK ASSEMBLY  
REPAIR PARTS LIST**

(1) ITEM NO.	(2) SMR CODE	(3) NSN	(4) CAGEC	(5) PART NUMBER	(6) DESCRIPTION AND USABLE ON CODE (UOC)	(7) QT Y
Group 0501, Heavy-Duty Link Assembly Figure 16, Heavy-Duty Link Assembly						
1	AOOZZ		81337	68B1883	Link Assembly, Heavy-Duty	AR
2	PAOZZ	5306-00-435-8994	88044	AN17-36A	Bolt, Machine, 1-IN., 12-NF	2
3	PAOZZ	5365-00-005-1577	98750	66B1887	Spacer, Sleeve, Small	2
4	PAOZZ	1670-00-003-1954	81337	66B1883-2	Slide Plate, 5 ½-IN.	2
5	PAOZZ	5310-00-232-5165	81352	AN315-15R	Nut, Plain, Hex, 1-IN., 12-NF	2
6	PAOZZ	1670-00-003-1953	81337	66B1883-1	Slide Plate, 3 ¾-IN.	2
7	PAOZZ	5365-00-007-3414	98750	65B3650	Spacer, Sleeve, Large	2
<b>END OF FIGURE</b>						





GROUP 0502 4-POINT LINK

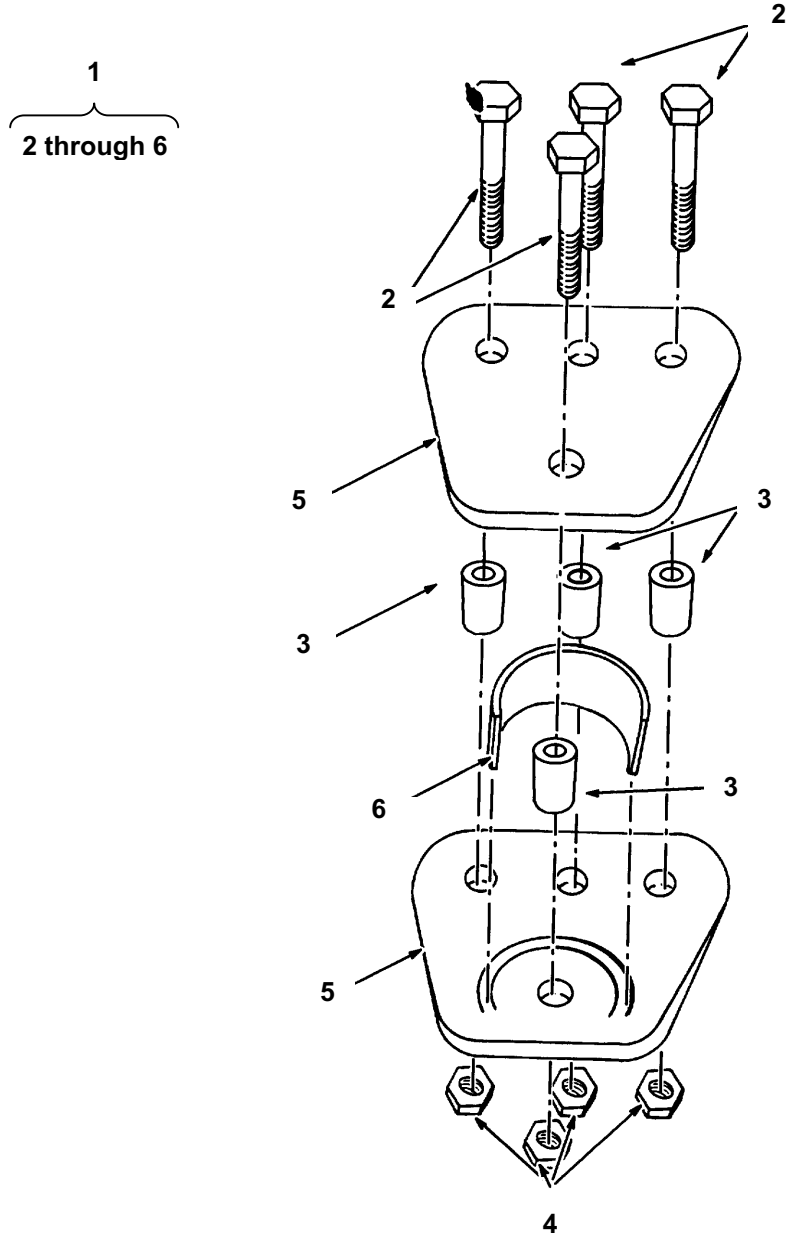


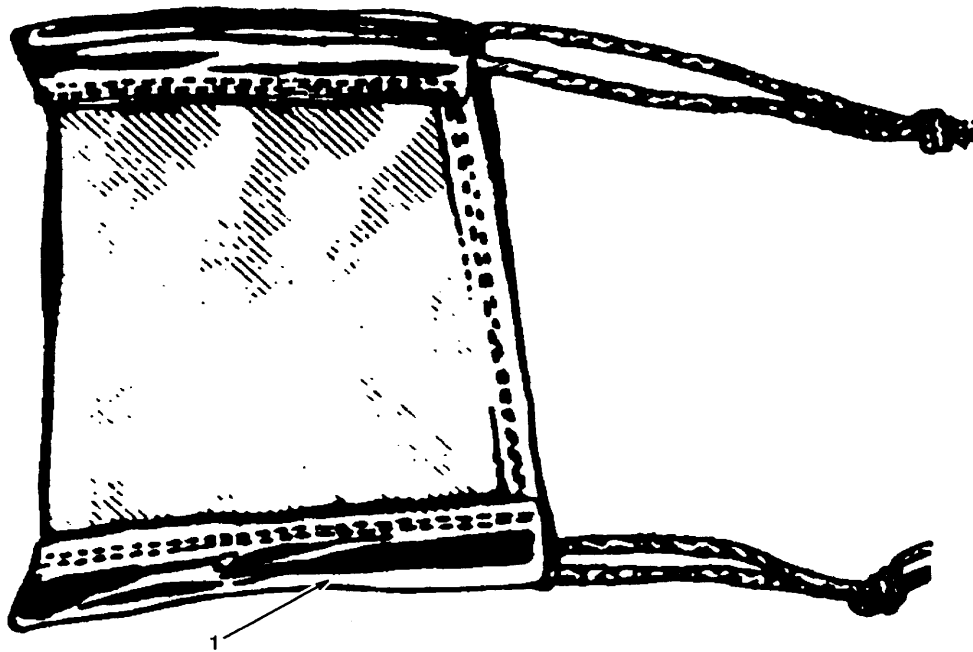
Figure 17. 4-Point Link

**GROUP 0502 4-POINT LINK  
REPAIR PARTS LIST**

(1) ITEM NO.	(2) SMR CODE	(3) NSN	(4) CAGEC	(5) PART NUMBER	(6) DESCRIPTION AND USABLE ON CODE (UOC)	(7) QTY
Group 0502, 4-Point Link Figure 17, 4-Point Link						
1	PAOOO	1670-00-006-2752	81337	65D3820	Link, 4-Point	AR
2	PAOZZ	5306-00-435-8994	81352	AN17-36A	Bolt, Machine, 1-IN., 12-NF	4
3	PAOZZ	5365-01-092-7849	81337	67B2226	Spacer, Bolt	4
4	PAOZZ	5310-00-232-5165	81352	AN315-15R	Nut, Plain, Hex, 1-IN., 12-NF	4
5	XAOZZ		81337	65D3663	Plate, Side	2
6	XAOZZ		81337	67B2211-1	Spacer, Loop	1
<b>END OF FIGURE</b>						



**GROUP 0503 TYPE IV LINK COVER**



**Figure 18. Type IV Link Cover**

(1) ITEM NO.	(2) SMR CODE	(3) NSN	(4) CAGEC	(5) PART NUMBER	(6) DESCRIPTION AND USABLE ON CODE (UOC)	(7) QTY
Group 0503, Type IV Link Cover Figure 18, Type IV Link Cover						
1	PAOZZ	1670-00-360-0329	98750	50C7496	Cover, Link, Type IV	AR
<b>END OF FIGURE</b>						







GROUP 0504 AERIAL DELIVERY CLEVIS

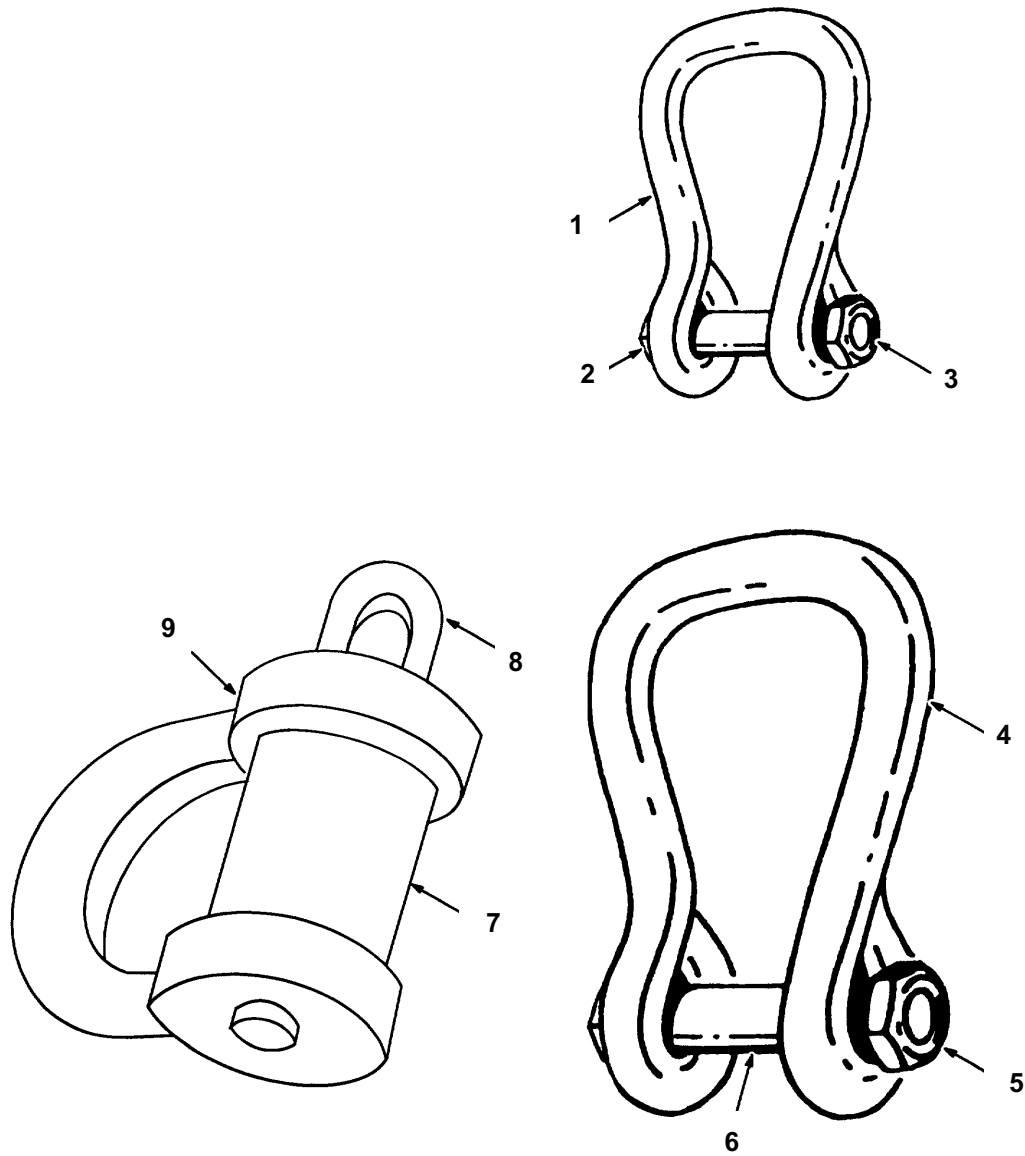


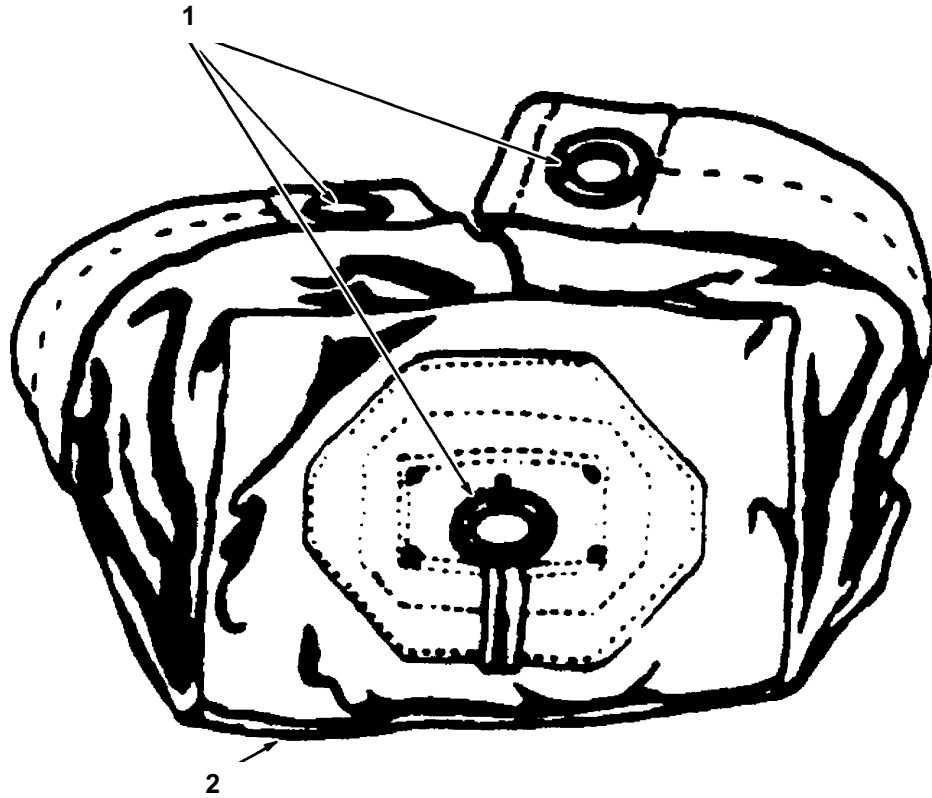
Figure 19. Aerial Delivery Clevis

**GROUP 0504 AERIAL DELIVERY CLEVIS  
REPAIR PARTS LIST**

(1) ITEM NO.	(2) SMR CODE	(3) NSN	(4) CAGE C	(5) PART NUMBER	(6) DESCRIPTION AND USABLE ON CODE (UOC)	(7) QTY
Group 0504, Aerial Delivery Clevis Figure 19, Aerial Delivery Clevis						
1	PAOZZ	4030-00-678-8562	96906	MS70087-2	Clevis, Medium, 3/4- IN.	AR
2	PAOZZ	5305-00-940-8069	80204	B1821BH075F450N	Bolt	1
3	PAOZZ	5310-00-842-1190	96906	MS35691-61	Nut	1
4	PAOZZ	4030-00-090-5354	96906	MS70087-3	Clevis, Large, 1 1/8- IN.	AR
5	PAOZZ	5310-00-891-3428	96906	MS35691-77	Nut	1
6	PAOZZ	5305-00-177-5617	80204	B1821BH100F475N	Bolt	1
7	XAOZZ		96906	MS70087-11	Sleeve	1
8	XAOZZ		96906	MS70087-10	Pin	1
9	PAOZZ	4030-00-432-2516	96906	MS70087-5	Clevis, Screw Pin, 1 1/8-IN.	AR
<b>END OF FIGURE</b>						



**GROUP 0505 CLEVIS COVER**

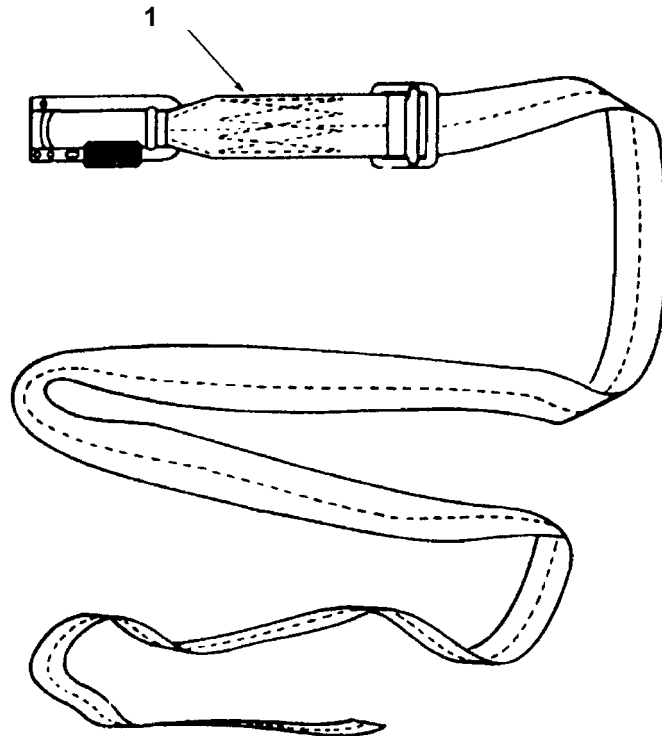


**Figure 20. Clevis Cover**

(1) ITEM NO.	(2) SMR CODE	(3) NSN	(4) CAGEC	(5) PART NUMBER	(6) DESCRIPTION AND USABLE ON CODE (UOC)	(7) QTY
Group 0505, Clevis Cover Figure 20, Clevis Cover						
1	PAOZZ	5325-01-028-0945	81349	MIL-G-16491	Grommet, Metallic	3
2	PAOZZ	1670-00-360-0328	98750	50C7406	Cover, Large Clevis	AR
<b>END OF FIGURE</b>						



**GROUP 0506 SINGLE KNIFE PARACHUTE RELEASE STRAP**



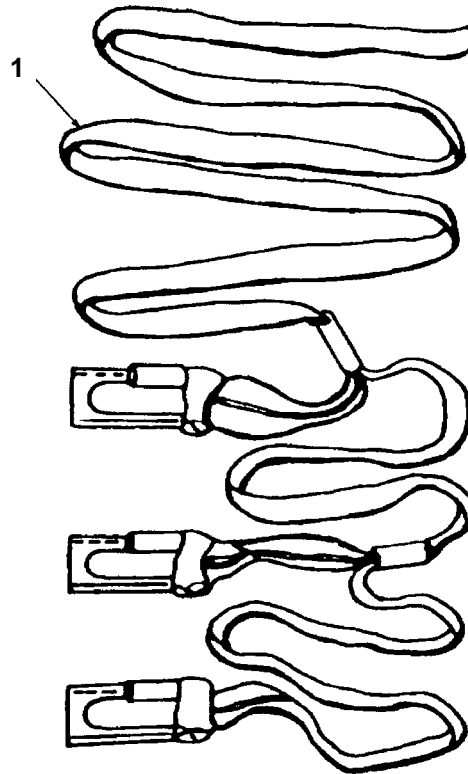
**Figure 21. Single Knife Parachute Release Strap**

(1) ITEM NO.	(2) SMR CODE	(3) NSN	(4) CAGEC	(5) PART NUMBER	(6) DESCRIPTION AND USABLE ON CODE (UOC)	(7) QTY
Group 0506, Single Knife Parachute Release Strap Figure 21, Single Knife Parachute Release Strap						
1	PAOZZ	1670-00-473-5116	81337	11-1-129	Strap, Parachute Release, Single Knife	AR
<b>END OF FIGURE</b>						





**GROUP 0507 MULTI-KNIFE PARACHUTE RELEASE STRAP**



**Figure 22. Multi-Knife Parachute Release Strap**

(1) ITEM NO.	(2) SMR CODE	(3) NSN	(4) CAGEC	(5) PART NUMBER	(6) DESCRIPTION AND USABLE ON CODE (UOC)	(7) QTY
Group 0507, Multi-Knife Parachute Release Strap Figure 22, Multi-Knife Parachute Release Strap						
1	PAOZZ	5340-00-040-8219	81337	11-1-484-2	Strap, Parachute Release, Multi-Knife	AR
<b>END OF FIGURE</b>						





GROUP 0508 3-POINT COUPLING LINK ASSEMBLY

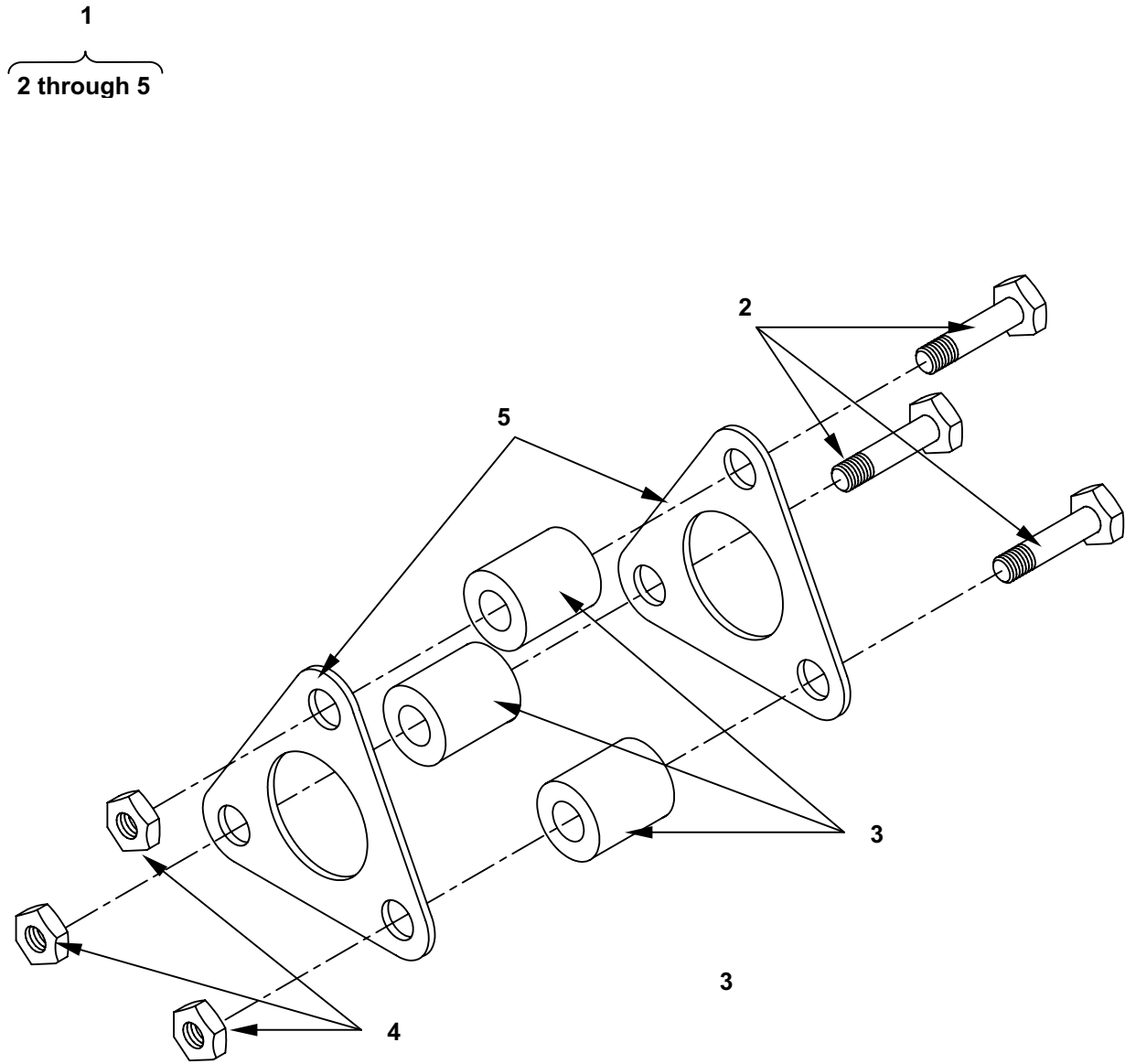


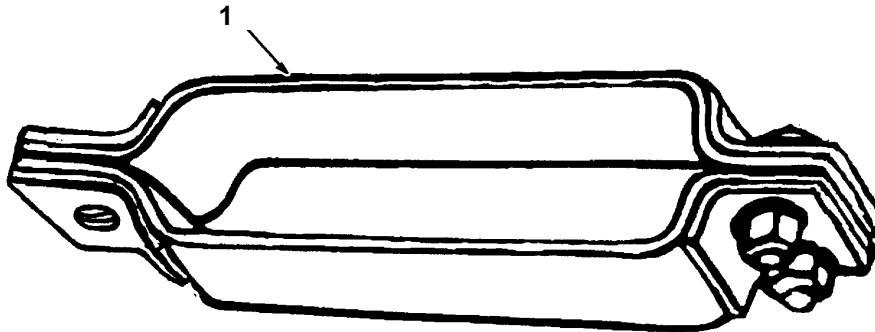
Figure 23. 3-Point Coupling Link Assembly

**GROUP 0508 3-POINT COUPLING LINK ASSEMBLY  
REPAIR PARTS LIST**

(1) ITEM NO.	(2) SMR CODE	(3) NSN	(4) CAGEC	(5) PART NUMBER	(6) DESCRIPTION AND USABLE ON CODE (UOC)	(7) QTY
Group 0508, 3-Point Coupling Link Assembly Figure 23, 3-Point Coupling Link Assembly						
1	PAOZZ	1670-01-307-0155	81337	11-1-1715-2	Link Assembly, Coupling, 3-Point	AR
2	PAOZZ	5306-01-471-5336	81337	11-1-3910-1	Screw	3
3	PAOZZ	5365-00-405-9293	81337	11-1-1718	Spacer, Bolt	3
4	PAOZZ	5310-00-776-1963	96906	MS21083-N16	Nut, Self-Locking, 1-IN., 13-UNJF-3B	3
5	XAOZZ		81337	11-1-1717	Plate, Side	2
<b>END OF FIGURE</b>						



**GROUP 0509 M-35 SUSPENSION BRACKET**



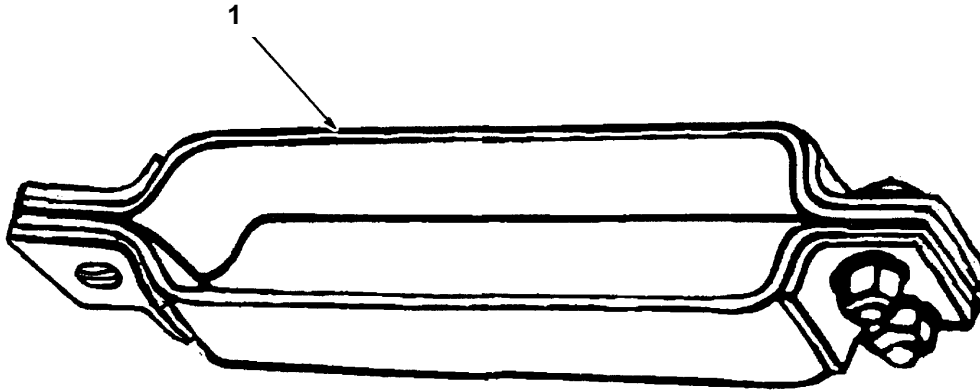
**Figure 24. M-35 Suspension Bracket**

(1) ITEM NO.	(2) SMR CODE	(3) NSN	(4) CAGEC	(5) PART NUMBER	(6) DESCRIPTION AND USABLE ON CODE (UOC)	(7) QTY
Group 0509, M-35 Suspension Bracket Figure 24, M-35 Suspension Bracket						
1	XDOZZ		81337	53C7084-1	Bracket, Suspension	AR
<b>END OF FIGURE</b>						





**GROUP 0510 M-59 Suspension Bracket**

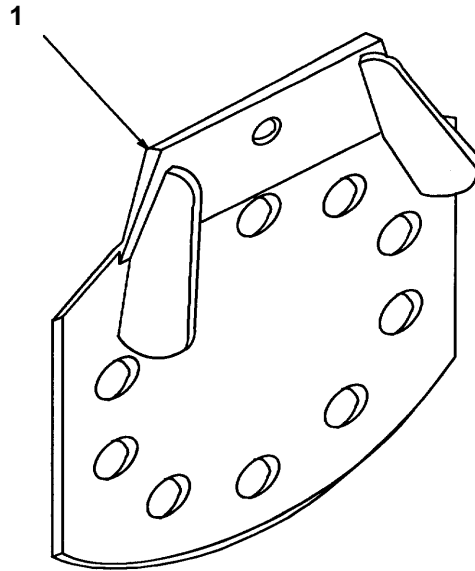


**Figure 25. M-59 Suspension Bracket**

(1) ITEM NO.	(2) SMR CODE	(3) NSN	(4) CAGEC	(5) PART NUMBER	(6) DESCRIPTION AND USABLE ON CODE (UOC)	(7) QTY
Group 0510, M-59 Suspension Bracket Figure 25, M-59 Suspension Bracket						
1	PAOZZ	1670-00-078-4319	81337	53C7084-2	Bracket, Suspension	AR
<b>END OF FIGURE</b>						



**GROUP 0511 SUSPENSION PLATE**

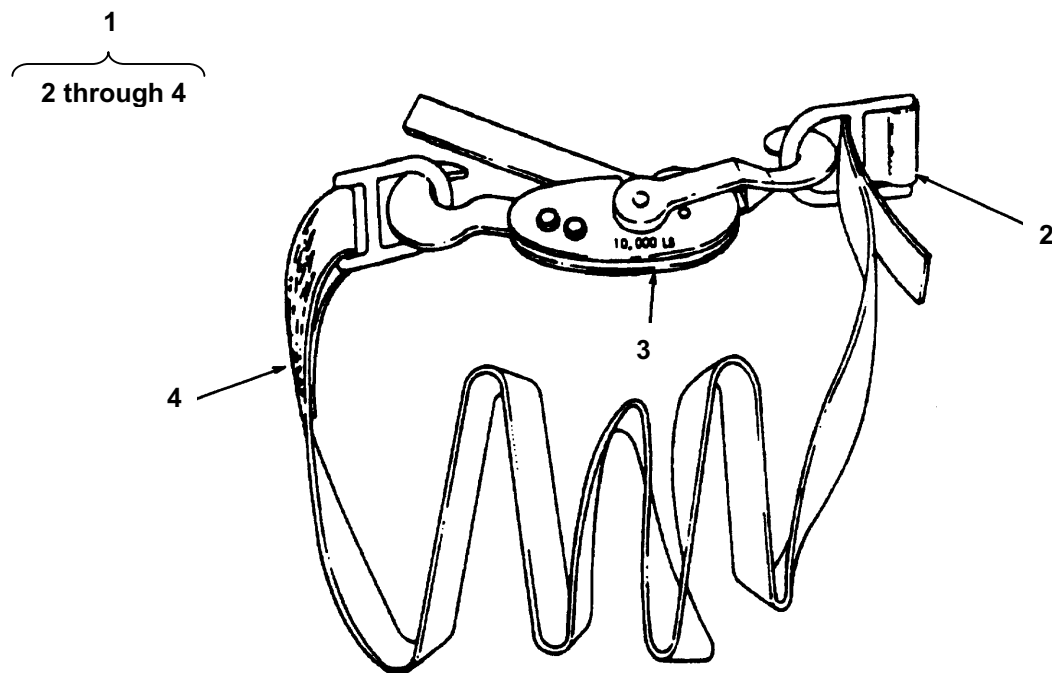


**Figure 26. Suspension Plate**

(1) ITEM NO.	(2) SMR CODE	(3) NSN	(4) CAGEC	(5) PART NUMBER	(6) DESCRIPTION AND USABLE ON CODE (UOC)	(7) QTY
Group 0511, Suspension Plate Figure 26, Suspension Plate						
1	PAOZZ	1670-01-141-1522	81337	11-1-2615	Plate, Suspension	AR
<b>END OF FIGURE</b>						



**GROUP 0512 10K CARGO TIE-DOWN**

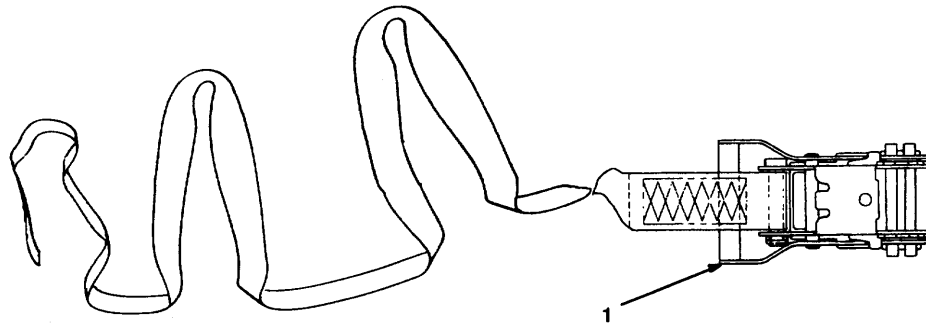


**Figure 27. 10K Cargo Tie-down**

(1) ITEM NO.	(2) SMR CODE	(3) NSN	(4) CAGEC	(5) PART NUMBER	(6) DESCRIPTION AND USABLE ON CODE (UOC)	(7) QTY
Group 0512, 10K Cargo Tie-down Figure 27, 10K Cargo Tie-down						
1	PAOZZ	1670-00-937-0271	81337	11-1-721	Tie-down, Cargo, 10K	AR
2	PAOZZ	5310-00-937-0147	96906	MS22046-8	D-Ring, Heavy-Duty	1
3	PAOZZ	3990-00-437-0292	81337	11-1-901	Binder, Load	1
4	PAOZZ	5340-00-937-0273	81337	11-1-892	Strap, Tie-down	1
<b>END OF FIGURE</b>						



**GROUP 0513 QUICK-RELEASE CARGO TIE-DOWN**



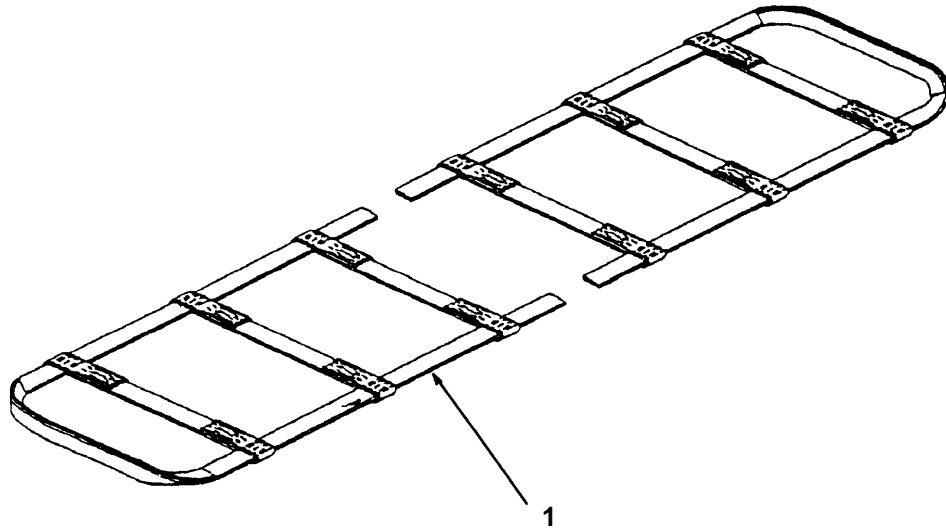
**Figure 28. Quick-Release Cargo Tie-down**

(1) ITEM NO.	(2) SMR CODE	(3) NSN	(4) CAGEC	(5) PART NUMBER	(6) DESCRIPTION AND USABLE ON CODE (UOC)	(7) QTY
Group 0513, Quick-Release Cargo Tie-down Figure 28, Quick-Release Cargo Tie-down						
1	PAOZZ	1670-01-333-6082	81337	11-1-3922	Tie-down, Cargo, Quick-Release	AR
<b>END OF FIGURE</b>						





**GROUP 0514 TYPE IV DRIVE-OFF AID**

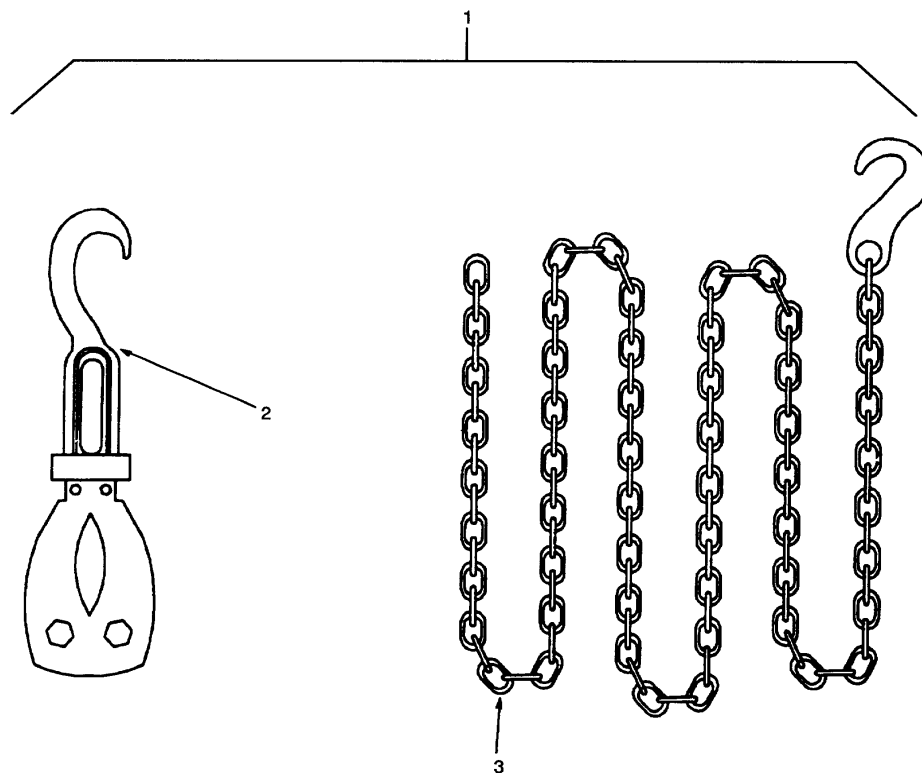


**Figure 29. Type IV Drive-Off Aid**

(1) ITEM NO.	(2) SMR CODE	(3) NSN	(4) CAGEC	(5) PART NUMBER	(6) DESCRIPTION AND USABLE ON CODE (UOC)	(7) QTY
Group 0514, Type IV Drive-Off Aid Figure 29, Type IV Drive-Off Aid						
1	PAOZZ	1670-01-344-0825	81337	11-1-3771	Drive Off Aid, Type IV	
<b>END OF FIGURE</b>						



**GROUP 0515 AIRCRAFT CARGO TIE-DOWN**



**Figure 30. Aircraft Cargo Tie-down**

(1) ITEM NO.	(2) SMR CODE	(3) NSN	(4) CAGEC	(5) PART NUMBER	(6) DESCRIPTION AND USABLE ON CODE (UOC)	(7) QTY
Group 0515, Aircraft Cargo Tie-down Figure 30, Aircraft Cargo Tie-down						
1	PAOZZ	1670-00-545-9063	81349	MIL-T-25959	Tie-down, Cargo, Aircraft	AR
2	PAOZZ	1670-01-333-6082	81337	11-1-3922	Ratchet	1
3	PAOZZ	1670-00-516-8405	81349	MIL-DTL-6458D	Chain	1
<b>END OF FIGURE</b>						





GROUP 0516 3 3/4-IN., 2-Point Link

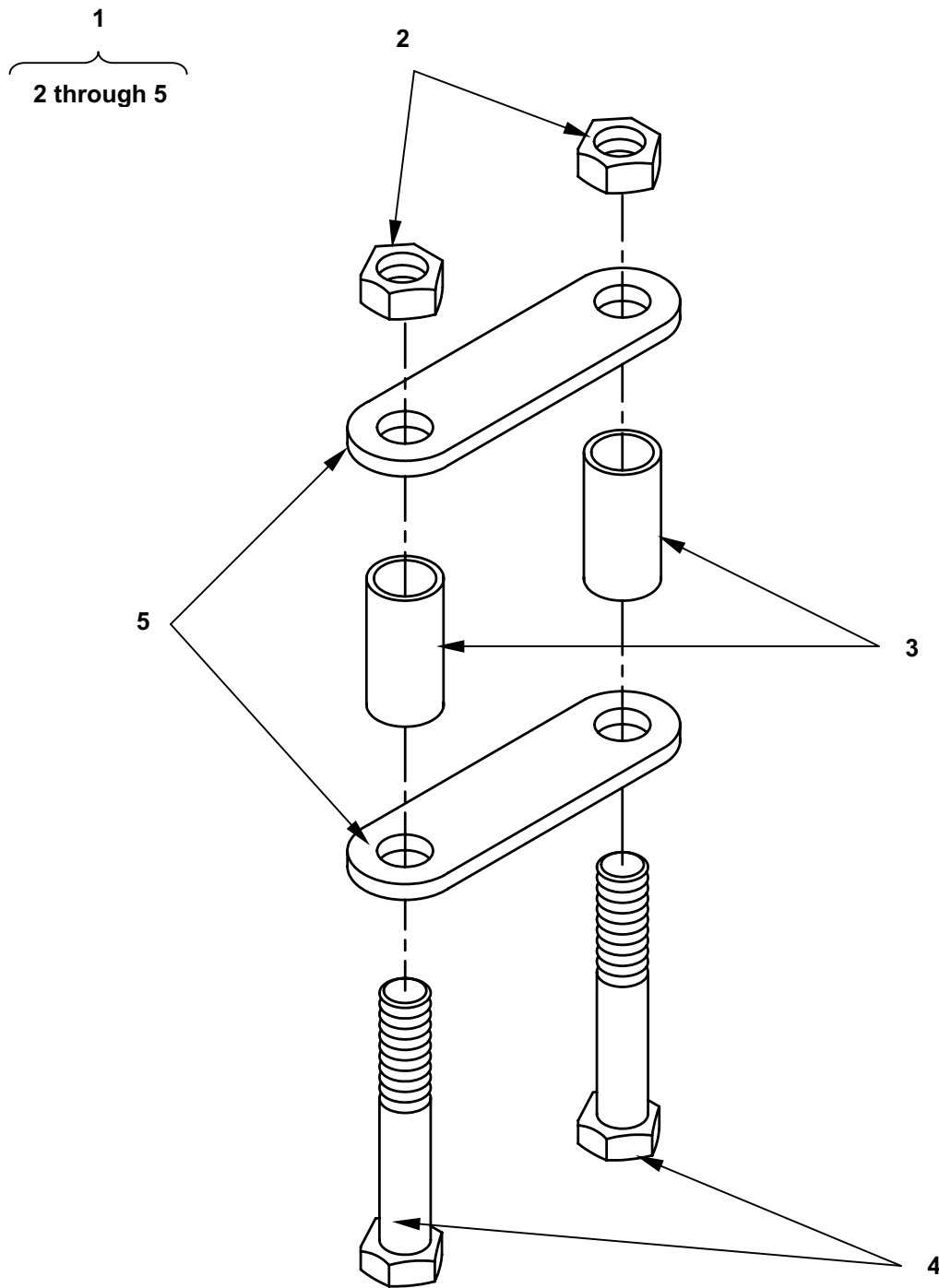


Figure 31. 3 3/4-IN., 2-Point Link

**GROUP 0516 3 3/4-IN., 2-Point Link  
REPAIR PARTS LIST**

(1) ITEM NO.	(2) SMR CODE	(3) NSN	(4) CAGEC	(5) PART NUMBER	(6) DESCRIPTION AND USABLE ON CODE (UOC)	(7) QTY
Group 0516, 3 3/4-IN., 2-Point Link Figure 31, 3 3/4-IN., 2-Point Link						
1	PAOZZ	1670-01-493-6418	81337	11-1-7026-1	Link, 2-Point, 3 3/4-IN.	1
2	PAOZZ	5310-00-232-5135	81352	AN315-15R	Nut, Plain, Hex	2
3	PAOZZ	5365-00-007-3414	98750	65B3650	Spacer, Large	2
4	PAOZZ	5306-00-435-8994	81352	AN17-36A	Bolt, Machine	2
5	PAOZZ	1670-00-003-1953	81337	66B1883-1	Plate, Clevis, 3 3/4-IN.	2
<b>END OF FIGURE</b>						







GROUP 0517 5 1/2-IN., 2-Point Link

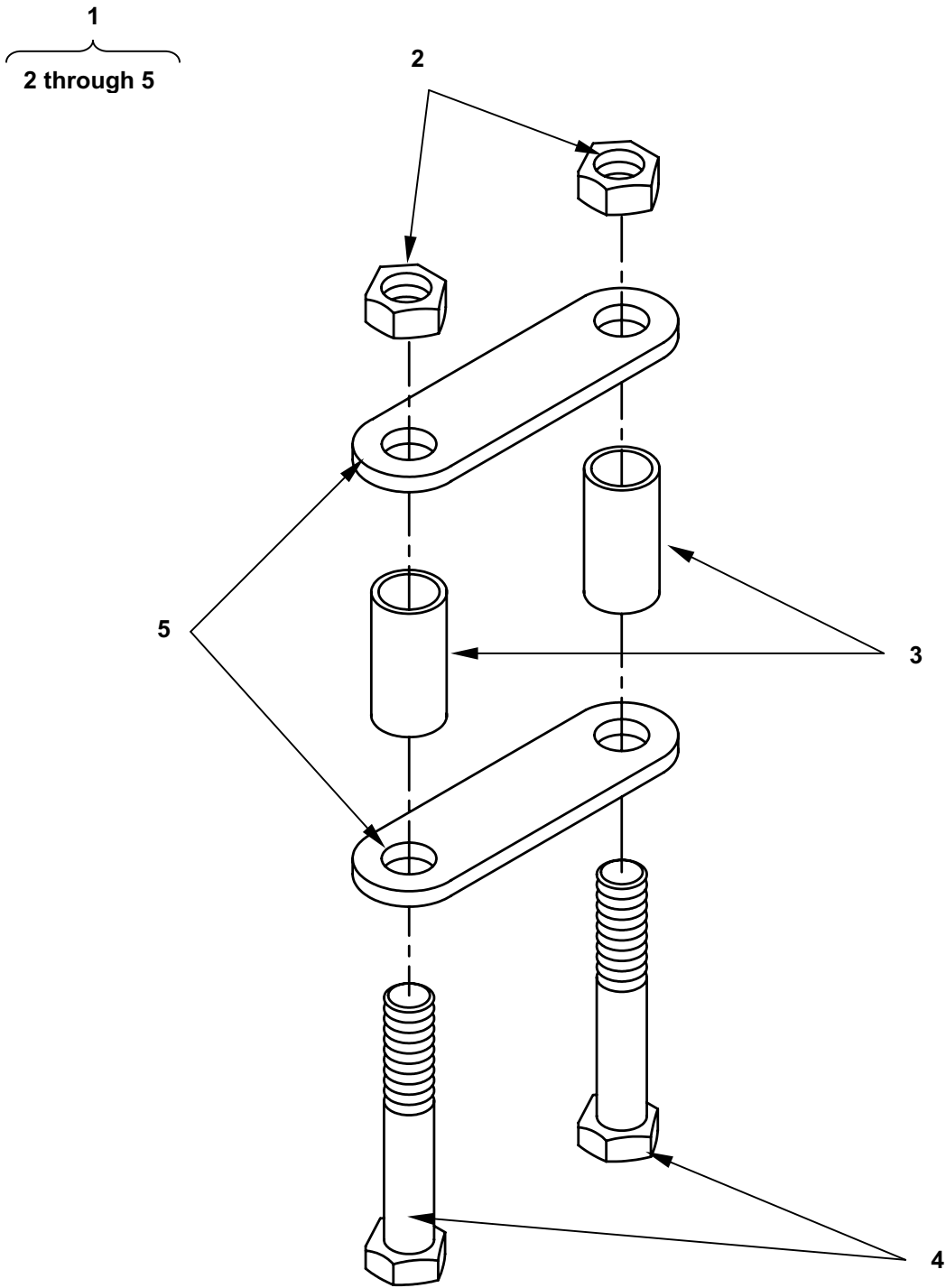


Figure 32. 5 1/2-IN., 2-Point Link

**GROUP 0517 5 ½-IN., 2-Point Link  
REPAIR PARTS LIST**

(1) ITEM NO.	(2) SMR CODE	(3) NSN	(4) CAGEC	(5) PART NUMBER	(6) DESCRIPTION AND USABLE ON CODE (UOC)	(7) QTY
Group 0517, 5 ½-IN., 2-Point Link Figure 32, 5 ½-IN., 2-Point Link						
1	PAOZZ	1670-01-493-6420	81337	11-1-7026-2	Link, 2-Point, 5 ½-IN.	1
2	PAOZZ	5310-00-232-5165	81352	AN315-15R	Nut, Plain, Hex	2
3	PAOZZ	5365-00-007-3414	98750	65B3650	Spacer, Large	2
4	PAOZZ	5306-00-435-8994	81352	AN17-36A	Bolt, Machine	2
5	PAOZZ	1670-00-003-1954	81337	66B1883-2	Plate, Clevis, 5 ½-IN.	2
<b>END OF FIGURE</b>						





GROUP 0518 RELEASE AWAY STATIC LINE ASSEMBLY

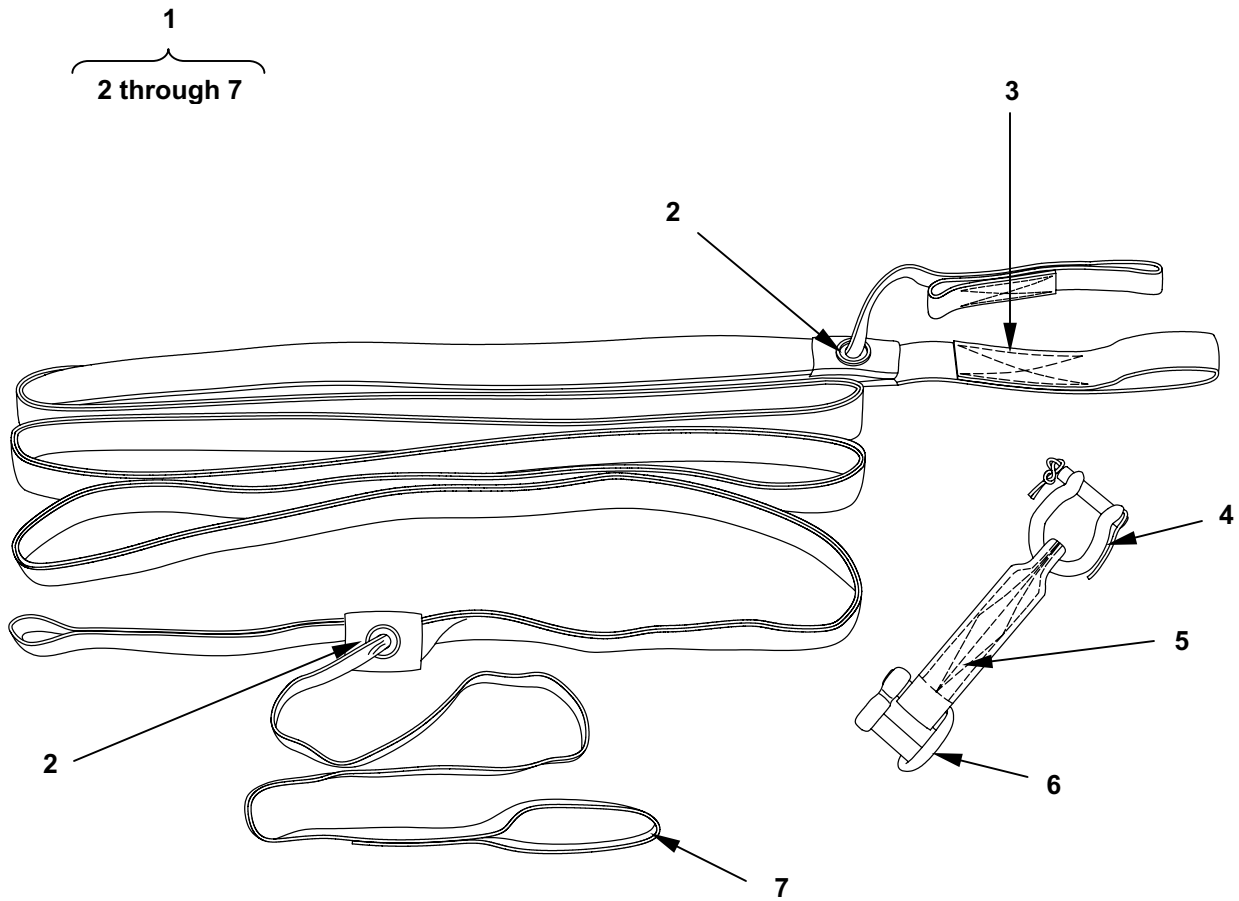


Figure 33. Release Away Static Line Assembly

**GROUP 0518 RELEASE AWAY STATIC LINE ASSEMBLY  
REPAIR PARTS LIST**

(1) ITEM NO.	(2) SMR CODE	(3) NSN	(4) CAGEC	(5) PART NUMBER	(6) DESCRIPTION AND USABLE ON CODE (UOC)	(7) QTY
Group 0518, Release Away Static Line Assembly Figure 33, Release Away Static Line Assembly						
1	PAOZZ	1670-01-487-5461	81337	11-1-4180-1	Assembly, Release Away Static Line	A/R
2	XAOZZ		81337	11-1-4179-1	Grommet	2
3	PAOZZ	1670-01-499-4464	81337	11-1-4177-1	Release Away Static Line, Main	1
4	PAOZZ	4030-00-678-8560	96906	MS70086-1	Clevis, Riser, Air Delivery, Type III	1
5	PAOZZ	1670-01-487-5466	81337	11-1-4178-1	Strap, Connector, 6- IN.	1
6	PAOZZ	1670-01-487-5462	81337	11-1-4259-1	Link, Connector, 1- Inch	1
7	XAOZZ		1HHQ4	PIA-W-5625	Release Line	1
<b>END OF FIGURE</b>						







GROUP 06 EXTRACTION PARACHUTE JETTISON SYSTEM (EPJS)

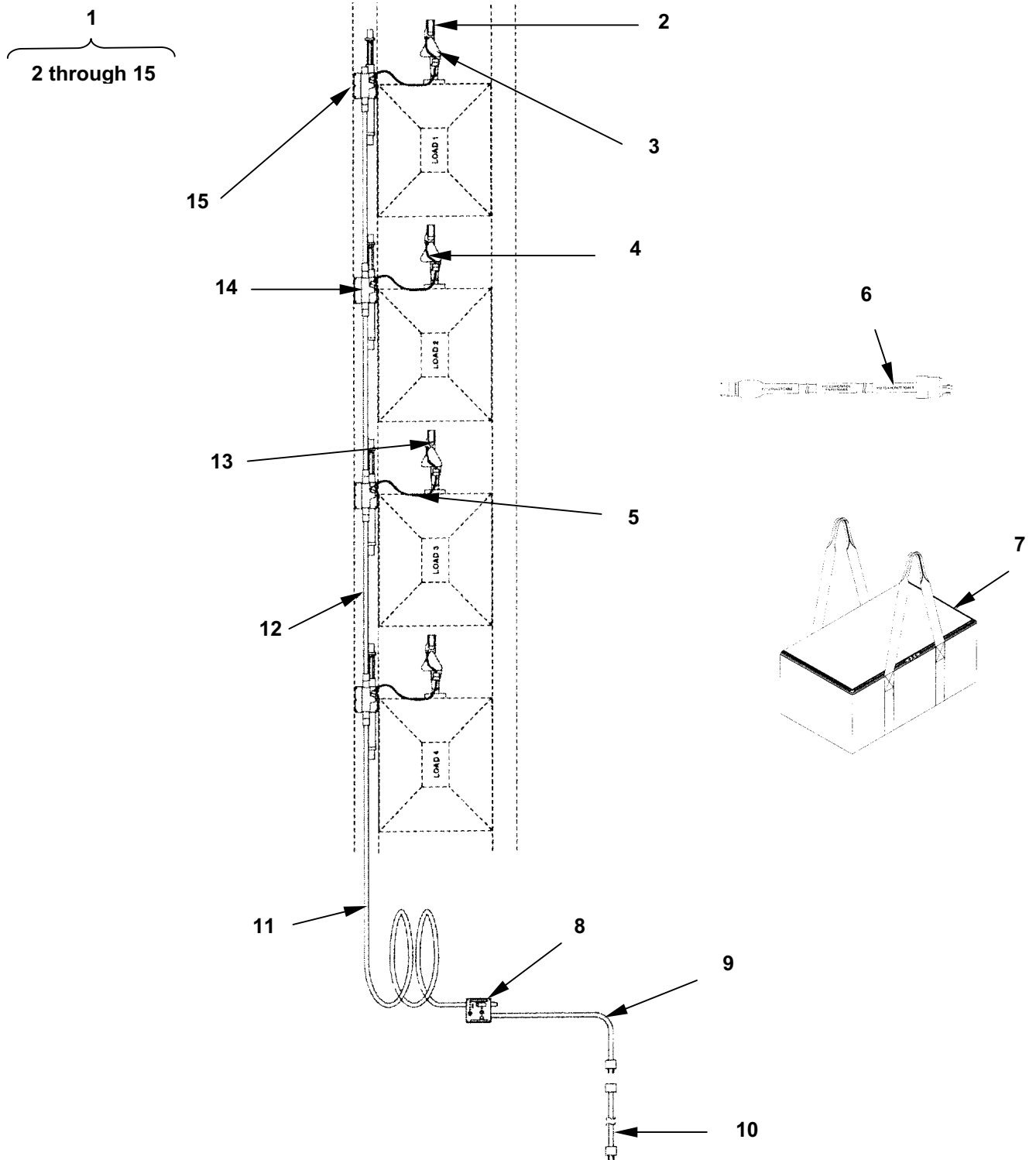


Figure 34. Extraction Parachute Jettison System (EPJS)

**GROUP 06 EXTRACTION PARACHUTE JETTISON SYSTEM (EPJS)  
REPAIR PARTS LIST**

(1) ITEM NO.	(2) SMR CODE	(3) NSN	(4) CAGEC	(5) PART NUMBER	(6) DESCRIPTION AND USABLE ON CODE (UOC)	(7) QTY
Group 06, Extraction Parachute Jettison System (EPJS) Figure 34, Extraction Parachute Jettison System (EPJS)						
1	PAOOO	1670-01-475-1990	52497	811-00429	Jettison System, Parachute, Extraction	1
2	PAOOO	1670-01-502-4003	52497	811-00414	EPJD	4
3	PAOOO	5340-01-494-6318	52497	821-00430	Protective Cover, EPJD	4
4	PAOZZ	6150-01-494-8722	52497	811-00481	Squib Cable	4
5	PAOZZ	6150-01-495-0652	52497	811-00423	Platform Cable, 10-FT	4
6	PAOZZ	6150-01-494-6315	52497	811-00631	Extension, Power Cable, 20-FT	1
7	PAOOO	1670-01-495-2016	52497	821-00457	Kit Bag	1
8	PAOOO	1670-01-493-7131	52497	811-00457	Control Box	1
9	PAOZZ	6150-01-495-2021	52497	811-00630	Power, Cable, 20-FT	1
10	PAOZZ	6150-01-494-3593	52497	811-00488	Extension, Cable, 4-FT	1
11	PAOZZ	6150-01-494-6316	52497	811-00468	Main Cable, 50-Ft	1
12	PAOZZ	6150-01-494-8724	52497	811-00467	Interconnect Cable, 10-FT	4
13	PAOZZ	1377-01-487-0716	52497	3205A5269	Squib Assembly	4
14	PAOOO	5935-01-494-7965	52497	811-00455	Y-Connector	4
15	PAOOO	1670-01-502-7542	52497	811-00480	Mounting Box	4
<b>END OF FIGURE</b>						





GROUP 0601 EXTRACTION PARACHUTE JETTISON DEVICE (EPJD)

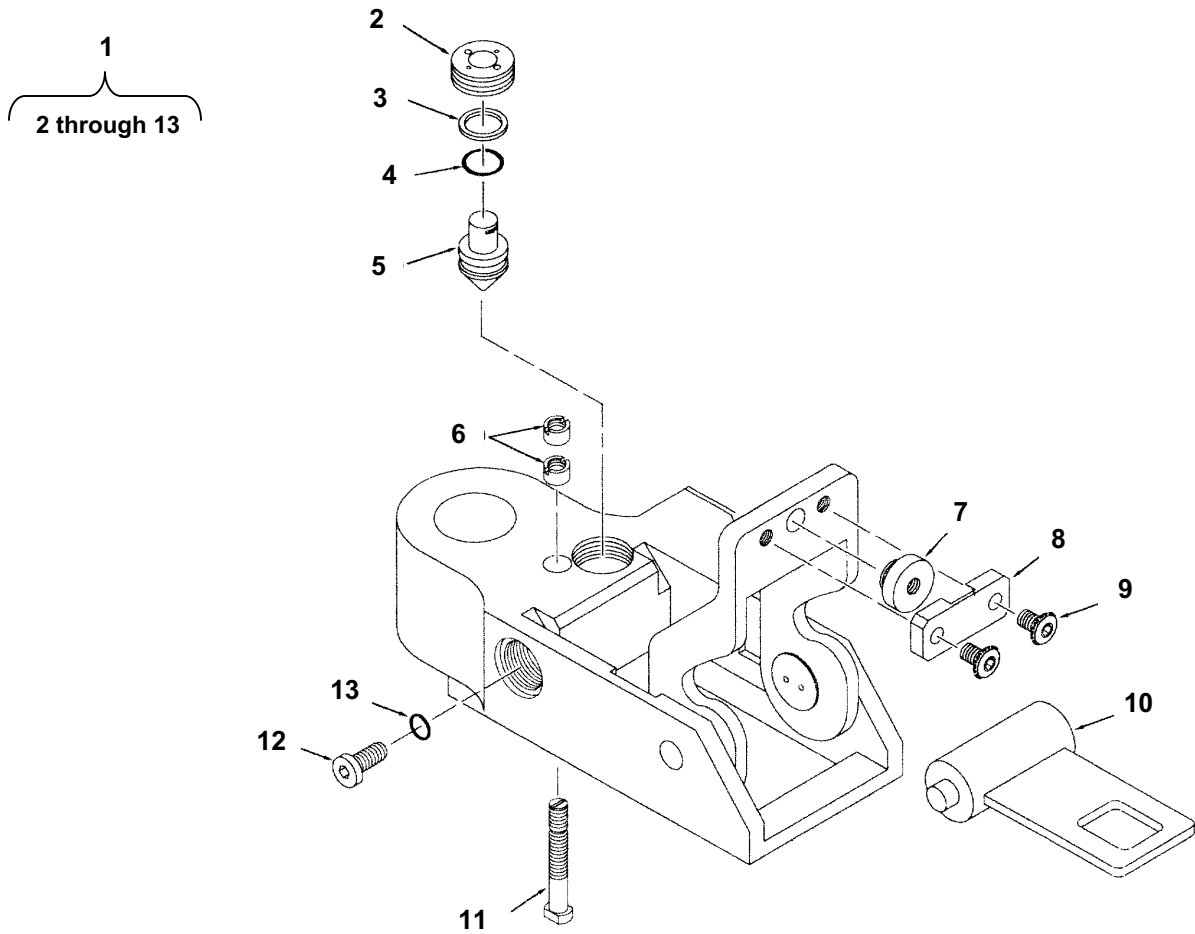


Figure 35. Extraction Parachute Jettison Device

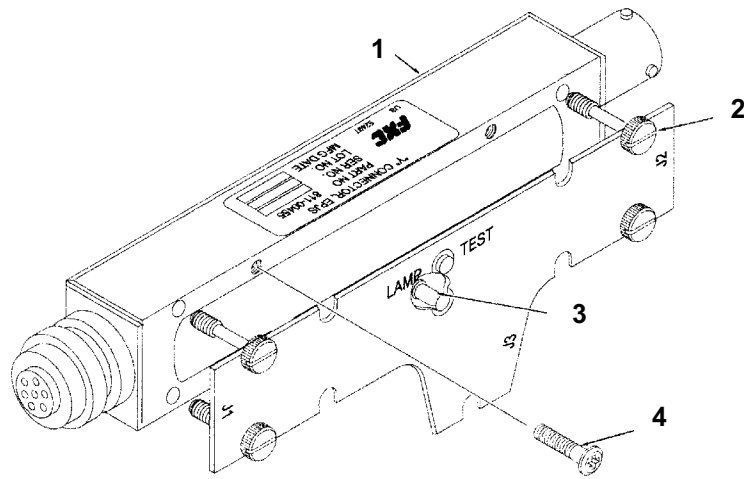
**GROUP 0601 EXTRACTION PARACHUTE JETTISON DEVICE  
REPAIR PARTS LIST**

(1) ITEM NO.	(2) SMR CODE	(3) NSN	(4) CAGEC	(5) PART NUMBER	(6) DESCRIPTION AND USABLE ON CODE (UOC)	(7) QTY
Group 0601, Extraction Parachute Jettison Device Figure 35, Extraction Parachute Jettison Device						
1	PAOOO		52497	811-00414	Jettison Device, Parachute, Extraction	4
2	XAOZZ		52497	311-21644	Stop, Piston	1
3	XAOZZ		52497	311-80313-015	Ring, Backup	1
4	XAOZZ		52497	311-80603-015	Packing, Preformed	1
5	XAOZZ		52497	311-21643	Piston	1
6	XAOZZ		52497	311-21646	Retainer, Shear Bolt	2
7	PAOZZ	5340-01-494-6312	52497	311-21647	Retainer, Latch	1
8	PAOZZ	5340-01494-6313	52497	311-21893	Clamp, Retainer	1
9	PAOZZ	5305-01-494-6314	52497	511-00695	Screw Cap, Hexagon Head	2
10	PAOZZ	1670-01-496-5833	52497	811-00496	Keeper, EPJD	1
11	XAOZZ		52497	311-21645	Bolt, Shear	1
12	PAOZZ		52497	311-21788	Plug, Cross Hole	1
13	XAOZZ		52497	311-81124	Packing, Preformed	1
<b>END OF FIGURE</b>						





**GROUP 0602 Y-CONNECTOR**

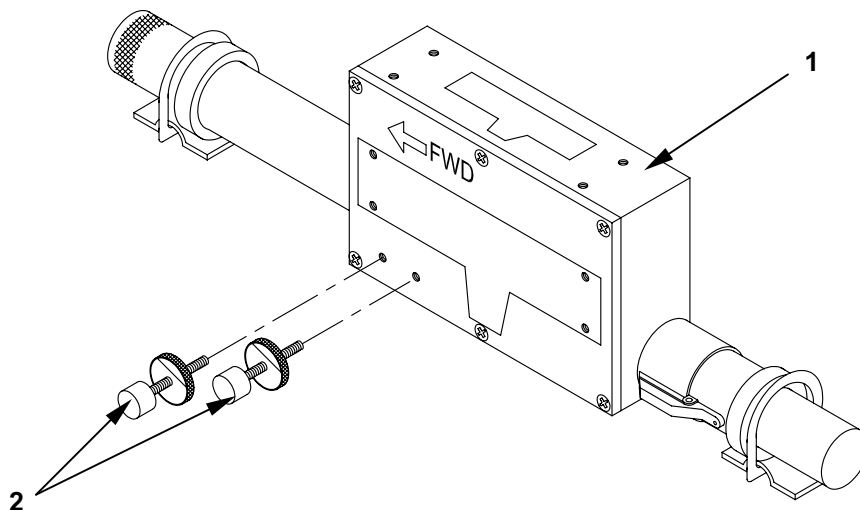


**Figure 36. Y-Connector**

(1) ITEM NO.	(2) SMR CODE	(3) NSN	(4) CAGEC	(5) PART NUMBER	(6) DESCRIPTION AND USABLE ON CODE (UOC)	(7) QTY
Group 0602 Y-Connector Figure 36, Y-Connector						
1	PAOOO	5935-01-494-7965	52497	811-00455	Y-Connector	4
2	XAOZZ		52497	311-81126	Screw, Thumb	4
3	PAOZZ	5980-01-495-2018	52497	811-00494	LED Blue	1
4	PAOZZ	5305-00-054-5649	52497	311-80266-15	Screw, Pan Head	5
<b>END OF FIGURE</b>						



**GROUP 0603 Y-CONNECTOR MOUNTING BOX (C-130; C-141; C-17)**

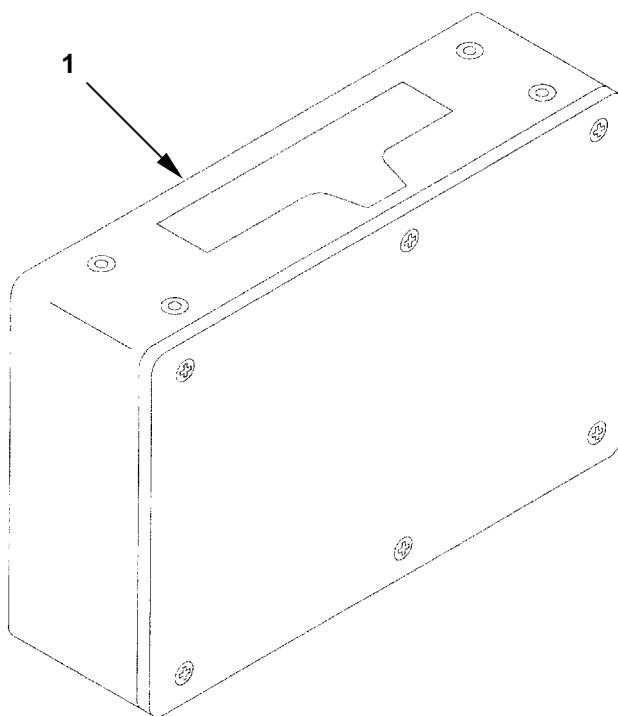


**Figure 37. Y-Connector Mounting Box (C-130; C-141; C-17)**

(1) ITEM NO.	(2) SMR CODE	(3) NSN	(4) CAGEC	(5) PART NUMBER	(6) DESCRIPTION AND USABLE ON CODE (UOC)	(7) QTY
Group 0603, Y-Connector Mounting Box Figure 37, Y-Connector Mounting Box (C-130; C-141; C-17)						
1	PAOOO		52497	811-00480	Mounting Box, Y-connector (C-130; C-141; C-17)	4
2	PAOOO		52497	511-00711	Stud, Bumper Assembly	2
<b>END OF FIGURE</b>						



**GROUP 0604 Y-CONNECTOR MOUNTING BOX (C-5)**

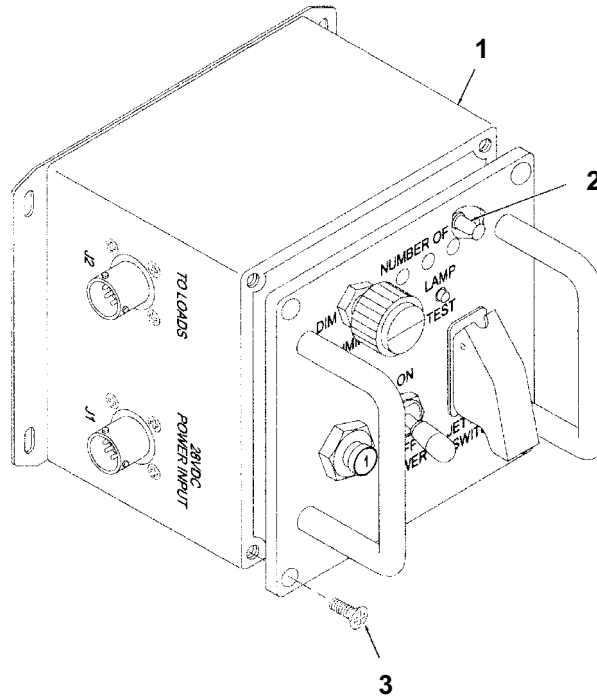


**Figure 38. Y-Connector Mounting Box (C-5)**

(1) ITEM NO.	(2) SMR CODE	(3) NSN	(4) CAGEC	(5) PART NUMBER	(6) DESCRIPTION AND USABLE ON CODE (UOC)	(7) QTY
Group 0604, Y-Connector Mounting Box Figure 38, Y-Connector Mounting Box (C-5)						
1	PAOZZ	1670-01-495-2017	52497	811-00480-1	Mounting Box, Y-connector (C-5)	4
<b>END OF FIGURE</b>						



**GROUP 0605 CONTROL BOX**



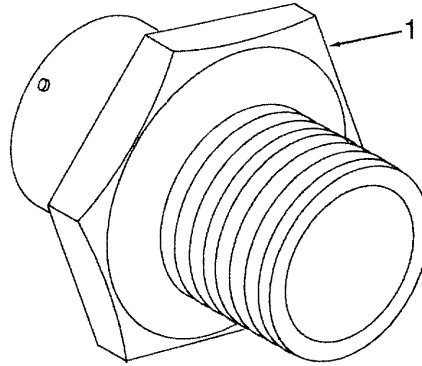
**Figure 39. Control Box**

(1) ITEM NO.	(2) SMR CODE	(3) NSN	(4) CAGEC	(5) PART NUMBER	(6) DESCRIPTION AND USABLE ON CODE (UOC)	(7) QTY
Group 0605, Control Box Figure 39, Control Box						
1	PAOOO	1670-01-493-7131	52497	811-00457	Box, Control	1
2	PAOZZ	5980-01-495-2018	52497	811-00494	LED, Blue	4
3	PAOZZ	5305-00-719-5064	52497	311-80268-30	Screw, Flat Head	4
<b>END OF FIGURE</b>						





**GROUP 0606 SQUIB ASSEMBLY**

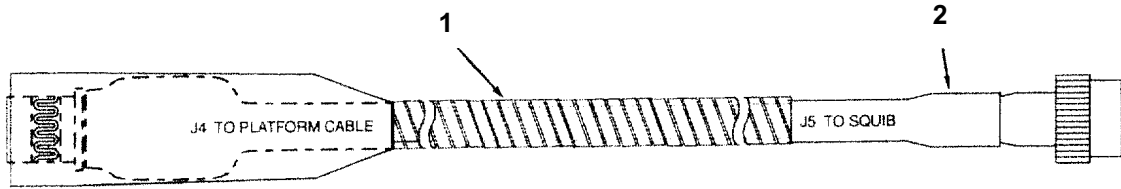


**Figure 40. Squib Assembly**

(1) ITEM NO.	(2) SMR CODE	(3) NSN	(4) CAGEC	(5) PART NUMBER	(6) DESCRIPTION AND USABLE ON CODE (UOC)	(7) QTY
Group 0606, Squib Assembly Figure 40, Squib Assembly						
1	PAOZZ	1377-01-487-0716	14720	3205AS269	Assembly, Squib	4
<b>END OF FIGURE</b>						



**GROUP 0607 EPJS SQUIB CABLE**

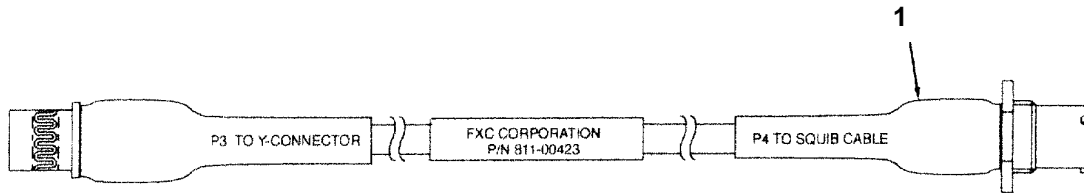


**Figure 41. EPJS Squib Cable**

(1) ITEM NO.	(2) SMR CODE	(3) NSN	(4) CAGEC	(5) PART NUMBER	(6) DESCRIPTION AND USABLE ON CODE (UOC)	(7) QTY
Group 0607, EPJS Squib Cable Figure 41, EPJS Squib Cable						
1	PAOZZ	NSN Pending	3AQ054	311-81204	Helical Bundle Wrap	AR
2	PAOZZ	6150-01-494-8722	52497	811-00481	Cable, Squib, EPJS	4
<b>END OF FIGURE</b>						



**GROUP 0608 10-FOOT PLATFORM CABLE**

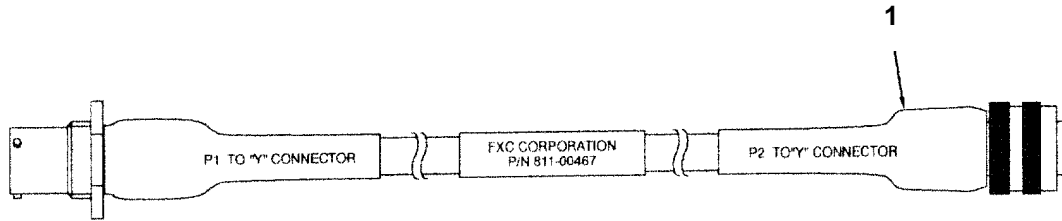


**Figure 42. 10-Foot Platform Cable**

(1) ITEM NO.	(2) SMR CODE	(3) NSN	(4) CAGEC	(5) PART NUMBER	(6) DESCRIPTION AND USABLE ON CODE (UOC)	(7) QTY
Group 0608, 10-Foot Platform Cable Figure 42, 10-Foot Platform Cable						
1	PAOZZ	6150-01-495-0652	52497	811-00423	Cable, Platform, 10-FT	4
<b>END OF FIGURE</b>						



**GROUP 0609 10-FOOT INTERCONNECT CABLE**



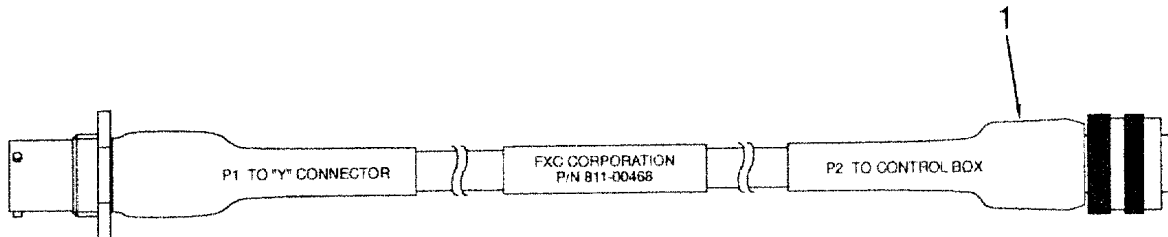
**Figure 43. 10-Foot Interconnect Cable**

(1) ITEM NO.	(2) SMR CODE	(3) NSN	(4) CAGEC	(5) PART NUMBER	(6) DESCRIPTION AND USABLE ON CODE (UOC)	(7) QTY
Group 0609, 10-Foot Interconnect Cable Figure 43, 10-Foot Interconnect Cable						
1	PAOZZ	6150-01-494-8724	52497	811-00467	Cable, Interconnect, 10-FT	3
<b>END OF FIGURE</b>						





**GROUP 0610 50-FOOT MAIN CABLE**

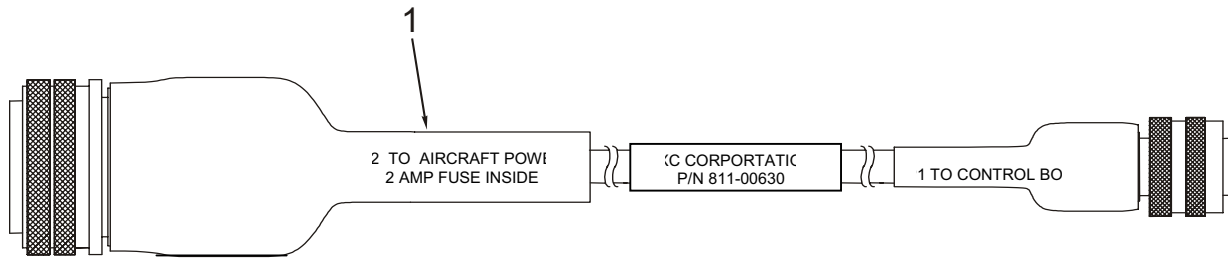


**Figure 44. 50-Foot Main Cable**

(1) ITEM NO.	(2) SMR CODE	(3) NSN	(4) CAGEC	(5) PART NUMBER	(6) DESCRIPTION AND USABLE ON CODE (UOC)	(7) QTY
Group 0610, 50-Foot Main Cable Figure 44, 50-Foot Main Cable						
1	PAOZZ	6150-01-494-6316	52497	811-00468	Cable, Main, 50-Foot	1
<b>END OF FIGURE</b>						



**GROUP 0611 20-FOOT POWER CABLE**

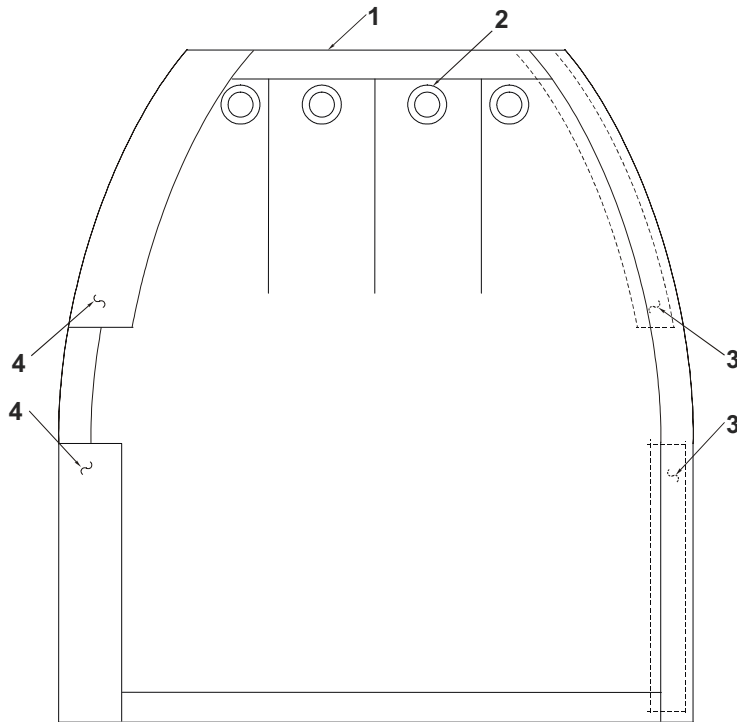


**Figure 45. 20-Foot Power Cable**

(1) ITEM NO.	(2) SMR CODE	(3) NSN	(4) CAGEC	(5) PART NUMBER	(6) DESCRIPTION AND USABLE ON CODE (UOC)	(7) QTY
Group 0611, 20-Foot Power Cable Figure 45, 20-Foot Power Cable						
1	PAOZZ	6150-01-495-2021	52497	811-00630	Cable, Power, EPJS, C/W 2 Amp Fuse	1
<b>END OF FIGURE</b>						



**GROUP 0612 PROTECTIVE COVER**

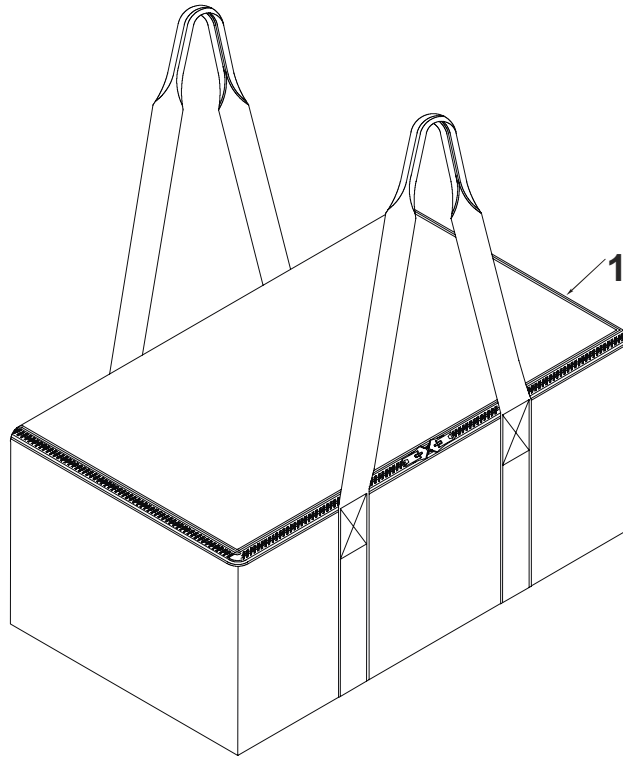


**Figure 46. Protective Cover**

(1) ITEM NO.	(2) SMR CODE	(3) NSN	(4) CAGEC	(5) PART NUMBER	(6) DESCRIPTION AND USABLE ON CODE (UOC)	(7) QTY
Group 0612, Protective Cover Figure 46, Protective Cover						
1	PAOZZ	5340-01-494-6318	52497	811-00430	Cover, Protective, 50- FT	4
2	PAOZZ	5120-00-221-1148	96906	MS20230BPS2	Grommet, Metallic, Spur, Die Set	4
3	PAOZZ	8315-00-066-5054	52497	MIL-T-21840	Tape, Pile, Fastener, 3/4-IN.	AR
4	PAOZZ	8315-00-006-9835	81349	MIL-T-21840	Tape, Hook, Fastener, 1 1/2-IN.	AR
<b>END OF FIGURE</b>						



**GROUP 0613 KIT BAG**



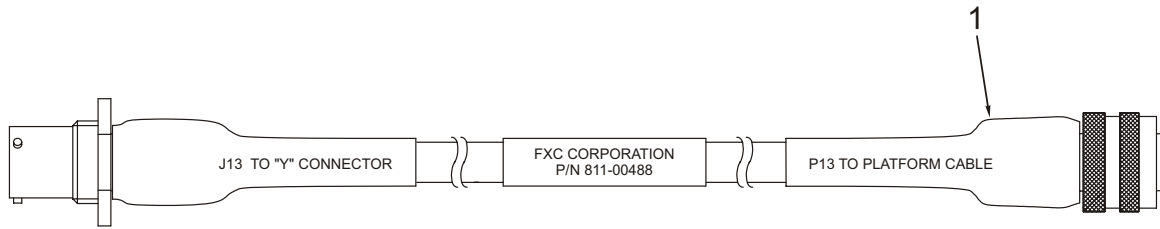
**Figure 47. Kit Bag**

(1) ITEM NO.	(2) SMR CODE	(3) NSN	(4) CAGEC	(5) PART NUMBER	(6) DESCRIPTION AND USABLE ON CODE (UOC)	(7) QTY
Group 0613, Kit Bag Figure 47, Kit Bag						
1	PAOZZ	1670-01-495-2016	52497	821-00457	Bag, Kit	4
<b>END OF FIGURE</b>						





**GROUP 0614 4-FOOT EXTENSION CABLE (C-5 and C-17)**

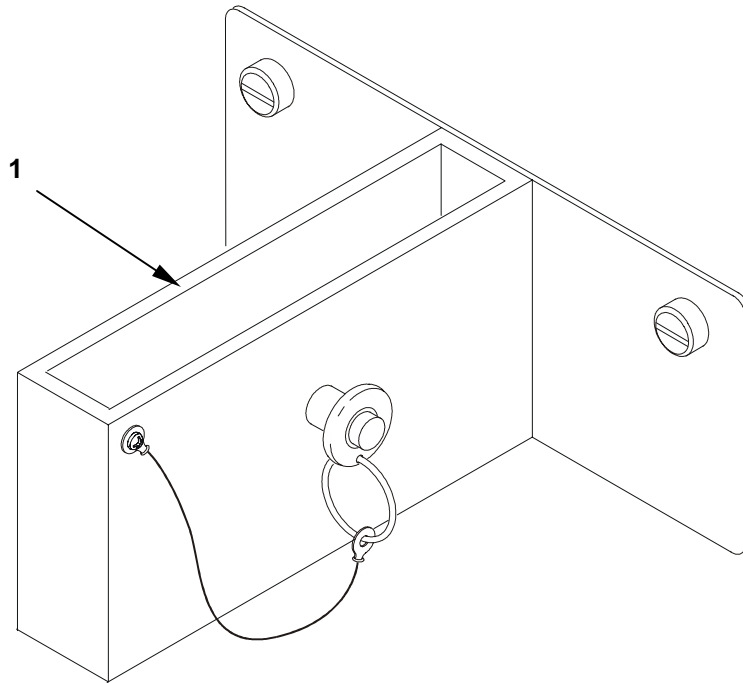


**Figure 48. 4-Foot Extension Cable (C-5 and C-17)**

(1) ITEM NO.	(2) SMR CODE	(3) NSN	(4) CAGEC	(5) PART NUMBER	(6) DESCRIPTION AND USABLE ON CODE (UOC)	(7) QTY
Group 0614, 4-Foot Extension Cable Figure 48, 4-Foot Extension Cable (C-5 and C-17)						
1	PAOZZ	6150-01-494-3593	52497	811-00488	Cable, Extension, 4-FT (C-5 and C-17)	4
<b>END OF FIGURE</b>						



**GROUP 0615 Y-CONNECTOR MOUNTING BOX TIE-DOWN BRACKET (C-5)**

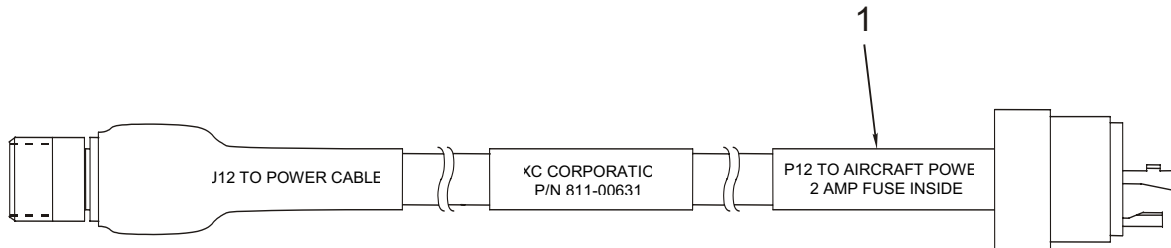


**Figure 49. Y-Connector Mounting Box Tie-Down Bracket (C-5)**

(1) ITEM NO.	(2) SMR CODE	(3) NSN	(4) CAGEC	(5) PART NUMBER	(6) DESCRIPTION AND USABLE ON CODE (UOC)	(7) QTY
Group 0615, Y-Connector Mounting Box Tie-Down Bracket (C-5) Figure 49, Y-Connector Mounting Box Tie-Down Bracket (C-5)						
1	PAOZZ	1670-01-494-7966	52497	811-00516	Bracket, Tie-down, Y-Connector Mounting Box (C-5)	4
<b>END OF FIGURE</b>						



**GROUP 0616 20-FOOT POWER CABLE EXTENSION (C-17 Only)**

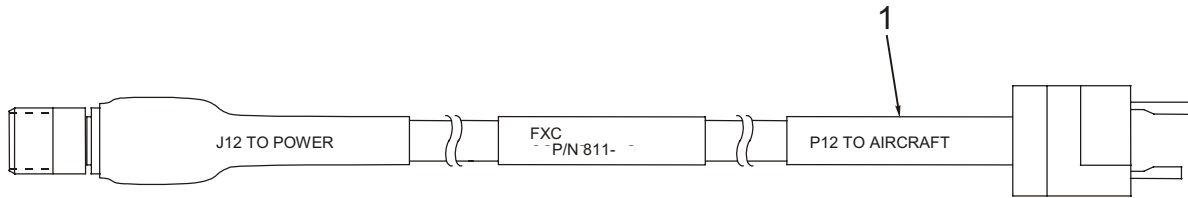


**Figure 50. 20-Foot Power Cable Extension (C-17)**

(1) ITEM NO.	(2) SMR CODE	(3) NSN	(4) CAGEC	(5) PART NUMBER	(6) DESCRIPTION AND USABLE ON CODE (UOC)	(7) QTY
Group 0616, 20-Foot Power Cable Extension (C-17) Figure 50, 20-Foot Power Cable Extension (C-17)						
1	PAOZZ	6150-01-494-6315	52497	811-00631	Cable, Extension, Power, EPJS, (C-17)	1
<b>END OF FIGURE</b>						



**GROUP 0617 1-FOOT POWER CABLE ADAPTER (C-5)**



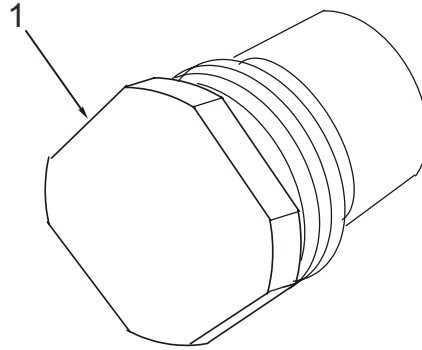
**Figure 51. 1-Foot Power Cable Adapter (C-5)**

(1) ITEM NO.	(2) SMR CODE	(3) NSN	(4) CAGEC	(5) PART NUMBER	(6) DESCRIPTION AND USABLE ON CODE (UOC)	(7) QTY
Group 0617, 1-Foot Power Cable Adapter (C-5) Figure 51, 1-Foot Power Cable Adapter (C-5)						
1	PAOZZ	6150-01-494-6317	52497	811-00495	Adapter, Power Cable, 1-Foot (C-5)	1
<b>END OF FIGURE</b>						





**GROUP 0618 SAFETY CAP**

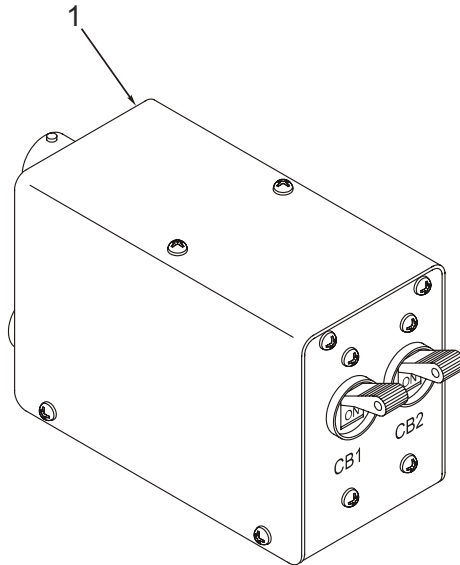


**Figure 52. Safety Cap**

(1) ITEM NO.	(2) SMR CODE	(3) NSN	(4) CAGEC	(5) PART NUMBER	(6) DESCRIPTION AND USABLE ON CODE (UOC)	(7) QTY
Group 0618, Safety Cap Figure 52, Safety Cap						
1	PAOZZ	5935-01-494-8723	52497	811-00493	Cap, Safety, Squib Cable	4
<b>END OF FIGURE</b>						



**GROUP 0619 INITIATOR SIMULATOR**

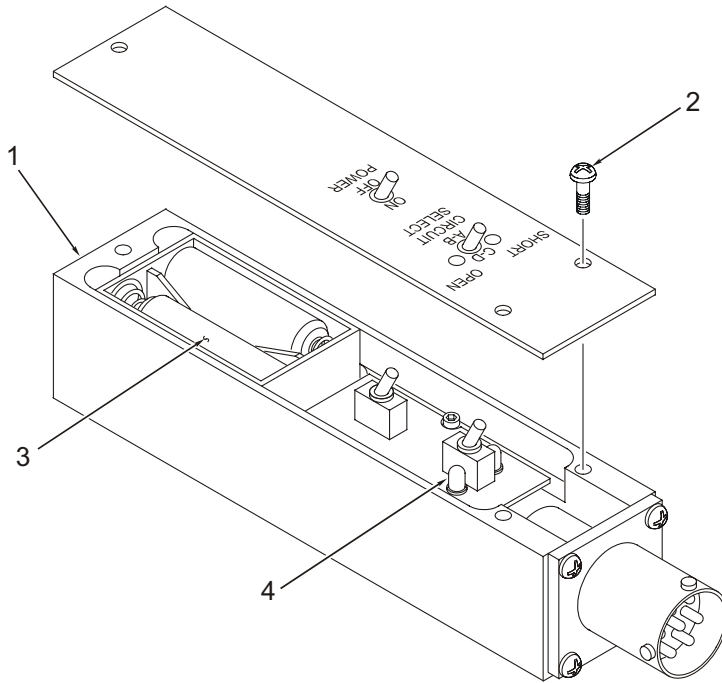


**Figure 53. Initiator Simulator**

(1) ITEM NO.	(2) SMR CODE	(3) NSN	(4) CAGEC	(5) PART NUMBER	(6) DESCRIPTION AND USABLE ON CODE (UOC)	(7) QTY
Group 0619, Initiator Simulator Figure 53, Initiator Simulator						
1	PAOZZ	1670-01-496-4748	52497	811-00444	Simulator, Initiator	4
<b>END OF FIGURE</b>						



**GROUP 0620 SQUIB TESTER**

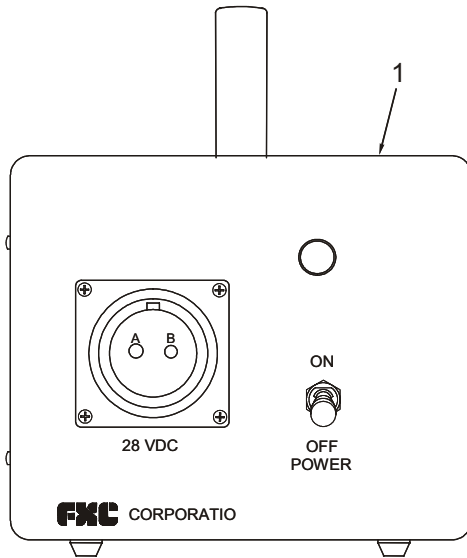


**Figure 54. Squib Tester**

(1) ITEM NO.	(2) SMR CODE	(3) NSN	(4) CAGEC	(5) PART NUMBER	(6) DESCRIPTION AND USABLE ON CODE (UOC)	(7) QTY
Group 6020, Squib Tester Figure 54, Squib Tester						
1	PAOZZ	6625-01-495-2015	52497	811-00491	Tester, Squib	1
2	PAOZZ	5305-00-054-5649	52497	311-80266-15	Screw, Pan HD	3
3	PAOZZ	5980-01-494-8721	52497	811-00534	LED, Red	2
4	PAOZZ		52497	311-81140	Battery, AAA	2
<b>END OF FIGURE</b>						



**GROUP 0621 28 VDC POWER SUPPLY**



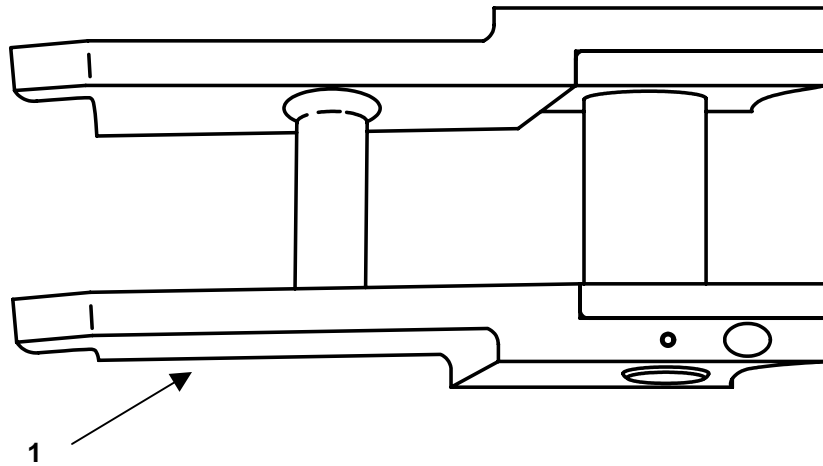
**Figure 55. 28 VDC Power Supply**

(1) ITEM NO.	(2) SMR CODE	(3) NSN	(4) CAGEC	(5) PART NUMBER	(6) DESCRIPTION AND USABLE ON CODE (UOC)	(7) QTY
Group 0621, 28 VDC Power Supply Figure 55, 28 VDC Power Supply						
1	PAOZZ	6130-01-494-8726	52497	611-00189	Power Supply, 28 VDC	1
<b>END OF FIGURE</b>						





**GROUP 07 LINK, PARACHUTE CONNECTOR**



■ **Figure 56. Parachute Connector Link**

(1) ITEM NO.	(2) SMR CODE	(3) NSN	(4) CAGEC	(5) PART NUMBER	(6) DESCRIPTION AND USABLE ON CODE (UOC)	(7) QTY
Group 07, Link, Parachute Connector Figure 56, Link, Parachute Connector						
1	PAOZZ	1670-01-483-8259	65141	USA-TRMOD	Link, Parachute Connector	1
<b>END OF FIGURE</b>						



**GROUP 90 BULK MATERIALS  
REPAIR PARTS LIST**

(1) ITEM NO.	(2) SMR CODE	(3) NSN	(4) CAGEC	(5) PART NO.	(6) DESCRIPTION AND USEABLE ON CODE (UOC)	(7) QTY
<b>Group 90, Bulk Materials</b>						
1	PAOZZ	8305-00-765-2863	81349	MIL-C-7219	Cloth, Nylon, Duck, Type III, 7.25 Oz, Sage Green	YD
2	PAOZZ	8305-00-205-1478	81349	MIL-C-7350	Cloth, Nylon, Parachute, Type II, 3.5 Oz, Natural	YD
3	PAOZZ	4020-00-965-0473	81349	MIL-C-7515	Cord, Coreless, Type V, OD	YD
4	PAOZZ	4020-00-262-2020	81349	MIL-C-7515	Cord, Nylon, Coreless, Type IV, OD	YD
5	PAOZZ	4020-00-965-0435	81349	MIL-C-7515	Cord, Nylon, Coreless, Type VI, OD	YD
6	PAOZZ	4020-00-965-0473	81349	MIL-C-7515	Cord, Nylon, Type V, OD	YD
7	PAOZZ	8315-00-253-6292	81349	MIL-T-43566	Tape, Cotton, Type I, 1½-IN., Class IV, OD,	YD
8	PAOZZ	4020-00-753-6555	81349	MIL-T-43435	Tape, Lacing and Tying	RL
9	PAOZZ	8315-00-255-7673	81349	PIA-T-5038	Tape, Nylon, Type III, ½-IN. Wide, OD	YD
10	PAOZZ	8315-00-176-8083	81349	PIA-T-5038	Tape, Nylon, Type III, ¾-IN. Wide, OD	YD
11	PAOZZ	7510-00-633-0199	81348	PPP-T-60	Tape, Pressure Sensitive, Type III, 1-IN. Wide	RL
12	PAOZZ	8315-00-253-6292	81349	MIL-T-43566	Tape, Textile, Type I, Class IV, 1½-IN. Wide, OD	YD
13	PAOZZ	8315-00-126-8083	81349	PIA-T-5038	Tape, Textile, Type III, ¾-IN. Wide	YD
14	PAOZZ	8310-00-917-3945	81348	V-T-276	Thread, Cotton, Type I, Ticket 8/7, Natural	YD
15	PAOZZ	8310-00-248-9714	81348	V-T-295	Thread, Nylon, Type I, Size 3, Class I, Natural	YD
16	PAOZZ	8310-00-267-3027	81348	V-T-295	Thread, Nylon, Type I, Size 3, Class I, OD	YD
17	PAOZZ	8310-00-248-9716	81348	V-T-295	Thread, Nylon, Type I, Size 6, Class I, Natural	YD

**GROUP 90 BULK MATERIALS  
REPAIR PARTS LIST**

(1) ITEM NO.	(2) SMR CODE	(3) NSN	(4) CAGEC	(5) PART NO.	(6) DESCRIPTION AND USEABLE ON CODE (UOC)	(7) QTY
18	PAOZZ	8310-00-262-2780	81348	V-T-295	Thread, Nylon, Type I, Size 6, Class I, OD	YD
19	PAOZZ	8310-00-262-2770	81349	V-T-295	Thread, Nylon, Type I, Size E, Class I, Nat.	YD
20	PAOZZ	8310-00-262-2772	81349	V-T-295	Thread, Nylon, Type I, Size E, Class I, OD	YD
21	PAOZZ	8310-00-267-3024	81348	V-T-295	Thread, Nylon, Type I, Size FF, Class I, Nat.	YD
22	PAOZZ	8310-00-227-1244	81348	V-T-295	Thread, Nylon, Type I, Size FF, Class I, OD	YD
23	PAOZZ	8305-00-268-2411	81349	MIL-T-5661	Webbing, Cotton, Type I, ¼-IN. Wide, Nat.	YD
24	PAOZZ	8305-00-753-6086	81349	MIL-W-5665	Webbing, Cotton, Type X, ¾-IN. Wide, OD	YD
25	PAOZZ	8305-00-082-5751	81349	PIA-W-5625	Webbing, Nylon, Tubular, ¾-IN. Wide, Nat.	YD
26	PAOZZ	8305-00-268-2455	81349	PIA-W-5625	Webbing, Nylon, Tubular, 1-IN. Wide, OD	YD
27	PAOZZ	8305-00-268-2453	81349	PIA-W-5625	Webbing, Nylon, Tubular, Textile, ½-IN. Wide	YD
28	PAOZZ	8305-00-263-2472	81349	MIL-T-5038	Webbing, Nylon, Type IV, 1½ -IN. Wide, OD	YD
29	PAOZZ	8305-00-261-8579	81349	PIA-T-5038	Webbing, Nylon, Type IV, 1-IN. Wide, OD	YD
30	PAOZZ	8305-00-263-3598	81349	PIA-W-4088	Webbing, Nylon, Type VIII, 1 <sup>23</sup> / <sub>32</sub> .IN. Wide, OD	YD

---

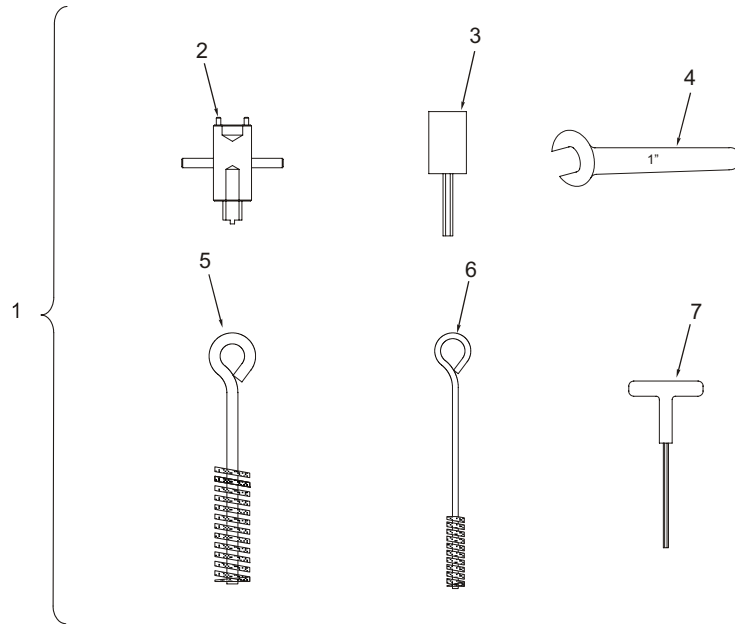
**GROUP 90 BULK MATERIALS  
REPAIR PARTS LIST**


---

(1) ITEM NO.	(2) SMR CODE	(3) NSN	(4) CAGEC	(5) PART NO.	(6) DESCRIPTION AND USEABLE ON CODE (UOC)	(7) QTY
31	PAOZZ	8305-00-261-8585	81349	PIA-W-4088	Webbing, Nylon, Type VIII, CG 483	YD
32	PAOZZ	8305-01-206-9219	81349		Webbing, Nylon, Type XXVI	YD
33	PAOZZ		81349	MIL-W-42765	Webbing, Textile, Cotton, Type VIII, Class R, OD	YD
34	PAOZZ	8305-00-261-8579	81349	MIL-T-5038	Webbing, Textile, Nylon, Type IV, 1-IN. Wide, OD	YD
35	PAOZZ	8305-00-260-2564	81349	MIL-W-5665	Webbing, Textile, Type VIII, Class 2B, OD	YD
<b>END OF FIGURE</b>						



**ANCILLARY EQUIPMENT FOR LOW VELOCITY AIR DROP SYSTEM  
SPECIAL TOOLS LIST**



(1) ITEM NO.	(2) SMR CODE	(3) NSN	(4) CAGEC	(5) PART NUMBER	(6) DESCRIPTION AND USABLE ON CODE (UOC)	(7) QTY
Group 95, Special Tools Figure 56, Special Tools						
1	PAOZZ	6130-01-494-8726	52497	811-00469	Tool Kit, Refurbish, EPJD	1
2	PAOZZ		52497	811-00470	Wrench, Piston, Stop/Shear Bolt Retainer	1
3	XAOZZ		52497	811-00532	Socket, Hex Bit, <sup>5</sup> / <sub>32</sub> -IN.	1
4	XAOZZ		52497	811-00531	Wrench, Open End, 1- IN.	1
5	PAOZZ		52497	811-00471	Brush, Bristle	1
6	PAOZZ		52497	811-00471-1	Brush, Bristle	1
7	XAOZZ		52497	811-00535	Drive, Hex, T-Handle, <sup>5</sup> / <sub>32</sub> -IN.	1
<b>END OF FIGURE</b>						

**END OF WORK PACKAGE**





---

**ANCILLARY EQUIPMENT FOR LOW VELOCITY AIR DROP SYSTEM (LVADS)  
NATIONAL STOCK NUMBER (NSN) INDEX**


---

<b>STOCK NUMBER</b>	<b>FIGURE</b>	<b>ITEM</b>
1670-00-003-1953	16	6
	31	5
1670-00-003-1954	16	4
	32	5
5365-00-005-1577	16	3
1670-00-006-2752	17	1
8315-00-006-9835	46	4
5365-00-007-3414	16	7
	31	3
1670-00-007-3414	32	3
5340-00-040-8219	22	1
7510-00-053-0942	1	1
5305-00-054-5649	36	4
	54	2
5305-00-058-4007	5	6
5315-00-058-9765	8	16
8315-00-066-5054	46	3
1670-00-078-4319	25	1
8305-00-082-5751	BULK	25
4030-00-090-5354	19	4
5320-00-117-6829	5	3
8315-00-126-8083	BULK	13
5365-00-139-4990	9	11
	10	2
	12	17
	13	2
1670-00-157-6527	2	14
	7	5
1670-00-162-4979	2	6
	3	1
1670-00-162-4981	2	7
	4	1
5315-00-166-5441	8	23
8315-00-176-8083	BULK	10
5305-00-177-5617	19	6
5365-00-180-5850	3	3
5315-00-200-3183	8	20
8305-00-205-1478	BULK	2
5306-00-207-8362	9	20
5120-00-221-1148	46	2

---

**ANCILLARY EQUIPMENT FOR LOW VELOCITY AIR DROP SYSTEM (LVADS)  
NATIONAL STOCK NUMBER (NSN) INDEX**


---

<b>STOCK NUMBER</b>	<b>FIGURE</b>	<b>ITEM</b>
8310-00-227-1244	BULK	22
5310-00-232-5135	31	2
5310-00-232-5165	16	5
	17	4
	32	2
8310-00-248-9714	BULK	15
8310-00-248-9716	BULK	17
8315-00-253-6292	BULK	7
	BULK	12
8315-00-255-7673	BULK	9
8305-00-260-2564	BULK	35
8305-00-261-8579	BULK	29
	BULK	34
8305-00-261-8585	BULK	31
4020-00-262-2020	BULK	4
8310-00-262-2770	BULK	19
8310-00-262-2772	BULK	20
8310-00-262-2780	BULK	18
8305-00-263-2472	BULK	28
8305-00-263-3598	BULK	30
8310-00-267-3024	BULK	21
8310-00-267-3027	BULK	16
5305-00-267-8953	5	15
8305-00-268-2411	BULK	23
8305-00-268-2453	BULK	27
8305-00-268-2455	BULK	26
1670-00-360-0328	20	2
1670-00-360-0329	18	1
1670-00-400-2771	9	13
	10	1
	12	15
	13	1
1670-00-400-2772	9	25
5365-00-405-9293	4	2
5365-00-405-9293	23	3

---

**ANCILLARY EQUIPMENT FOR LOW VELOCITY AIR DROP SYSTEM (LVADS)  
NATIONAL STOCK NUMBER (NSN) INDEX**


---

<b>STOCK NUMBER</b>	<b>FIGURE</b>	<b>ITEM</b>
4010-00-431-8490	9	31
	12	4
4030-00-432-2516	19	9
1670-00-434-5782	2	4
	7	4
1670-00-434-5783	2	1
1670-00-434-5785	2	2
1670-00-434-5787	2	3
1670-00-434-5795	2	12
	7	3
1670-00-434-5797	2	10
	7	1
1670-00-434-5798	2	11
	7	2
5306-00-435-8994	16	2
	17	2
	31	4
	32	4
3990-00-437-0292	27	3
5306-00-451-1136	9	10
5365-00-451-8290	9	15
	12	21
4030-00-452-2568	8	3
1670-00-516-8405	30	3
1670-00-516-9063	30	1
5310-00-582-5965	5	14
7510-00-633-0199	BULK	11
4030-00-678-8560	33	4
4030-00-678-8562	19	1
5315-00-702-1301	8	27
5305-00-719-5064	39	3
8305-00-753-6086	BULK	24
4020-00-753-6555	BULK	8
8305-00-765-2863	BULK	1
5310-00-776-1963	3	4

**ANCILLARY EQUIPMENT FOR LOW VELOCITY AIR DROP SYSTEM (LVADS)  
NATIONAL STOCK NUMBER (NSN) INDEX**

**NATIONAL STOCK NUMBER INDEX - continued**

<b>STOCK NUMBER</b>	<b>FIGURE</b>	<b>ITEM</b>
5310-00-776-1963	4	5
	23	4
1670-00-783-5988	15	1
5310-00-809-8546	8	5
5315-00-812-3752	8	22
5315-00-812-3766	7	7
5315-00-839-2325	7	6
	8	4
5310-00-842-1190	19	3
5310-00-891-3428	19	5
8310-00-917-3945	BULK	14
5310-00-920-9369	12	33
5310-00-925-9642	9	4
	9	14
5310-00-926-1852	9	2
5310-00-937-0147	27	2
1670-00-937-0271	27	1
5340-00-937-0273	27	4
5310-00-939-0783	5	4
5305-00-940-8069	19	2
5310-00-943-9897	9	12
	10	3
	12	18
	12	23
	13	3
5305-00-957-7811	9	5
4020-00-965-0435	BULK	5
4020-00-965-0473	BULK	3
	BULK	6
5310-00-982-6809	12	5
5305-00-983-7428	12	35
5315-00-990-1338	8	19
6645-01-017-9534	11	5
	14	5
5325-01-028-0945	20	1
1670-01-062-6301	1	2
1670-01-062-6302	1	2
1670-01-062-6303	1	2
1670-01-062-6304	1	2
1670-01-062-6305	1	2

---

**ANCILLARY EQUIPMENT FOR LOW VELOCITY AIR DROP SYSTEM (LVADS)  
NATIONAL STOCK NUMBER (NSN) INDEX**


---

<b>STOCK NUMBER</b>	<b>FIGURE</b>	<b>ITEM</b>
1670-01-062-6306	1	2
1670-01-062-6307	1	2
1670-01-062-6308	1	2
1670-01-062-6309	1	2
1670-01-062-6310	1	2
1670-01-062-6311	1	2
1670-01-062-6312	1	2
1670-01-062-6313	1	2
1670-01-063-7760	1	2
1670-01-063-7761	1	2
1670-01-064-4451	1	2
1670-01-064-4452	1	2
1670-01-064-4453	1	2
1670-01-064-4454	1	2
1670-01-087-1604	9	18
5325-01-087-1605	9	9
5365-01-092-7849	17	3
1670-01-097-8816	9	1
1670-01-097-8817	12	1
1670-01-098-4189	11	3
	14	3
1670-01-102-8753	9	29
	12	14
5315-01-102-8754	9	28
	12	13
5315-01-102-8755	9	27
	12	12
1670-01-107-7651	1	2
1670-01-107-7652	1	2
6645-01-108-3457	9	26
	12	11
5315-01-134-9400	8	18
1670-01-141-1522	26	1
1670-01-182-1979	2	15
	8	1
8305-01-206-9209	BULK	32
4010-01-216-6763	8	2
1670-01-307-0155	23	1
1670-01-307-0534	12	9
5340-01-310-2323	12	30

---

**ANCILLARY EQUIPMENT FOR LOW VELOCITY AIR DROP SYSTEM (LVADS)  
NATIONAL STOCK NUMBER (NSN) INDEX**


---

<b>STOCK NUMBER</b>	<b>FIGURE</b>	<b>ITEM</b>
5315-01-312-1188	8	17
3040-01-313-8016	12	32
1670-01-315-4562	12	8
1670-01-315-7001	8	9
5315-01-318-6886	8	13
5306-01-318-9533	12	27
5360-01-320-0999	8	8
5306-01-320-1048	12	19
5307-01-320-7260	12	34
5365-01-320-8511	8	14
5365-01-321-0603	12	29
5365-01-321-2530	12	22
5360-01-322-3607	8	15
5340-01-323-5678	12	25
1670-01-326-7309	2	5
1670-01-333-1748	12	20
1670-01-333-6082	28	1
	30	2
1670-01-344-0825	29	1
5365-01-354-8932	3	2
	6	3
5315-01-357-8453	8	24
5310-01-408-2779	9	3
1620-01-434-5796	2	13
1670-01-470-3696	2	8
	5	1
1670-01-470-8333	2	9
	6	1
5306-01-471-5336	4	4
	23	2
5306-01-471-5419	6	4
5306-01-471-5421	3	6
1670-00-473-5116	21	1
1670-01-475-1990	34	1
1670-01-483-8259	56	1
1377-01-487-0716	34	13
	40	1
1670-01-487-5461	33	1
1670-01-487-5462	33	6
1670-01-487-5466	33	5
1670-01-493-6418	31	1

---

**ANCILLARY EQUIPMENT FOR LOW VELOCITY AIR DROP SYSTEM (LVADS)  
NATIONAL STOCK NUMBER (NSN) INDEX**


---

<b>STOCK NUMBER</b>	<b>FIGURE</b>	<b>ITEM</b>
1670-01-493-6420	32	1
1670-01-493-7131	34	10
	39	1
6150-01-494-3593	34	8
	48	1
5340-01-494-6312	35	7
5340-01-494-6313	35	8
5305-01-494-6314	35	9
6150-01-494-6315	34	6
	50	1
6150-01-494-6316	34	11
	44	1
6150-01-494-6317	51	1
5340-01-494-6318	34	3
	46	1
5935-01-494-7965	34	14
	36	1
1670-01-494-7966	49	1
5980-01-494-8721	54	3
6150-01-494-8722	34	4
	41	2
5935-01-494-8723	52	1
6150-01-494-8724	34	12
	43	1
6130-01-494-8726	55	1
6150-01-495-0652	34	5
	42	1
6625-01-495-2015	54	1
1670-01-495-2016	34	7
	47	1
1670-01-495-2017	38	1
5980-01-495-2018	36	3
	39	2
6150-01-495-2021	34	9
	45	1
1670-01-496-4748	53	1
1670-01-496-5833	35	10
1670-01-499-4464	33	3

---

**ANCILLARY EQUIPMENT FOR LOW VELOCITY AIR DROP SYSTEM (LVADS)  
NATIONAL STOCK NUMBER (NSN) INDEX**

---

<b>STOCK NUMBER</b>	<b>FIGURE</b>	<b>ITEM</b>
1670-01-502-4003	34	2
	35	1
1670-01-502-7542	34	15
	37	1

**END OF FIGURE**



**ANCILLARY EQUIPMENT FOR LOW VELOCITY AIR DROP SYSTEMS (LVADS)  
PART NUMBER INDEX**

<b>PART NUMBER</b>	<b>FIGURE</b>	<b>ITEM</b>	<b>PART NUMBER</b>	<b>FIGURE</b>	<b>ITEM</b>
AN17-36A	16	2	V-T-295	BULK	20
	17	2		BULK	21
	31	4		BULK	22
	32	4	11-1-129	21	1
AN315-15R	16	5	11-1-1487-2	9	1
	17	4	11-1-1488	9	24
	31	2	11-1-1489	9	19
	32	2	11-1-1490	9	18
ANSI B18.2.2	6	2	11-1-1491	9	8
ANSI B18.6.3	11	4	11-1-1492	9	9
	14	4	11-1-1494	9	22
ASME B18.8.1	7	6	11-1-1495	9	23
ASME/ANSI B18.3	12	35	11-1-1496	9	30
B1821BH025F063N	5	15	11-1-1497	9	17
B1821BH075F450N	19	2	11-1-1499	9	15
B1821BH100F475N	19	6		12	21
MIL-C-7219	BULK	1	11-1-1500	9	7
MIL-C-7350	BULK	2	11-1-1715-1	2	7
MIL-C-7515	BULK	3		4	1
	BULK	4	11-1-1715-2	23	1
	BULK	5	11-1-1716	4	6
	BULK	6	11-1-1717	4	3
MIL-DTL-6458D	30	3		23	5
MIL-G-16491	20	1	11-1-1718	4	2
MIL-T-21840	46	3		23	3
	46	4	11-1-1721	2	6
MIL-T-25959	30	1		3	1
MIL-T-43435	BULK	8	11-1-1722	3	2
MIL-T-43566	BULK	7		6	3
	BULK	12	11-1-1723	3	3
MIL-T-5038	BULK	28	11-1-1724	3	5
	BULK	29	11-1-1725	2	8
	BULK	34		5	1
MIL-T-5661	BULK	23	11-1-1726	5	16
MIL-W-42765	BULK	33	11-1-1727-3	5	2
MIL-W-5665	BULK	24	11-1-1727-5	5	17
	BULK	35	11-1-1728	5	10
PIA-T-5038	BULK	9	11-1-1729	5	12
	BULK	10	11-1-1730	5	11
	BULK	13	11-1-1731	5	9
PIA-W-4088	BULK	30	11-1-1732	5	13
	BULK	31	11-1-1733	5	18
PIA-W-5625	BULK	25	11-1-1734	5	5
	BULK	26	11-1-1735	5	7
	BULK	27	11-1-1736	5	8
PPP-T-60	BULK	11	11-1-1737	2	15
USA-TRMOD	56	1		8	1
V-T-276	BULK	14	11-1-1738	8	9
V-T-295	BULK	15	11-1-1739	8	7
	BULK	16	11-1-1740	8	26
V-T-295	BULK	17	11-1-1741	8	10
	BULK	18	11-1-1742	8	21
	BULK	19	11-1-1743	8	11

**ANCILLARY EQUIPMENT FOR LOW VELOCITY AIR DROP SYSTEMS (LVADS)  
PART NUMBER INDEX**

<u>PART NUMBER</u>	<u>FIGURE</u>	<u>ITEM</u>	<u>PART NUMBER</u>	<u>FIGURE</u>	<u>ITEM</u>
11-1-1744	8	12	11-1-3723	12	22
11-1-1745	8	6	11-1-3724	12	32
11-1-1746	8	25	11-1-3725	12	20
11-1-1747	8	8	11-1-3771	29	1
11-1-1749	8	23	11-1-3904-1	9	10
11-1-1750	8	13		10	7
11-1-1751	8	15		12	16
11-1-1752	8	14		13	7
11-1-1753	8	24	11-1-3905-1	9	11
11-1-2060-1	2	1		10	2
11-1-2060-2	2	2		12	17
11-1-2060-3	2	3		13	2
11-1-2060-4	2	4	11-1-3907-1	9	16
11-1-2060-5	2	5		9	21
11-1-2061-1	2	10	11-1-3910-1	4	4
	7	1		23	2
11-1-2061-2	2	11	11-1-3910-2	6	4
	7	2	11-1-3910-3	3	6
11-1-2061-3	2	12	11-1-3922	28	1
	7	3		30	2
11-1-2061-4	2	13	11-1-3924	2	9
	7	4		6	1
11-1-2061-5	2	14	11-1-4100	9	20
	7	5	11-1-4177-1	33	3
11-1-2614	14	5	11-1-4178-1	33	5
11-1-2614-1	9	26	11-1-4179-1	33	2
	11	5	11-1-4180-1	33	1
	12	11	11-1-4259-1	33	6
11-1-2615	26	1	11-1-477	12	31
11-1-2660	11	3	11-1-478	12	24
	14	3	11-1-484-2	22	1
11-1-2666	11	2	11-1-487	12	2
	14	2	11-1-488	9	32
11-1-2669	9	29		12	3
	12	14	11-1-490	12	26
11-1-2670	9	28	11-1-491	12	25
	12	13	11-1-493	9	31
11-1-2671	9	27		12	4
	12	12	11-1-511	12	8
11-1-3359	15	1	11-1-512	12	30
11-1-3441	12	29	11-1-513	12	7
11-1-3514	12	27	11-1-562	12	34
11-1-3515	12	19	11-1-565-2	12	1
11-1-3718-1	9	13	11-1-566	12	28
	10	1	11-1-567	12	9
11-1-3718-1	12	15	11-1-7026-1	31	1
	13	1	11-1-7026-2	32	1
11-1-3719-1	10	4	11-1-721	27	1
11-1-3719-1	13	4	11-1-892	27	4
11-1-3720-1	10	6	11-1-894-1	9	25
	13	6		11	1
11-1-3721-1	10	5		12	10
	13	5		14	1

**ANCILLARY EQUIPMENT FOR LOW VELOCITY AIR DROP SYSTEMS (LVADS)  
PART NUMBER INDEX**

PART NUMBER	FIGURE	ITEM	PART NUMBER	FIGURE	ITEM
11-1-899	12	6	68F217-51	1	2
11-1-901	27	3	68F217-52	1	2
311-21643	35	5	68F217-53	1	2
311-21644	35	2	68F217-54	1	2
311-21645	35	11	68F217-55	1	2
311-21646	35	6	68F217-56	1	2
311-21647	35	7	68F217-57	1	2
311-21788	35	12	68F217-58	1	2
311-21893	35	8	68F217-59	1	2
311-80266-15	36	4	68F217-60	1	2
	54	2	68F217-61	1	2
311-80268-30	39	3	811-00414	34	2
311-80313-015	35	3		35	1
	35	4	811-00423	34	5
311-81124	35	13		42	1
311-81126	36	2	811-00429	34	1
311-81140	54	4	811-00430	46	1
311-81204	41	1	811-00444	53	1
3205A5269	34	13	811-00455	34	14
	40	1		36	1
50C7406	20	2	811-00457	34	10
50C7496	18	1		39	1
511-00695	35	9	811-00467	34	12
511-00711	37	2		43	1
53C7084-1	24	1	811-00468	34	11
53C7084-2	25	1		44	1
611-00189	55	1	811-00480	34	15
65B3650	16	7		37	1
	31	3	811-00480-1	38	1
	32	3	811-00481	34	4
65D3663	17	5		41	2
65D3820	17	1	811-00488	34	8
66B1883-1	16	6		48	1
	31	5	811-00491	54	1
66B1883-2	16	4	811-00493	52	1
	32	5	811-00494	36	3
66B1887	16	3	811-00494	39	2
67B2211-1	17	6	811-00495	51	1
67B2226	17	3	811-00496	35	10
68B1883	16	1	811-00516	49	1
68F217-2	1	3	811-00531	56	4
68F217-22	1	2	811-00534	54	3
68F217-30	1	2	811-00630	34	9
68F217-32	1	2		45	1
68F217-33	1	2	811-00631	34	6
68F217-41	1	2		50	1
68F217-45	1	2	821-00430	34	3
68F217-47	1	2	821-00457	34	7
68F217-48	1	2		47	1
68F217-49	1	2			
68F217-5	1	4			
68F217-50	1	2			



**ANCILLARY EQUIPMENT FOR LOW VELOCITY AIR DROP SYSTEM  
EXPENDABLE/DURABLE SUPPLIES AND MATERIALS LIST**

**SCOPE**

This work package lists expendable and durable items that you will need to operate and maintain the 28-Foot Diameter, Cargo Extraction Parachute. These items are authorized to you by CTA 50-970, Expendable/Durable Items (Except Medical, Class V, Repair Parts, and Heraldic Items) or CTA 8-100, Army Medical Department Expendable/Durable Items.

**EXPLANATION OF COLUMNS**

**Column 1, Item Number.** This number is assigned to the entry in the list and is referenced in the narrative instructions to identify the item (e.g., Use Cloth, Abrasive (Item 6,WP 0125 00)).

**Column 2, Level.** This column identifies the lowest level of maintenance that requires the listed item. (O = Unit Maintenance).

**Column 3, National Stock Number (NSN).** This is the NSN assigned to the item; use it to request or requisition the item.

**Column 4, Item Name, Description, Commercial and Government Entity Code (CAGEC), and Part Number (P/N).** This column provides the other information you need to identify the item.

**Column 5, Unit of Measure (U/M).** This code shows the physical measurement or count of an item, such as gallon, dozen, gross, etc.

**Table 1. Expendable/Durable Supplies and Materials List**

(1) ITEM NUMBER	(2) LEVEL	(3) NATIONAL STOCK NUMBER	(4) ITEM NAME, DESCRIPTION, CAGE, PART NUMBER	(5) UNIT OF MEASURE
1	O	7510-00-240-1525	Marker, China, White	
2	O	Local Purchase	Battery, AAA	
3	O	9160-00-253-1171	Beeswax, Technical, 1 Lb (81348) C-B-191	LB
4	O	7920-00-282-2490	Brush, Scrub Household (81348) H-B-1490	EA
5	O	7520-00-248-9285	Brush, Stenciling (81348) H-B-00621	EA
6	O	5350-00-221-0872	Cloth, Abrasive, Ferric Oxide and Quartz (81349) MIL-C-4279	EA
7	O	4020-00-240-2146	Cord, Nylon, Type III (Natural)	
8	O	4020-00-246-0688	Cord, Nylon, Type III (OD)	
9	O	5350-00-221-0872	Crocus Cloth (58536)	

Table 1. Expendable/Durable Supplies and Materials List - continued

(1) ITEM NUMBER	(2) LEVEL	(3) NATIONAL STOCK NUMBER	(4) ITEM NAME, DESCRIPTION, CAGE, PART NUMBER	(5) UNIT OF MEASURE
10	O	7930-00-281-4730	Dishwashing Compound, Hand Flake (81348) P-D-410	LB
11	O	8315-00-448-5663	Fastener Tape, Hook, 1 1/2-inch (81349) MIL-F-21840, Type II, Class 1	RL
12	O	8315-01-066-5855	Fastener Tape, Pile, 3/4-inch (81349) MIL-F-21840, Type II, Class 1	RL
13	O	5325-00-929-1824	Grommet, Metallic (96906)	
14	O	7510-00-286-5362	Ink, Marking, Parachute, Strata-Blue (81349)	PT
15	O		Kit, Refurbish, EPJD (52497)	EA
16	O	5980-01-495-2018	LED, Blue (52497) 811-00494	
17	O	5980-01-494-8721	LED, Red (52497) 811-00534	
18	O	8090-01-054-3968	Loctite, No. 222	
19	O	9150-01-132-8871	Lube, O-Ring (52497) 884-2	TU
20	O	9150-01-260-2534	Lubricant, Solid Film, MIL-L-23398	CN
21	O	7580-00-230-2734	Marker, Felt Tip, Black (81348) GG-M-0014	EA
22	O	8010-01-331-6113	Paint, Olive Drab; A-A-2787	PT
23	O	8010-01-122-1969	Paint, Yellow Enamel	CN
24	O	7520-00-491-2917	Pen, Ballpoint (81348) GG-B-0060	EA
25	O	7920-00-205-3570	Rag, Wiping (81348) DDD-R-0060	BL
26	O	9310-00-160-7858	Stencilboard, Oiled (81348) UU-S-625 Type II	SH
27	O	7510-00-053-0942	Tape, Adhesive, Pressure Sensitive	YD
28	O	4020-00-753-6555	Tape, Lacing and Tying	RO
29	O	7510-00-582-4772	Tape, Pressure Sensitive, 1-Inch (81348) PPP-T-97, Type II	RL
30	O	7510-00-053-0942	Tape, Pressure Sensitive, 1-Inch (81348) PPP-T-97, Type IV	RL
31	O	8310-00-262-2780	Thread, Nylon, Size 6, OD (81348) V-T-295	YD

**Table 1. Expendable/Durable Supplies and Materials List - continued**

(1) ITEM NUMBER	(2) LEVEL	(3) NATIONAL STOCK NUMBER	(4) ITEM NAME, DESCRIPTION, CAGE, PART NUMBER	(5) UNIT OF MEASURE
32	O	8130-00-262-2772	Thread, Nylon, Size E, OD (81348) V-T-295	YD or TU
33	O	8310-00-267-3024	Thread, Nylon, Size FF, OD (81348) V-T-295	YD
34	O	9160-00285-2044	Wax, Paraffin, Technical, Type 1, Grade A, 1 Lb (81348) VV-W-95	LB
35	O	8305-00-268-2411	Webbing, Cotton, Type I, ¼-Inch, Natural (81349) MIL-T-5661	RL
36	O	8305-00-261-8585	Webbing, Nylon, Type VIII, CG 483; PIA-W-4088	RL
37	O	8305-01-206-9219	Webbing, Nylon, Type XXVI	RL
38	O	As Applicable	Weight, 10-ounce (283 gram)	EA
39	O	Locally Manufactured	Wire, 20 Gauge	N/A
<b>END OF TABLE</b>				

**END OF WORK PACKAGE**





---

**ANCILLARY EQUIPMENT FOR LOW VELOCITY AIR DROP SYSTEMS (LVADS)  
ILLUSTRATED LIST OF MANUFACTURED ITEMS**

---

**SCOPE**

This WP includes complete instructions for making items authorized to be manufactured or fabricated at the unit maintenance level.

**How to Use the Index of Manufactured Items**

A part number index in alphanumeric order is provided for cross-referencing the part number of the item to be manufactured to the page that covers fabrication criteria.

**Explanation of the Illustrations of Manufactured Items**

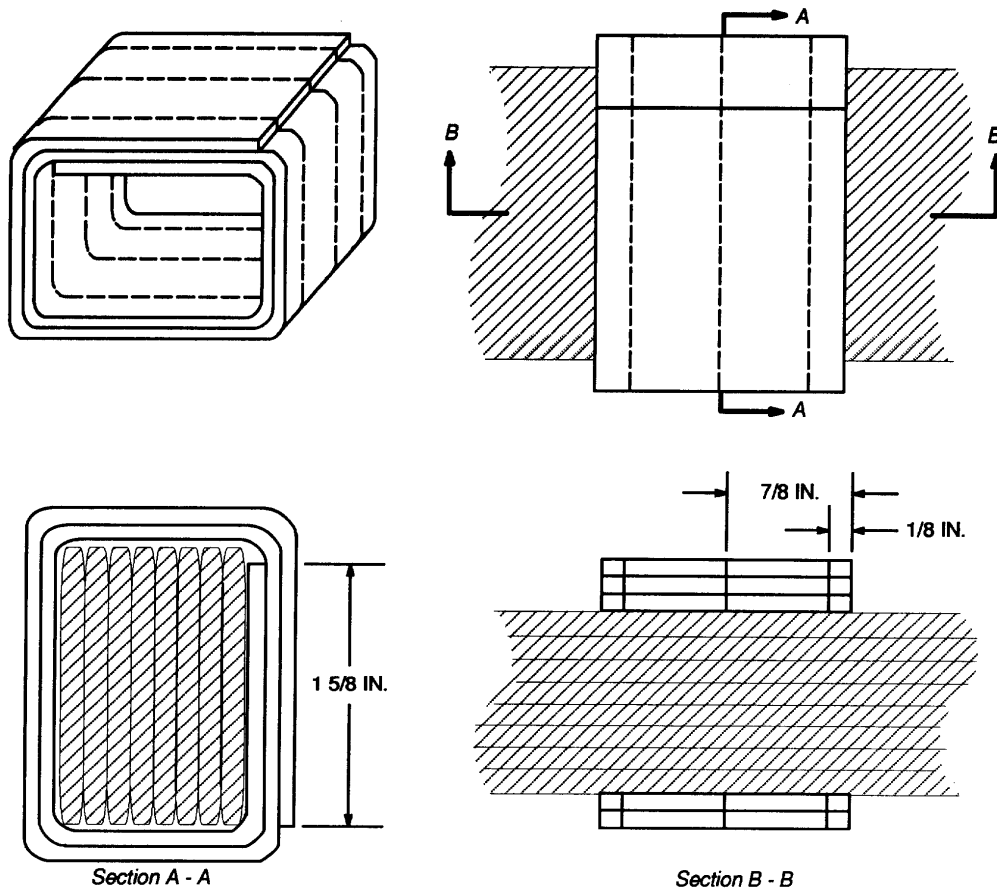
All instructions needed by maintenance personnel to manufacture the item are included on the illustrations. All bulk materials needed for manufacture of an item are listed by part number or specification number in a tabular list on the illustration.

**MANUFACTURED ITEMS PART NUMBER INDEX**

<b>Part Number</b>	<b>CAGE Code</b>	<b>Nomenclature</b>
68F217-2	81337	Keeper, Sliding
68F217-3	81337	Keeper, Fixed
68F217-5	81337	Buffer
11-1-488	81337	Lanyard, Arming Wire

ANCILLARY EQUIPMENT FOR LOW VELOCITY AIR DROP SYSTEMS (LVADS)  
ILLUSTRATED LIST OF MANUFACTURED ITEMS

SLIDING KEEPER

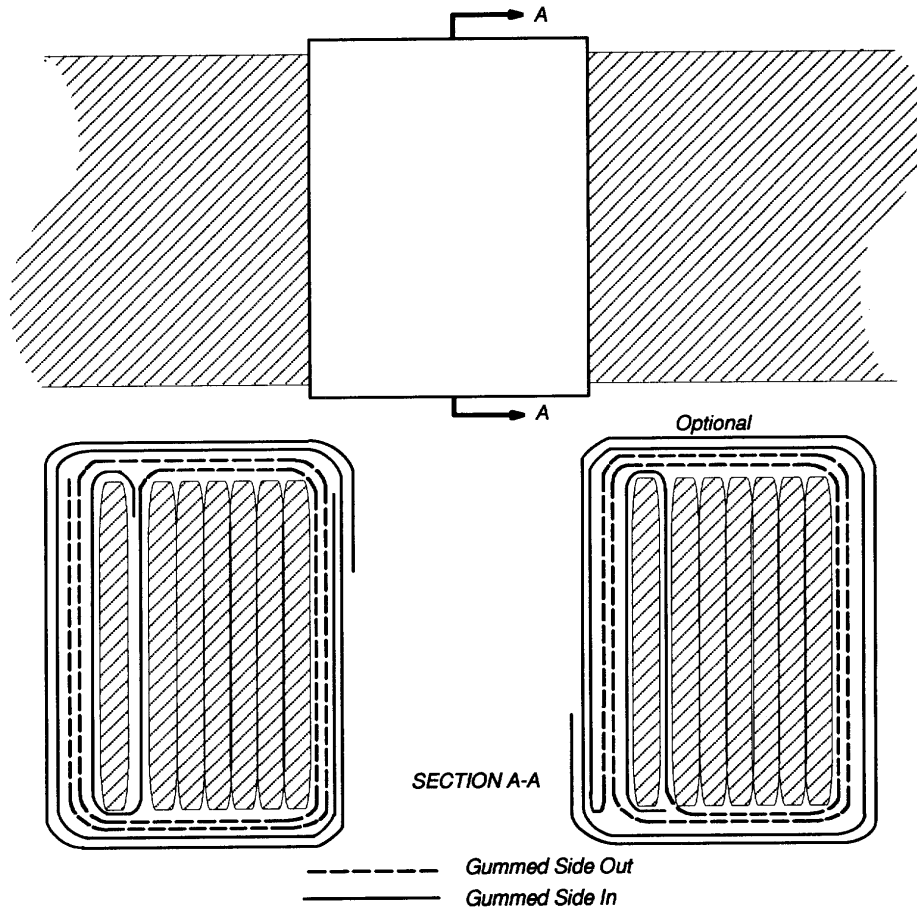


NOTES:

1. Make from nylon webbing, type VIII, class 2, color OD-7, and thread, type I, II or III, class A, color ODS-1.
2. All machine stitching to be IAW FED-STD-751 type 301, 5 to 8 stitches per inch (2 to 3 stitches per centimeter).
3. Stitch together so as to obtain as snug a fit as possible while still being large enough to sled in place onto loop with buffer stitched in place.
4. The keepers shall be stitched and shaped to the contour of the assembled line, after which they shall be dipped in a melted mixture of the 50% beeswax and 50% paraffin at a temperature of 180 +/- 20 degrees F (82 degrees +/- 11 degrees C).

**ANCILLARY EQUIPMENT FOR LOW VELOCITY AIR DROP SYSTEMS (LVADS)  
ILLUSTRATED LIST OF MANUFACTURED ITEMS**

**FIXED KEEPER**



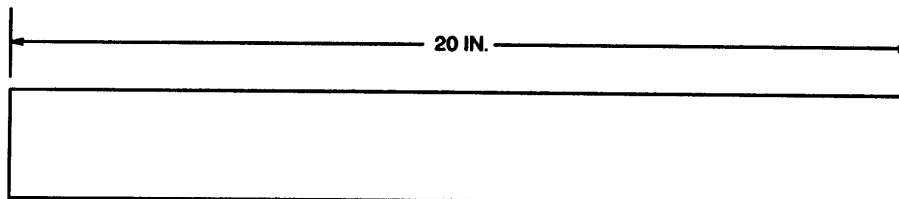
**NOTES:**

1. Use tape, pressure sensitive 1 ¼-inch (32 MM), type IV.
2. Wrap a tape strip around an outer ply with the gummed side against the webbing.
3. Wrap tape around the outside of all plies for two full turns with the gummed side away from the webbing.
4. Wrap tape in the opposite direction, two full turns with the gummed side toward the previous wraps. Cut tape.

---

**ANCILLARY EQUIPMENT FOR LOW VELOCITY AIR DROP SYSTEMS (LVADS)  
ILLUSTRATED LIST OF MANUFACTURED ITEMS**

---

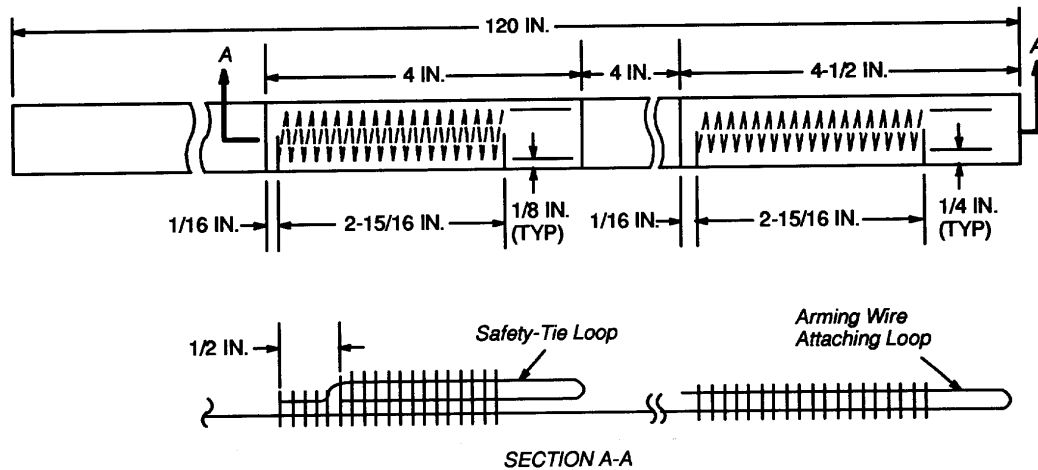
**BUFFER****NOTES:**

1. Make from nylon webbing, type XXVI, class 2, color OD-7.
2. Cut a length 20-IN. (50 CM) long.

---

**ANCILLARY EQUIPMENT FOR LOW VELOCITY AIR DROP SYSTEMS (LVADS)**  
**ILLUSTRATED LIST OF MANUFACTURED ITEMS**


---

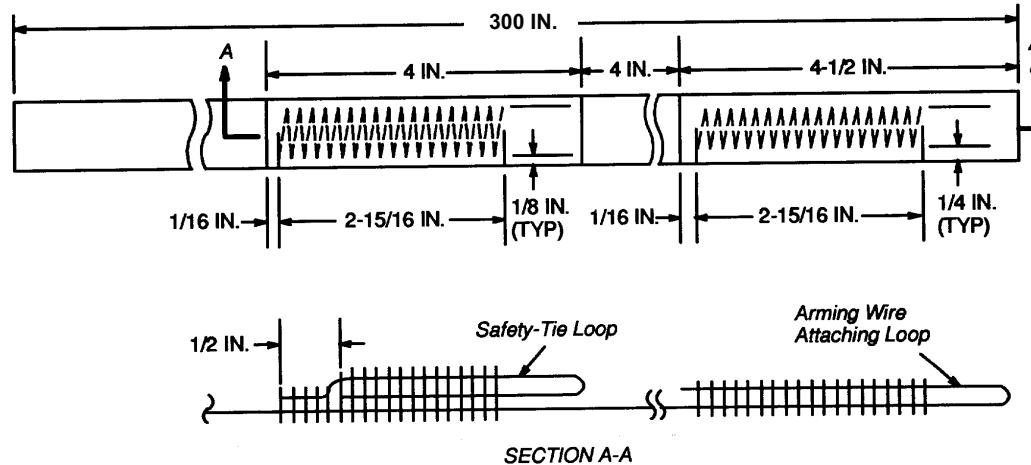
**10-FOOT ARMING WIRE LANYARD****NOTES:**

1. Make from webbing, nylon, 1/2-IN. tubular, color OD, P/N MIL-W-4088 and thread, nylon, size FF, color OD.
2. Cut a 124 1/2-IN. length and a 7 1/2-IN., length of webbing and sear the ends of both webbing lengths.
3. Mark the 124 1/2-IN. length of webbing at points 3, 4 1/2, and 13-inches from one end.
4. Form the arming wire attaching loop on the webbing length by folding the marked end of the webbing back at the 4 1/2-IN. mark.
5. Using a zig-zag sewing machine stitching 7 to 11 stitches per inch, secure the webbing fold-back. Beginning at the 3-inch mark, stitch a 2 15/16 -IN. long row of 1/4-inch-wide double throw zigzag stitching toward the fold-back seared end. End the stitch row at a point 1/6-IN. back from the fold-back seared end.
6. Mark the 7 1/2-IN. webbing length at points 3 and 4-inches from one end.
7. Form the safety tie loop by doubling the webbing length at the 4-IN. mark, allowing one end to overlap the opposite end by 1/2-IN.
8. Position the folded 7 1/2-IN. webbing length on the 124 1/2-IN. webbing length with the 3-IN. long end of the folded webbing face-down and the folded end aligned with the 13-IN. mark made in step 2., above.
9. Beginning at the 3-IN. mark, secure the folded webbing length by stitching as outlined in step 5., above.

---

**ANCILLARY EQUIPMENT FOR LOW VELOCITY AIR DROP SYSTEMS (LVADS)**  
**ILLUSTRATED LIST OF MANUFACTURED ITEMS**


---

**25-FOOT ARMING WIRE LANYARD**

**NOTES:**

1. Make from webbing, nylon, 1/2-IN. tubular, color OD, P/N MIL-W-4088 and thread, nylon, size FF, color OD.
2. Cut a 304 1/2-IN. length and a 7 1/2-IN., length of webbing and sear the ends of both webbing lengths.
3. Mark the 304 1/2-IN. length of webbing at points 3, 4 1/2, and 13-inches from one end.
4. Form the arming wire attaching loop on the webbing length by folding the marked end of the webbing back at the 4 1/2-IN. mark.
5. Using a zigzag sewing machine stitching 7 to 11 stitches per inch, secure the webbing fold-back. Beginning at the 3-IN. mark, stitch a 2 15/16 -IN. long row of 1/4-inch-wide double throw zig-zag stitching toward the fold-back seared end. End the stitch row at a point 1/6-IN. back from the fold-back seared end.
6. Mark the 7 1/2-IN. webbing length at points 3 and 4-inches from one end.
7. Form the safety tie loop by doubling the webbing length at the 4-IN. mark, allowing one end to overlap the opposite end by 1/2-IN.
8. Position the folded 7 1/2-IN webbing length on the 304 1/2-IN. webbing length with the 3-IN. long end of the folded webbing face-down and the folded end aligned with the 13-IN. mark made in step 2., above.
9. Beginning at the 3-IN. mark, secure the folded webbing length by stitching as outlined in step 5., above.

**END OF WORK PACKAGE**

**ANCILLARY EQUIPMENT FOR LOW VELOCITY AIR DROP SYSTEMS (LVADS)  
TORQUE LIMITS**

**SCOPE**

This work package provides torque limits for general use fasteners. The torque values given in this work package shall be used when specific torque values are not identified in the maintenance instructions.

**TORQUE LIMITS**

All figures provided in table 1 are foot-pounds except those marked with an asterick (\*), which are inch-pounds. There is no difference between torque figures for fine or course threads. The torque figure for finely threaded fasteners as compared to coarsely threaded fasteners of the same diameter may be slightly higher.

**Table 1. Torque Limits**

Type	Minimum Tensile Strength	Material	Body Size or Outside Diameter of Fastener													
			1/16	1/10	1/8	1/4	5/16	3/8	1/2	3/4	7/8	1	1 1/8	1 1/4	1 3/8	1 1/2
SAE 0-1-2	74,000 PSI	Low Carbon Steel	32	12	20	6	69	99	47	155	206	210	460	675	900	1100
SAE 3	100,000 PSI	Medium Carbon Steel	47	17	30	9	103	145	69	234	372	551	872	1211	1624	1943
SAE 5	120,000 PSI	Medium Carbon Heat Treat Steel	54	19	33	10	114	154	78	257	382	587	794	1105	1500	1775
SAE 6	133,000 PSI	Medium Carbon Steel Quenched Tempered	69	24	43	125	150	209	106	350	550	825	1304	1815	2434	2913
SAE 7	133,000 PSI	Medium Carbon Steel	71	25	44	13	154	215	110	360	570	840	1325	1825	2500	3000
SAE 8	150,000 PSI	Medium Carbon Alloy Steel	78	29	47	14	169	230	119	380	600	900	1430	1975	2650	3200
Socket Head Cap Screw	160,000 PSI	High Carbon Case Hardened Steel	84	33	54	16	180	250	125	400	640	970	1520	2130	2850	3450
Socket Set Screw	212,000 PSI	High Carbon Case Hardened Steel	29	140*	18	70*	63	100	43	146						
Machine Screw Yellow Brass	60,000 PSI	Copper (CU) 63% Zinc (ZU) 37%	27	110*	17	65*	49	78	37	104	160	215	325	400		595
Silicone Bronze Type B	70,000 PSI	Copper (CU) 96% Zinc (ZU) 2% Silicon (SI) 2%	30	125*	20	70*	53	88	41	117	180	250	365	450		655

**ANCILLARY EQUIPMENT FOR LOW VELOCITY AIR DROP SYSTEMS (LVADS)  
TORQUE LIMITS**

**Table 1. Torque Limits – continued**

Type	Minimum Tensile Strength	Material	Body Size or Outside Diameter of Fastener												
			1 <sup>5</sup> / <sub>8</sub>	1 <sup>3</sup> / <sub>4</sub>	1 <sup>7</sup> / <sub>8</sub>	2	2 <sup>1</sup> / <sub>4</sub>	2 <sup>1</sup> / <sub>2</sub>	2 <sup>3</sup> / <sub>4</sub>	3	4	5	6	7	10
SAE 0-1-2	74,000 PSI	Low Carbon Steel	1470	1900	2360	2750	3450	4400	7350	9500					
SAE 3	100,000 PSI	Medium Carbon Steel	2660	3463	4695	5427	7226	8049	13450	17548					
SAE 5	120,000 PSI	Medium Carbon Heat Treat Steel	2425	3150	4200	4550	6550	7175	13000	16000					
SAE 6	133,000 PSI	Medium Carbon Steel Quenched Tempered	3985	5189	6980	7491	10825	14983	20151	26286					
SAE 7	133,000 PSI	Medium Carbon Steel	4000	5300	7000	7500	11000	15500	21000	27000					
SAE 8	150,000 PSI	Medium Carbon Alloy Steel	4400	5650	7600	8200	12000	17000	23000	29000					
Socket Head Cap Screw	160,000 PSI	High Carbon Case Hardened Steel	4700	6100	8200	8800	13000	18000	24000	31000					
Socket Set Screw	212,000 PSI	High Carbon Case Hardened Steel											9*	18*	30*
Machine Screw Yellow Brass	60,000 PSI	Copper (CU) 63% Zinc (ZU) 37%				2*				33*	44*	64*	8*	16*	20*
Silicone Bronze Type B	70,000 PSI	Copper (CU) 96% Zinc (ZU) 2% Silicon (SI) 2%				2.3*				37*	49*	72*	10*	19*	22*

END OF WORK PACKAGE



## ALPHABETICAL INDEX

**Subject**

**WP Sequence No. – Page No.**

**A**

Accomplishing a Log Record .....	0003 00-4
Acronyms and Abbreviations .....	0001 00-4
Aerial Delivery Clevis .....	0028 00-1
Air Force Technical Order Forms.....	0063 00-3
Aircraft Cargo Tie-Down.....	0039 00-1
Army Regulations.....	0063 00-2

**B**

Basting and Temporary Tacking .....	0010 00-1
-------------------------------------	-----------

**C**

Checking Unpacked Equipment .....	0003 00-2
Cleaning Agents.....	0004 00-5
Cleaning and Drying.....	0008 00-1
Cleaning Fabric Items With A Solution of Hand Dishwashing Compound .....	0008 00-1
Cleaning Metal Items .....	0008 00-2
Clevis Cover.....	0029 00-1
Common Name .....	0001 00-4
Common Tools and Equipment .....	0001 00-5
Control Box .....	0047 00-1
Corrosion Prevention And Control (CPC) .....	0001 00-2

**D**

Destruction Of Army Materiel To Prevent Enemy Use .....	0001 00-2
Drop Testing Procedures .....	0004 00-3
Drying Fabric Items .....	0008 00-2

**E**

Equipment Characteristics, Capabilities, And Features.....	0002 00-1
Equipment Description and Data .....	0002 00-1
Equipment Disposition .....	0007 00-3
Equipment Improvements and Recommendations, Reporting (EIR).....	0001 00-2
Equipment Name .....	0001 00-1
Expendable/Durable Supplies and Materials List .....	0125 00-1
Extraction Force Transfer Coupling Adapter Link Assembly .....	0014 00-1
Extraction Force Transfer Coupling .....	0013 00-1

Subject

WP Sequence No. – Page No.

**E - Continued**

Extraction Force Transfer Coupling 3-Point Adapter Link Assembly .....0015 00-1  
 Extraction Force Transfer Coupling Actuator Assembly .....0019 00-1  
 Extraction Force Transfer Coupling Cable Assembly .....0018 00-1  
 Extraction Force Transfer Coupling Connector Latch Assembly .....0016 00-1  
 Extraction Force Transfer Coupling Latch Assembly Coupling .....0017 00-1  
 Extraction Parachute Jettison Device (EPJD), Squib, and Squib Cable .....0044 00-1  
 Extraction Parachute Jettison System (EPJS).....0043 00-1

**F**

1-Foot Power Cable Adapter (C-5 only).....0056 00-1  
 10-Foot Interconnect Cable.....0049 00-1  
 20-Foot Power Cable .....0051 00-1  
 20-Foot Power Cable Extension (C-17 only) .....0055 00-1  
 50-Foot Main Cable.....0050 00-1  
 Forms .....0063 00-3  
 Field Manuals.....0063 00-2

**G**

General Information .....0001 00-1  
 General Procedures for Air Delivery Equipment.....0003 00-1

**H**

Heavy-Duty Link Assembly .....0025 00-1  
 How to Use This Manual ..... v

**I**

3 3/4-Inch, 2-Point Link .....0040 00-1  
 5 1/2-Inch, 2-Point Link .....0041 00-1  
 Illustrated List of Manufactured Items .....0126 00-1  
 Initial Receipt.....0003 00-1  
 Initiator Simulator .....0058 00-1  
 Inspection Personnel .....0003 00-1  
 Inspection.....0007-00-1  
 Installing Attaching Tie .....0003 00-3

**J**

Jump, Inspection, and Repack Data Page.....0003 00-7

**Subject**

**WP Sequence No. – Page No.**

**K**

10K Cargo Tie-Down.....0036 00-1  
 Kit Bag .....0053 00-1

**L**

List of Acronyms and Abbreviations.....0001 00-4  
 List of Effective Pages.....A  
 Location And Description of Major Components.....0002 00-1

**M**

M-1 Cargo Parachute Release .....0020 00-1  
 M-2 Cargo Parachute Release .....0021 00-1  
 M-35 Suspension Bracket.....0033 00-1  
 M-59 Suspension Bracket.....0034 00-1  
 Maintenance Allocation Chart (MAC).....0064 00-1  
 Maintenance Allocation Chart (MAC), Table 1.....0064 00-3  
 Maintenance Allocation Chart (MAC), Table 2.....0064 00-8  
 Maintenance Allocation Chart (MAC), Table 3.....0064 00-11  
 Maintenance Forms, Forms, Records and Reports.....0001 00-2  
 Marine Corps Forms .....0063 00-3  
 Marking, Restencilling and Repainting.....0011 00-1  
 Modification Work Order (MWO) Compliance Record Page .....0003 00-6  
 Multi-Knife Parachute Release Strap.....0031 00-1  
 Multi-Loop Line.....0012 00-1

**N**

National Stock Number (NSN) Index .....0123 00-1  
 Nomenclature Cross-Reference List.....0001 00-4

**P**

3-Point Coupling Link Assembly Coupling .....0032 00-1  
 4-Point Link .....0026 00-1  
 Parachute Connector .....0022 00-1  
 Parachute Connector Link .....0120 01-1  
 Parachute Log Record .....0003 00-2  
 Part Number and Equipment Name.....0001 00-1  
 Part Number Index .....0124 00-1  
 Platform Cable (All)/4-Foot Extension Cable (C-5 and C-17 only) .....0048 00-1  
 Preparation for Shipment .....0062 00-1  
 Preparation for Storage.....0061 00-1  
 Preventive Maintenance Checks and Services (PMCS), After Procedures .....0006 00-1  
 Preventive Maintenance Checks and Services (PMCS), Before Procedures .....0005 00-1  
 Preventive Maintenance Checks and Services (PMCS), Introduction .....0004 00-1  
 Processing Unpacked Equipment.....0003 00-2  
 Protective Cover.....0052 00-1  
 Purpose of Equipment.....0001 00-1

**Q**

Quick-Release Cargo Tie-Down ..... 0037 00-1

**R**

References ..... 0063 00-1

- Air Force Technical Order Forms ..... 0063 00-3
- Air Force Technical Orders ..... 0063 00-3
- Army Regulations ..... 0063 00-2
- Field Manuals ..... 0063 00-2
- Forms ..... 0063 00-3
- Marine Corps Forms ..... 0063 00-3
- Miscellaneous ..... 0063 00-2
- Pamphlets ..... 0063 00-1
- Publication Indexes ..... 0063 00-1
- Technical Bulletins ..... 0063 00-3
- Technical Manuals ..... 0063 00-1

Release Away Static Line Assembly ..... 0042 00-1

Repair Parts and Special Tools List (RPSTL), Introduction ..... 0065 00-1

Repair Parts List

- Group 01 Multi-Loop Line ..... 0066 00-2
- Group 02 Extraction Force Transfer Coupling ..... 0067 00-2
- Group 0201 Extraction Force Transfer Coupling Adapter Link Assembly ..... 0068 00-2
- Group 0202 EFTC 3-Point Coupling Link Assembly ..... 0069 00-2
- Group 0203 EFTC Connector Latch Assembly Coupling ..... 0070 00-2
- Group 0204 Connector Latch Assembly ..... 0071 00-2
- Group 0205 Coupling Cable Assembly ..... 0072 00-2
- Group 0206 Actuator Assembly ..... 0073 00-2
- Group 03 M-1 Cargo Parachute Release ..... 0074 00-2
- Group 0301 Parachute Connector ..... 0075 00-2
- Group 0302 Timer Delay Assembly ..... 0076 00-2
- Group 04 M-2 Cargo Parachute Release ..... 0077 00-2
- Group 0401 Parachute Connector ..... 0078 00-2
- Group 0402 Timer Delay Assembly ..... 0079 00-2
- Group 05 Type IV Single Suspension Link Assembly ..... 0080 00-1
- Group 0501 Heavy-Duty Link Assembly ..... 0081 00-2
- Group 0502 4-Point Link ..... 0082 00-2
- Group 0503 Type IV Link Cover ..... 0083 00-1
- Group 0504 Aerial Delivery Clevis ..... 0084 00-2
- Group 0505 Clevis Cover ..... 0085 00-1
- Group 0506 Single Knife Parachute Release Strap ..... 0086 00-1
- Group 0507 Multi-Knife Parachute Release Strap ..... 0087 00-1
- Group 0508 3-Point Coupling Link Assembly ..... 0088 00-2
- Group 0509 M-35 Suspension Bracket ..... 0089 00-1
- Group 0510 M-59 Suspension Bracket ..... 0090 00-1
- Group 0511 Suspension Plate ..... 0091 00-1
- Group 0512 10K Cargo Tie-Down ..... 0092 00-1
- Group 0513 Quick-Release Cargo Tie-Down ..... 0093 00-1
- Group 0514 Type IV Drive-Off Aid ..... 0094 00-1
- Group 0515 Aircraft Cargo Tie-Down ..... 0095 00-1
- Group 0516 3 ¾-IN., 2-Point Link ..... 0096 00-2
- Group 0517 5 ½-IN., 2-Point Link ..... 0097 00-2

Subject

WP Sequence No. – Page No.

**R- Continued**

Group 0518 Release Away Static Line Assembly .....0098 00-2  
 Group 06 Extraction Parachute Jettison System (EPJS) .....0099 00-2  
 Group 0601 Extraction Parachute Jettison Device (EPJD) .....0100 00-2  
 Group 0602 Y-Connector.....0101 00-2  
 Group 0603 Y-Connector Mounting Box (C-130; C-141; C-17) .....0102 00-1  
 Group 0604 Y-Connector Mounting Box (C-5) .....0103 00-1  
 Group 0605 Control Box .....0104 00-1  
 Group 0606 Squib Assembly .....0105 00-1  
 Group 0607 EPJS Squib Cable .....0106 00-1  
 Group 0608 10-Foot Platform Cable.....0107 00-1  
 Group 0609 10-Foot Interconnect Cable .....0108 00-1  
 Group 0610 50-Foot Main Cable .....0109 00-1  
 Group 0611 20-Foot Power Cable.....0110 00-1  
 Group 0612 Protective Cover .....0111 00-1  
 Group 0613 Kit Bag .....0112 00-1  
 Group 0614 4-Foot Extension Cable (C-5 and C-17) .....0113 00-1  
 Group 0615 Y-Connector Mounting Box Tie-Down Bracket (C-5) .....0114 00-1  
 Group 0616 20-Foot Power Cable Extension (C-17 Only) .....0115 00-1  
 Group 0617 1-Foot Power Cable Adapter (C-5).....0116 00-1  
 Group 0618 Safety Cap .....0117 00-1  
 Group 0619 Initiator Simulator .....0118 00-1  
 Group 0620 Squib Tester .....0119 00-1  
 Group 0621 28 VDC Power Supply .....0120 00-1  
 Group 07 Parachute Connector Link.....0120 01-1  
 Group 90 Bulk Materials .....0121 00-1  
 Group 95 Special Tools .....0122 00-1  
 Reporting Equipment Improvement Recommendations (EIR) .....0001 00-2  
 Rinsing Equipment Immersed in Fresh-Water .....0008 00-4  
 Rinsing Equipment Immersed in Salt-Water .....0008 00-3  
 Routine Inspection .....0007 00-2

**S**

Safety Cap .....0057 00-1  
 Safety, Care and Handling .....0001 00-5  
 Salt-/Fresh Water Contamination Test.....0009 00-1  
 Service Upon Receipt .....0003 00-1  
 Sewing Machine Code Symbols, Table 1 .....0010 00-2  
 Sewing Procedures .....0010 00-1  
 Single Knife Parachute Release Strap.....0030 00-1  
 Special Tools, TMDE and Support Equipment .....0001 00-5  
 Squib Tester.....0059 00-1  
 Suspension Plate .....0035 00-1

**T**

Table of Contents .....ii  
 Technical Bulletins .....0063 00-3  
 Technical Manuals .....0063 00-1  
 Timer Delay Assembly .....0023 00-1  
 Torque Limits .....0127 00-1

**Subject**

**WP Sequence No. – Page No.**

**T - Continued**

Type IV Drive Off Aid .....0038 00-1  
Type IV Link Cover.....0027 00-1  
Type IV Single Suspension Link Assembly.....0024 00-1

**V**

28 VDC Power Supply .....0060 00-1

**W**

Warning Summary ..... a  
Warranty Information.....0001 00-3

**Y**

Y-Connector .....0045 00-1  
Y-Connector Mounting Box (C-130, C-141, C-17, C-5).....0046 00-1  
Y-Connector Mounting Box Tie-Down Bracket (C-5).....0054 00-1

**TM 10-1670-296-20&P**

By Order of the Secretaries of the Army and the Air Force:

Official:



JOEL B. HUDSON

*Administrative Assistant to the  
Secretary of the Army*

0228307

ERIC K. SHINSEKI  
*General, United States Army  
Chief of Staff*

**DISTRIBUTION:**

To be distributed in accordance with Initial Distribution Number (IDN) 256283, requirements for TM 10-1670-296-20&P.





## ***These are the instructions for sending an electronic 2028***

The following format must be used if submitting an electronic 2028. The subject line must be exactly the same and all fields must be included; however only the following fields are mandatory: 1, 3, 4, 5, 6, 7, 8, 9, 10, 13, 15, 16, 17, and 27.

From: "Whomever" <whomever@avma27.army.mil>

To: amssbriml@natick.army.mil

Subject: DA Form 2028

1. **From:** Joe Smith
2. **Unit:** home
3. **Address:** 4300 Park
4. **City:** Hometown
5. **St:** MO
6. **Zip:** 77777
7. **Date Sent:** 19-OCT-93
8. **Pub no:** 55-2840-229-23
9. **Pub Title:** TM
10. **Publication Date:** 04-JUL-85
11. **Change Number:** 7
12. **Submitter Rank:** MSG
13. **Submitter FName:** Joe
14. **Submitter MName:** T
15. **Submitter LName:** Smith
16. **Submitter Phone:** 123-123-1234
17. **Problem:** 1
18. **Page:** 2
19. **Paragraph:** 3
20. **Line:** 4
21. **NSN:** 5
22. **Reference:** 6
23. **Figure:** 7
24. **Table:** 8
25. **Item:** 9
26. **Total:** 123
27. **Text:**

This is the text for the problem below line 27.



<b>RECOMMENDED CHANGES TO PUBLICATIONS AND BLANK FORMS</b> For use of this form, see AR 25-30; the proponent agency is ODISC4.						Use Part II (reverse) for Repair Parts and Special Tool Lists (RPSTL) and Supply Catalogs/Supply Manuals (SC/SM).	<b>DATE</b> <i>21 October 2003</i>
<b>TO:</b> (Forward to proponent of publication or form) (Include ZIP Code) COMMANDER U.S. ARMY TANK-AUTOMOTIVE AND ARMAMENT COMMAND ATTN: AMSTA-LC-CECT 15 KANSAS STREET NATICK, MA 01760-5052						<b>FROM:</b> (Activity and location) (Include ZIP Code)  <i>PFC Jane Doe          CO A 3<sup>rd</sup> Engineer BR          Ft. Leonardwood, MO 63108</i>	
<b>PART I – ALL PUBLICATIONS (EXCEPT RPSTL AND SC/SM) AND BLANK FORMS</b>							
<b>PUBLICATION/FORM NUMBER</b> TM 10-1670-296-23&P				<b>DATE</b> 30 October 2002	<b>TITLE</b> Ancillary Equipment for Low Velocity Air Drop Systems		
<b>ITEM NO.</b>	<b>PAGE NO.</b>	<b>PARA-GRAPH</b>	<b>LINE NO. *</b>	<b>FIGURE NO.</b>	<b>TABLE NO.</b>	<b>RECOMMENDED CHANGES AND REASON</b> <i>(Provide exact wording of recommended changes, if possible).</i>	
	0036 00-2				1	<i>In table 1, Sewing Machine Code Symbols, the second sewing machine code symbol should be MD ZZ not MD 22.</i>  <i>Change the manual to show Sewing Machine, Industrial: Zig-Zag; 308 stitch; medium-duty; NSN 3530-01-181-1421 as a MD ZZ code symbol.</i>	
<i>*Reference to line numbers within the paragraph or subparagraph.</i>							
<b>TYPED NAME, GRADE OR TITLE</b>  Jane Doe, PFC				<b>TELEPHONE EXCHANGE/AUTOVON, PLUS EXTENSION</b>  508-233-4141		<b>SIGNATURE</b>  Jane Doe <i>Jane Doe</i>	

<b>TO:</b> <i>(Forward direct to addressee listed in publication)</i> COMMANDER U.S. ARMY TANK-AUTOMOTIVE AND ARMAMENT COMMAND ATTN: AMSTA-LC-CECT 15 KANSAS STREET NATICK, MA 01760-5052	<b>FROM:</b> <i>(Activity and location) (Include ZIP Code)</i> <i>PFC Jane Doe</i> <i>CO A 3<sup>rd</sup> Engineer BR</i> <i>Ft. Leonardwood, MO 63108</i>	<b>DATE</b> 21 October 2003
----------------------------------------------------------------------------------------------------------------------------------------------------------------------------------------------------------	---------------------------------------------------------------------------------------------------------------------------------------------------------------------	--------------------------------

**PART II – REPAIR PARTS AND SPECIAL TOOL LISTS AND SUPPLY CATALOGS/SUPPLY MANUALS**

<b>PUBLICATION NUMBER</b> TM 10-1670-296-23&P	<b>DATE</b> 30 October 2002	<b>TITLE</b> Ancillary Equipment for Low Velocity Air Drop Systems
--------------------------------------------------	--------------------------------	-----------------------------------------------------------------------

PAGE NO.	COLM NO.	LINE NO.	NATIONAL STOCK NUMBER	REFERENCE NO.	FIGURE NO.	ITEM NO.	TOTAL NO. OF MAJOR ITEMS SUPPORTED	RECOMMENDED ACTION
0066 00-1					4			<i>Callout 16 in figure 4 is pointed to a <u>D-Ring</u>. In the Repair Parts List key for figure 4, item 16 is called a <u>Snap Hook</u>. Please correct one or the other.</i>

SAMPLE

**PART III – REMARKS** *(Any general remarks or recommendations, or suggestions for improvement of publications and blank forms. Additional blank sheets may be used if more space is needed.)*

TYPED NAME, GRADE OR TITLE	TELEPHONE EXCHANGE/AUTOVON, PLUS EXTENSION	SIGNATURE
----------------------------	--------------------------------------------	-----------

<b>RECOMMENDED CHANGES TO PUBLICATIONS AND BLANK FORMS</b>						Use Part II (reverse) for Repair Parts and Special Tool Lists (RPSTL) and Supply Catalogs/Supply Manuals (SC/SM).	DATE
For use of this form, see AR 25-30; the proponent agency is ODISC4.							
<b>TO:</b> (Forward to proponent of publication or form) (Include ZIP Code) COMMANDER U.S. ARMY TANK-AUTOMOTIVE AND ARMAMENT COMMAND ATTN:AMSTA-LC-CECT 15 KANSAS STREET NATICK, MA 01760-5052						<b>FROM:</b> (Activity and location) (Include ZIP Code)	
<b>PART I – ALL PUBLICATIONS (EXCEPT RPSTL AND SC/SM) AND BLANK FORMS</b>							
PUBLICATION/FORM NUMBER TM 10-1670-296-20&P				DATE 30 October 2002	TITLE ANCILLARY EQUIPMENT FOR LOW VELOCITY AIR DROP SYSTEM (LVADS)		
ITEM NO.	PAGE NO.	PARA- GRAPH	LINE NO. *	FIGURE NO.	TABLE NO.	RECOMMENDED CHANGES AND REASON <i>(Provide exact wording of recommended changes, if possible).</i>	
<i>*Reference to line numbers within the paragraph or subparagraph.</i>							
TYPED NAME, GRADE OR TITLE				TELEPHONE EXCHANGE/AUTOVON, PLUS EXTENSION		SIGNATURE	

<b>TO:</b> <i>(Forward direct to addressee listed in publication)</i> COMMANDER U.S. ARMY TANK-AUTOMOTIVE AND ARMAMENT COMMAND ATTN:AMSTA-LC-CECT 15 KANSAS STREET NATICK, MA 01760-5052	<b>FROM:</b> <i>(Activity and location) (Include ZIP Code)</i>	<b>DATE</b>
---------------------------------------------------------------------------------------------------------------------------------------------------------------------------------------------------------	----------------------------------------------------------------	-------------

**PART II – REPAIR PARTS AND SPECIAL TOOL LISTS AND SUPPLY CATALOGS/SUPPLY MANUALS**

PUBLICATION NUMBER TM 10-1670-296-20&P	DATE 30 October 2002	TITLE ANCILLARY EQUIPMENT FOR LOW VELOCITY AIR DROP SYSTEM (LVADS)
-------------------------------------------	-------------------------	--------------------------------------------------------------------------

PAGE NO.	COLM NO.	LINE NO.	NATIONAL STOCK NUMBER	REFERENCE NO.	FIGURE NO.	ITEM NO.	TOTAL NO. OF MAJOR ITEMS SUPPORTED	RECOMMENDED ACTION

**PART III – REMARKS** *(Any general remarks or recommendations, or suggestions for improvement of publications and blank forms. Additional blank sheets may be used if more space is needed.)*

TYPED NAME, GRADE OR TITLE	TELEPHONE EXCHANGE/AUTOVON, PLUS EXTENSION	SIGNATURE
----------------------------	--------------------------------------------	-----------

<p align="center"><b>RECOMMENDED CHANGES TO PUBLICATIONS AND BLANK FORMS</b></p> <p>For use of this form, see AR 25-30; the proponent agency is ODISC4.</p>						Use Part II (reverse) for Repair Parts and Special Tool Lists (RPSTL) and Supply Catalogs/Supply Manuals (SC/SM).	DATE
<b>TO:</b> (Forward to proponent of publication or form) (Include ZIP Code) COMMANDER U.S. ARMY TANK-AUTOMOTIVE AND ARMAMENT COMMAND ATTN:AMSTA-LC-CECT 15 KANSAS STREET NATICK, MA 01760-5052						<b>FROM:</b> (Activity and location) (Include ZIP Code)	
<b>PART I – ALL PUBLICATIONS (EXCEPT RPSTL AND SC/SM) AND BLANK FORMS</b>							
PUBLICATION/FORM NUMBER TM 10-1670-296-20&P						DATE 30 October 2002	TITLE ANCILLARY EQUIPMENT FOR LOW VELOCITY AIR DROP SYSTEM (LVADS)
ITEM NO.	PAGE NO.	PARA-GRAPH	LINE NO. *	FIGURE NO.	TABLE NO.	RECOMMENDED CHANGES AND REASON <i>(Provide exact wording of recommended changes, if possible).</i>	
<i>*Reference to line numbers within the paragraph or subparagraph.</i>							
TYPED NAME, GRADE OR TITLE				TELEPHONE EXCHANGE/AUTOVON, PLUS EXTENSION		SIGNATURE	

<b>TO:</b> <i>(Forward direct to addressee listed in publication)</i> COMMANDER U.S. ARMY TANK-AUTOMOTIVE AND ARMAMENT COMMAND ATTN:AMSTA-LC-CECT 15 KANSAS STREET NATICK, MA 01760-5052	<b>FROM:</b> <i>(Activity and location) (Include ZIP Code)</i>	<b>DATE</b>
---------------------------------------------------------------------------------------------------------------------------------------------------------------------------------------------------------	----------------------------------------------------------------	-------------

**PART II – REPAIR PARTS AND SPECIAL TOOL LISTS AND SUPPLY CATALOGS/SUPPLY MANUALS**

PUBLICATION NUMBER TM 10-1670-296-20&P	DATE 30 October 2002	TITLE ANCILLARY EQUIPMENT FOR LOW VELOCITY AIR DROP SYSTEM (LVADS)
-------------------------------------------	-------------------------	-----------------------------------------------------------------------

PAGE NO.	COLM NO.	LINE NO.	NATIONAL STOCK NUMBER	REFERENCE NO.	FIGURE NO.	ITEM NO.	TOTAL NO. OF MAJOR ITEMS SUPPORTED	RECOMMENDED ACTION

**PART III – REMARKS** *(Any general remarks or recommendations, or suggestions for improvement of publications and blank forms. Additional blank sheets may be used if more space is needed.)*

TYPED NAME, GRADE OR TITLE	TELEPHONE EXCHANGE/AUTOVON, PLUS EXTENSION	SIGNATURE
----------------------------	--------------------------------------------	-----------



<b>RECOMMENDED CHANGES TO PUBLICATIONS AND BLANK FORMS</b>						Use Part II (reverse) for Repair Parts and Special Tool Lists (RPSTL) and Supply Catalogs/Supply Manuals (SC/SM).	DATE
For use of this form, see AR 25-30; the proponent agency is ODISC4.							
<b>TO:</b> (Forward to proponent of publication or form) (Include ZIP Code) COMMANDER U.S. ARMY TANK-AUTOMOTIVE AND ARMAMENT COMMAND ATTN:AMSTA-LC-CECT 15 KANSAS STREET NATICK, MA 01760-5052						<b>FROM:</b> (Activity and location) (Include ZIP Code)	
<b>PART I – ALL PUBLICATIONS (EXCEPT RPSTL AND SC/SM) AND BLANK FORMS</b>							
PUBLICATION/FORM NUMBER TM 10-1670-296-20&P				DATE 30 October 2002	TITLE ANCILLARY EQUIPMENT FOR LOW VELOCITY AIR DROP SYSTEM (LVADS)		
ITEM NO.	PAGE NO.	PARA- GRAPH	LINE NO. *	FIGURE NO.	TABLE NO.	RECOMMENDED CHANGES AND REASON <i>(Provide exact wording of recommended changes, if possible).</i>	
<i>*Reference to line numbers within the paragraph or subparagraph.</i>							
TYPED NAME, GRADE OR TITLE				TELEPHONE EXCHANGE/AUTOVON, PLUS EXTENSION		SIGNATURE	

<b>TO:</b> <i>(Forward direct to addressee listed in publication)</i> COMMANDER U.S. ARMY TANK-AUTOMOTIVE AND ARMAMENT COMMAND ATTN:AMSTA-LC-CECT 15 KANSAS STREET NATICK, MA 01760-5052	<b>FROM:</b> <i>(Activity and location) (Include ZIP Code)</i>	<b>DATE</b>
---------------------------------------------------------------------------------------------------------------------------------------------------------------------------------------------------------	----------------------------------------------------------------	-------------

**PART II – REPAIR PARTS AND SPECIAL TOOL LISTS AND SUPPLY CATALOGS/SUPPLY MANUALS**

PUBLICATION NUMBER TM 10-1670-296-20&P	DATE 30 October 2002	TITLE ANCILLARY EQUIPMENT FOR LOW VELOCITY AIR DROP SYSTEM (LVADS)
-------------------------------------------	-------------------------	--------------------------------------------------------------------------

PAGE NO.	COLM NO.	LINE NO.	NATIONAL STOCK NUMBER	REFERENCE NO.	FIGURE NO.	ITEM NO.	TOTAL NO. OF MAJOR ITEMS SUPPORTED	RECOMMENDED ACTION

**PART III – REMARKS** *(Any general remarks or recommendations, or suggestions for improvement of publications and blank forms. Additional blank sheets may be used if more space is needed.)*

TYPED NAME, GRADE OR TITLE	TELEPHONE EXCHANGE/AUTOVON, PLUS EXTENSION	SIGNATURE
----------------------------	--------------------------------------------	-----------

## The Metric System and Equivalents

### *Linear Measure*

1 centimeter = 10 millimeters = .39 inch  
 1 decimeter = 10 centimeters = 3.94 inches  
 1 meter = 10 decimeters = 39.37 inches  
 1 dekameter = 10 meters = 32.8 feet  
 1 hectometer = 10 dekameters = 328.08 feet  
 1 kilometer = 10 hectometers = 3,280.8 feet

### *Weights*

1 centigram = 10 milligrams = .15 grain  
 1 decigram = 10 centigrams = 1.54 grains  
 1 gram = 10 decigrams = .035 ounce  
 1 dekagram = 10 grams = .35 ounce  
 1 hectogram = 10 dekagrams = 3.52 ounces  
 1 kilogram = 10 hectograms = 2.2 pounds  
 1 quintal = 100 kilograms = 220.46 pounds  
 1 metric ton = 10 quintals = 1.1 short tons

### *Liquid Measure*

1 centiliter = 10 milliliters = .34 fl. ounce  
 1 deciliter = 10 centiliters = 3.38 fl. ounces  
 1 liter = 10 deciliters = 33.81 fl. ounces  
 1 dekaliter = 10 liters = 2.64 gallons  
 1 hectoliter = 10 dekaliters = 26.42 gallons  
 1 kiloliter = 10 hectoliters = 264.18 gallons

### *Square Measure*

1 sq. centimeter = 100 sq. millimeters = .155 sq. inch  
 1 sq. decimeter = 100 sq. centimeters = 15.5 sq. inches  
 1 sq. meter (centare) = 100 sq. decimeters = 10.76 sq. feet  
 1 sq. dekameter (are) = 100 sq. meters = 1,076.4 sq. feet  
 1 sq. hectometer (hectare) = 100 sq. dekameters = 2.47 acres  
 1 sq. kilometer = 100 sq. hectometers = .386 sq. mile

### *Cubic Measure*

1 cu. centimeter = 1000 cu. millimeters = .06 cu. inch  
 1 cu. decimeter = 1000 cu. centimeters = 61.02 cu. inches  
 1 cu. meter = 1000 cu. decimeters = 35.31 feet

## Approximate Conversion Factors

<i>To change</i>	<i>To</i>	<i>Multiply by</i>	<i>To change</i>	<i>To</i>	<i>Multiply by</i>
inches	centimeters	2.540	ounce-inches	newton-meters	.007062
feet	meters	.305	centimeters	inches	.394
yards	meters	.914	meters	feet	3.280
miles	kilometers	1.609	meters	yards	1.094
square inches	square centimeters	6.451	kilometers	miles	.621
square feet	square meters	.093	square centimeters	square inches	.155
square yards	square meters	.836	square meters	square feet	10.764
square miles	square kilometers	2.590	square meters	square yards	1.196
acres	square hectometers	.405	square kilometers	square miles	.386
cubic feet	cubic meters	.028	square hectometers	acres	2.471
cubic yards	cubic meters	.765	cubic meters	cubic feet	35.315
fluid ounces	milliliters	29.573	cubic meters	cubic yards	1.308
pints	liters	.473	milliliters	fluid ounces	.034
quarts	liters	.946	liters	pints	2.113
gallons	liters	3.785	liters	quarts	1.057
ounces	grams	28.349	liters	gallons	.264
pounds	kilograms	.454	grams	ounces	.035
short tons	metric tons	.907	kilograms	pounds	2.205
pound-feet	newton-meters	1.356	metric tons	short tons	1.102
pound-inches	newton-meters	.11296			

## Temperature (Exact)

°F	Fahrenheit temperature	5/9 (after subtracting 32)	Celsius temperature	°C
----	---------------------------	-------------------------------	------------------------	----

**PIN: 074106-000**